

# **Data Mining and Knowledge Discovery**

**Part of  
Jožef Stefan IPS “ICT” Programme  
and “Statistics” Programme**

**2009 / 2010**

**Nada Lavrač**

Jožef Stefan Institute  
Ljubljana, Slovenia

# Course Outline

## I. Introduction

- Data Mining and KDD process
- DM standards, tools and visualization
- Classification of Data Mining techniques: Predictive and descriptive DM  
(Mladenić et al. Ch. 1 and 11, Kononenko & Kukar Ch. 1)

## II. Predictive DM Techniques

- Bayesian classifier (Kononenko Ch. 9.6)
- Decision Tree learning (Mitchell Ch. 3, Kononenko Ch. 9.1)
- Classification rule learning  
(Berthold book Ch. 7, Kononenko Ch. 9.2)
- Classifier Evaluation (Bramer Ch. 6)

## III. Regression

(Kononenko Ch. 9.4)

## IV. Descriptive DM

- Predictive vs. descriptive induction
- Subgroup discovery
- Association rule learning  
(Kononenko Ch. 9.3)
- Hierarchical clustering (Kononenko Ch. 12.3)

## V. Relational Data Mining

- RDM and Inductive Logic Programming (Dzeroski & Lavrac Ch. 3, Ch. 4)
- Propositionalization approaches
- Relational subgroup discovery

# Introductory seminar lecture

## X. JSI & Knowledge Technologies

### I. Introduction

- Data Mining and KDD process
- DM standards, tools and visualization
- Classification of Data Mining techniques: Predictive and descriptive DM  
(Mladenić et al. Ch. 1 and 11, Kononenko & Kukar Ch. 1)

### XX. Selected data mining techniques: Advanced subgroup discovery techniques and applications

### XXX. Recent advances: Cross-context link discovery

# Introductory seminar lecture

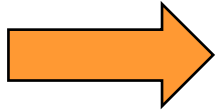

## X. JSI & Knowledge Technologies

### I. Introduction

- Data Mining and KDD process
- DM standards, tools and visualization
- Classification of Data Mining techniques: Predictive and descriptive DM

(Mladenić et al. Ch. 1 and 11, Kononenko & Kukar Ch. 1)

### XX. Selected data mining techniques: Advanced subgroup discovery techniques and applications

### XXX. Recent advances: Cross-context link discovery

# Jožef Stefan Institute - Profile

- **Jožef Stefan Institute (founded in 1949) is the leading national research organization in natural sciences and technology**
  - information and communication technologies
  - chemistry, biochemistry & nanotechnology
  - physics, nuclear technology and safety
- **Jožef Stefan International Postgraduate School (founded in 2004) offers MSc and PhD programs**
  - ICT, nanotechnology, ecotechnology
  - research oriented, basic + management courses
  - in English
- **~ 500 researchers and students**

# Department of Knowledge Technologies

- **Mission:**
  - Cutting-edge research and applications of knowledge technologies, including **data, text and web mining, machine learning, decision support, human language technologies, knowledge management**, and other information technologies that support the acquisition, management, modelling and use of knowledge and data.
- **Staff:**
  - 36 researchers and support staff + 15 students and external collaborators
- **National funding (1/3):**
  - Basic research project “Knowledge Technologies”
  - 16 National R&D projects, client applications
- **EU funding (2/3):**
  - **In FP6:**
    - 6 IP projects, 9 STREP projects, 1 FET STREP project
    - 1 Network of Excellence,
    - 4 Specific Support Actions, Coordination Actions
    - 4 bilateral projects

# Department of Knowledge Technologies

## Summary Profile

- **Machine learning & Data mining**
  - ML (decision tree and rule learning, subgroup discovery, ...)
  - Text and Web mining
  - Relational data mining - inductive logic programming
  - Equation discovery
- **Other research areas:**
  - Semantic Web and Ontologies
  - Knowledge management
  - Decision support
  - Human language technologies
- **Applications in medicine, ecological modeling, business, virtual enterprises, ...**

# Department of Knowledge Technologies

## Core application areas

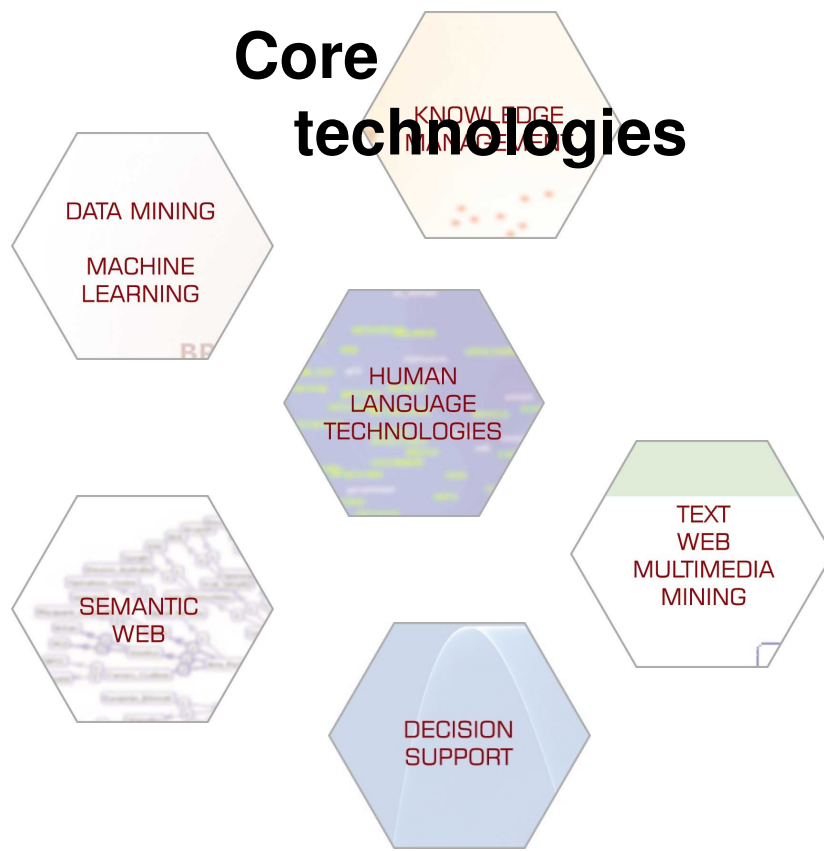

- **Medicine and Healthcare**
- **Bioinformatics**
- **Environmental studies and ecological modeling**
- **Agriculture and GMO tracking**
- **Semantic Web applications**
- **Marketing and news analysis**
- **Acquisition and management of large multilingual language corpora**
- **Digitalization of Slovene cultural heritage**



# Basic Data Mining process



**Input:** transaction data table, relational database, text documents, Web pages

**Goal:** build a classification model, find interesting patterns in data, ...

# Data Mining and Machine Learning

- Machine learning techniques
  - classification rule learning
  - subgroup discovery
  - relational data mining and ILP
  - equation discovery
  - inductive databases
- Data mining applications
  - medicine, health care
  - ecology, agriculture
  - knowledge management, virtual organizations
- Data mining and decision support integration

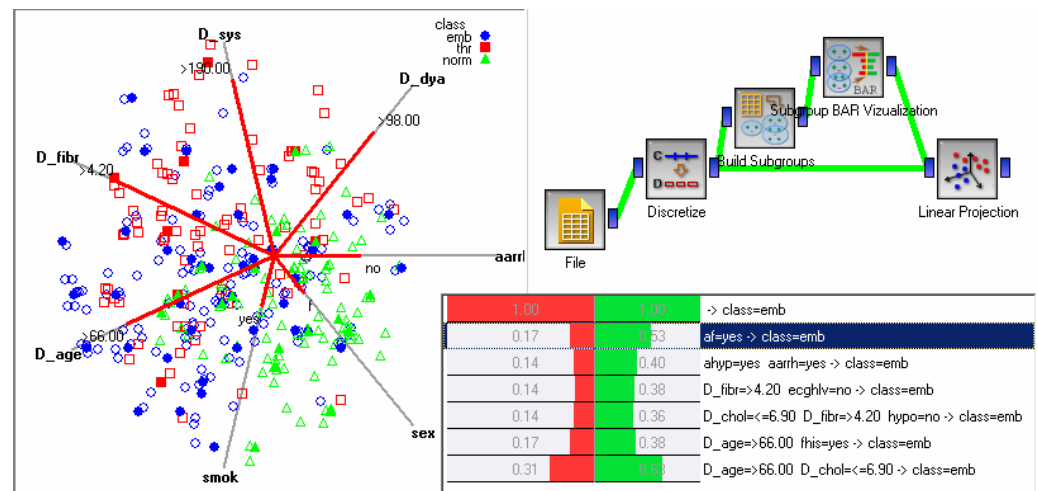

# Relational data mining: domain knowledge = relational database

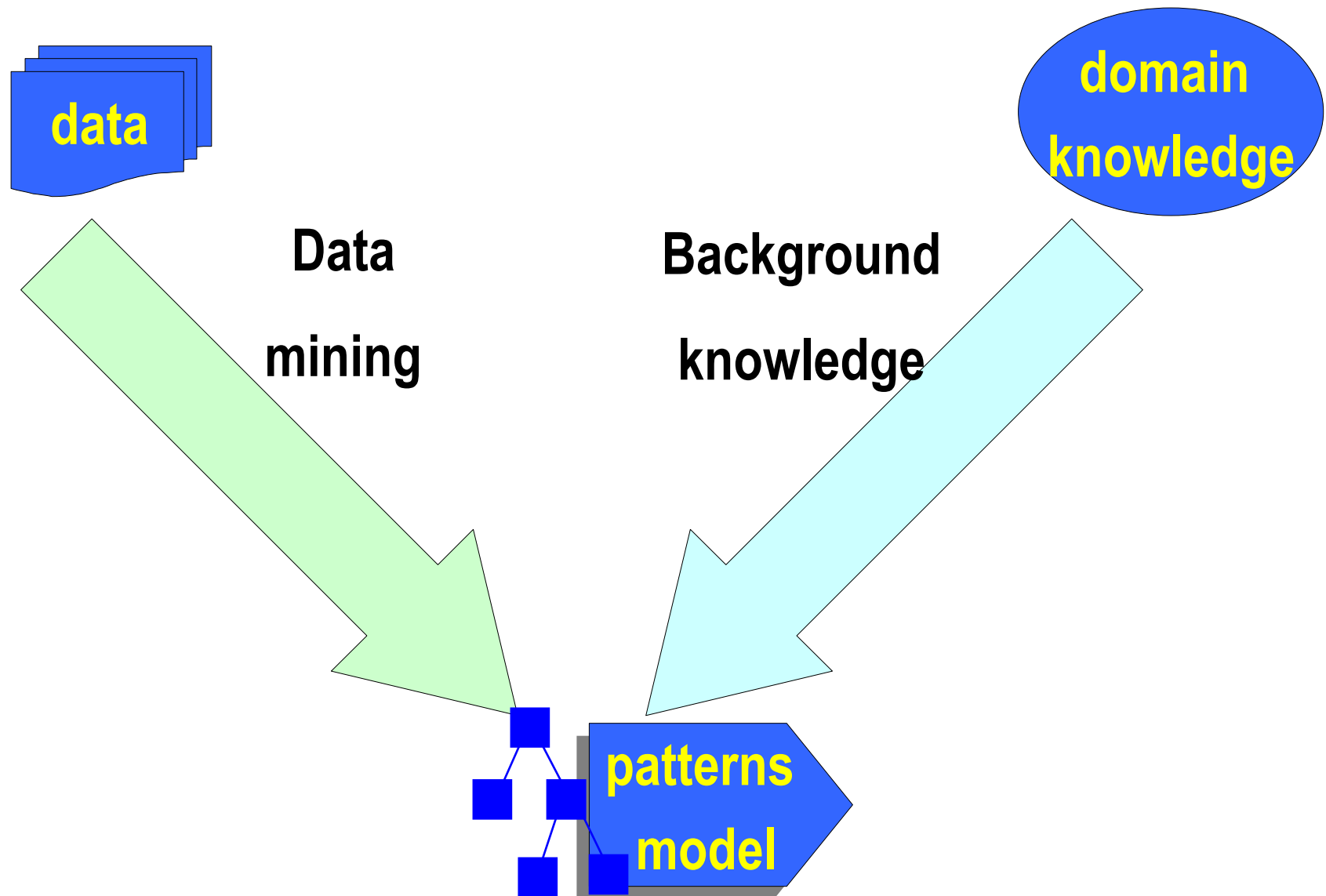

# Semantic data mining: domain knowledge = ontologies

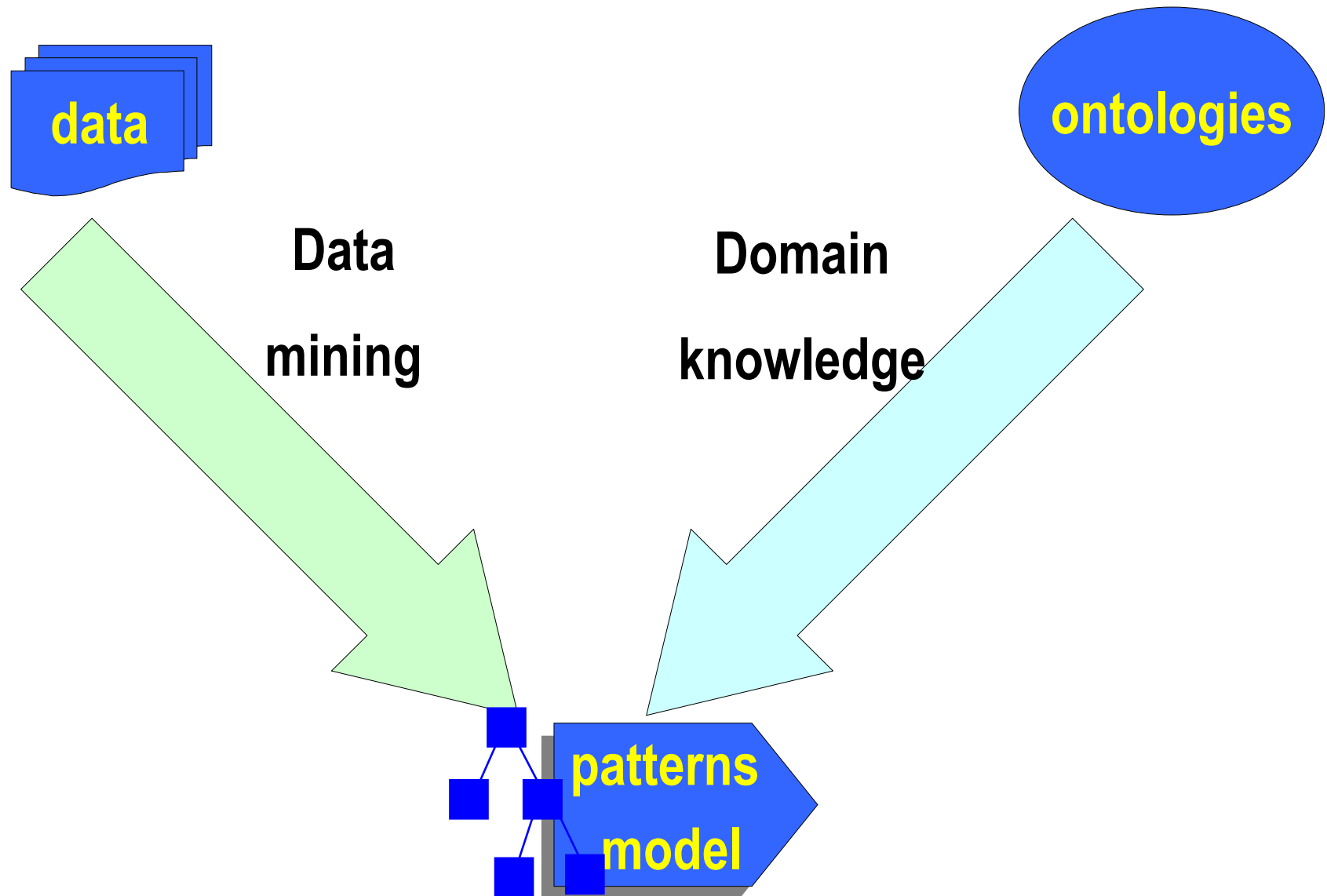

# Basic DM and DS processes



**Input:** transaction data table, relational database, text documents, Web pages

**Goal:** build a classification model, find interesting patterns in data, ...

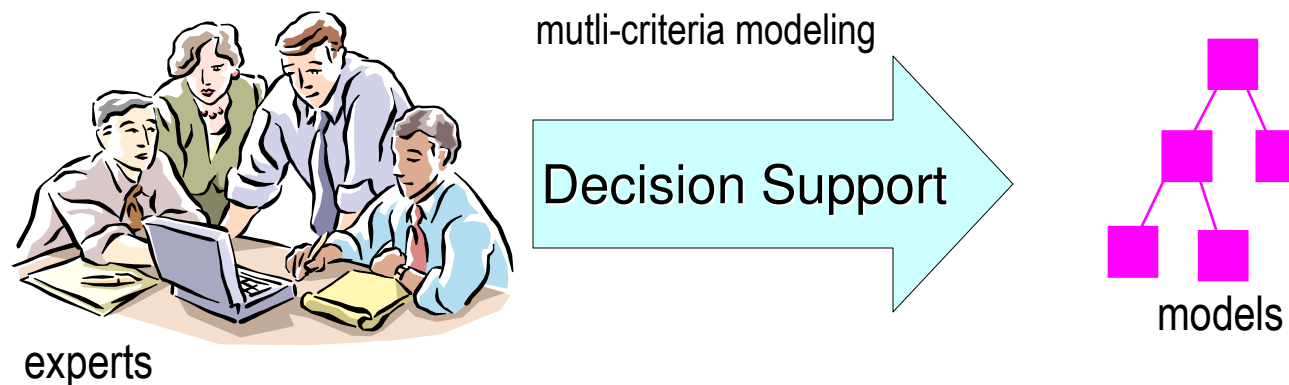

**Input:** expert knowledge about data and decision alternatives

**Goal:** construct decision support model – to support the evaluation and choice of best decision alternatives

# Decision support tools: DEXi

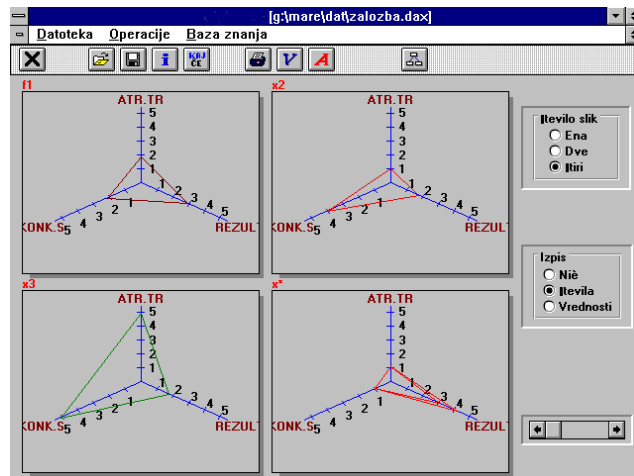
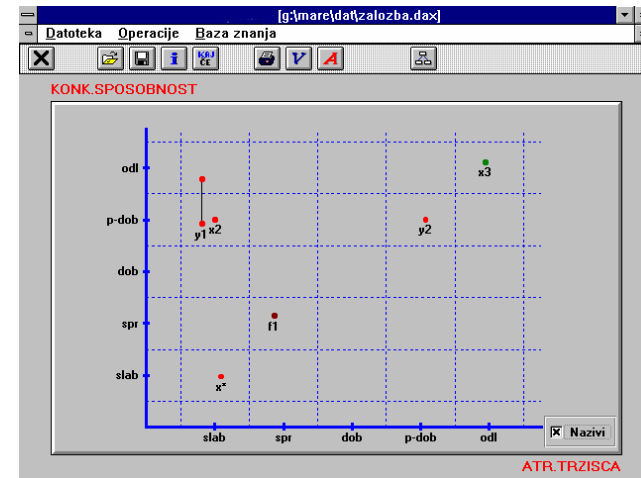
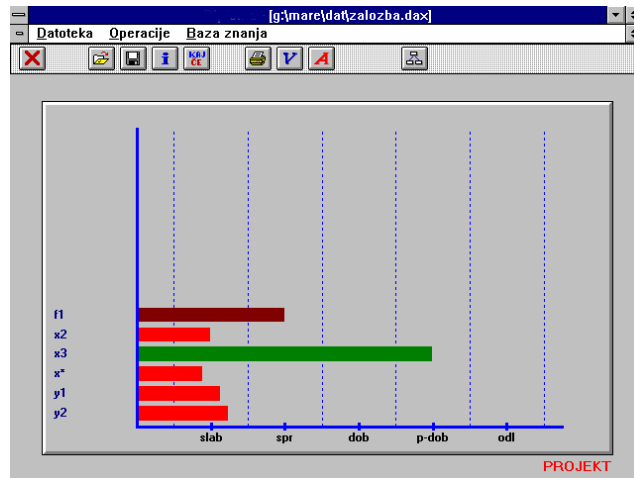

- DEXi supports :**
- *if-then analysis*
  - *analysis of stability*
  - *Time analysis*
  - *how explanation*
  - *why explanation*

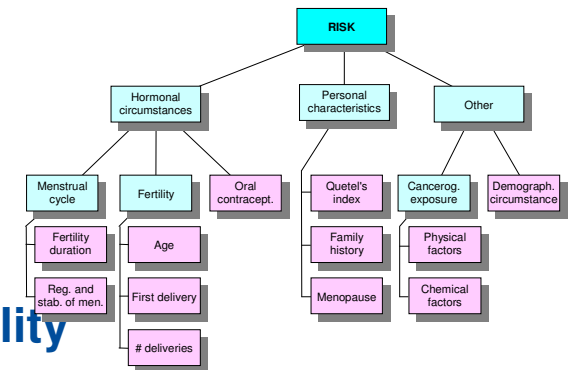

# DM and DS integration

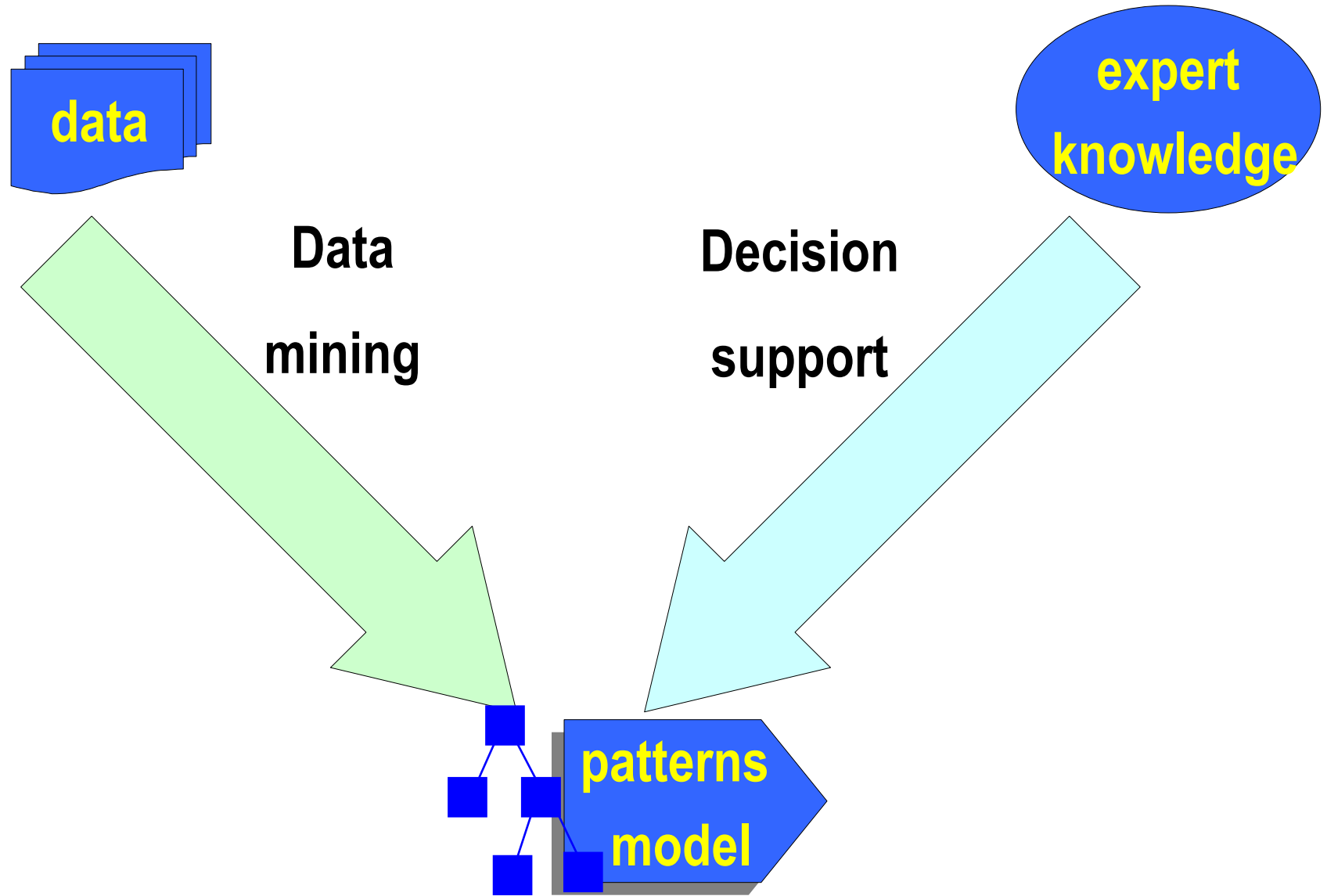

# Basic Text and Web Mining process

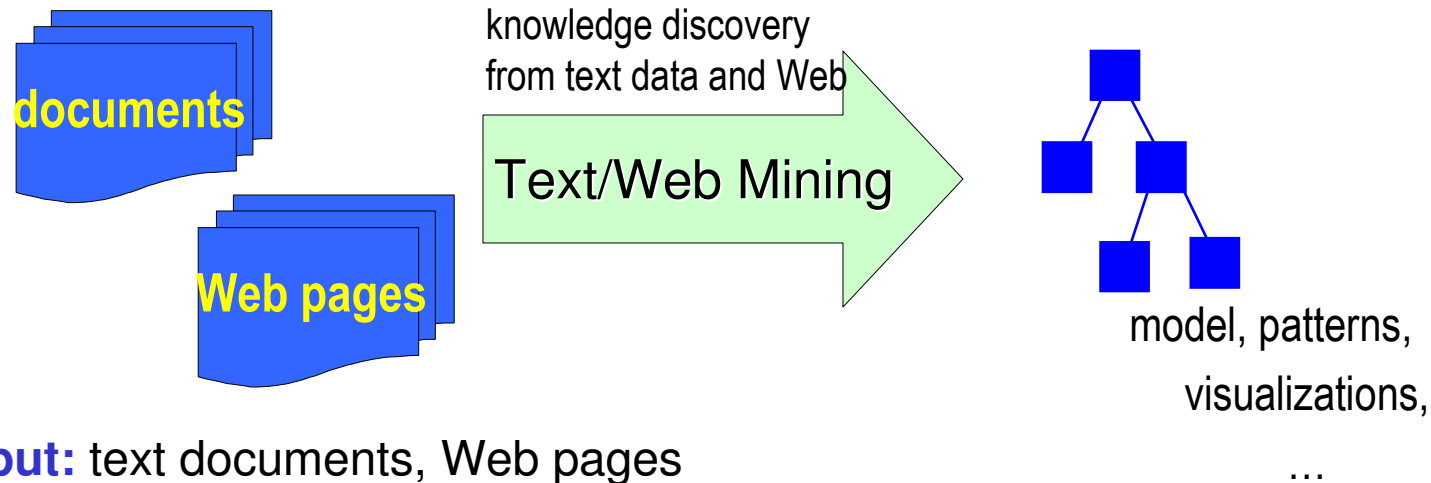

**Input:** text documents, Web pages

**Goal:** text categorization, user modeling, data visualization...



# Text Mining and Semantic Web

## Document-Atlas

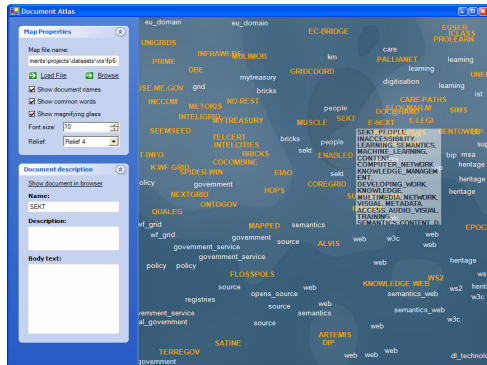

## SEKTbar

The screenshot shows the SEKTbar interface in a browser window. It features a search bar, a 'See Also' section with a list of links, and a 'User Interest Hierarchy' section. The interface is designed for navigating and exploring semantic web resources.

## Content-Land

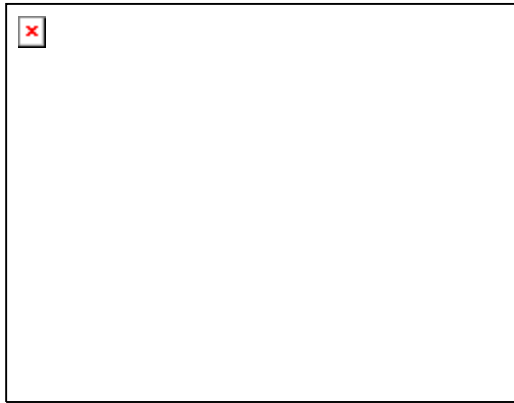
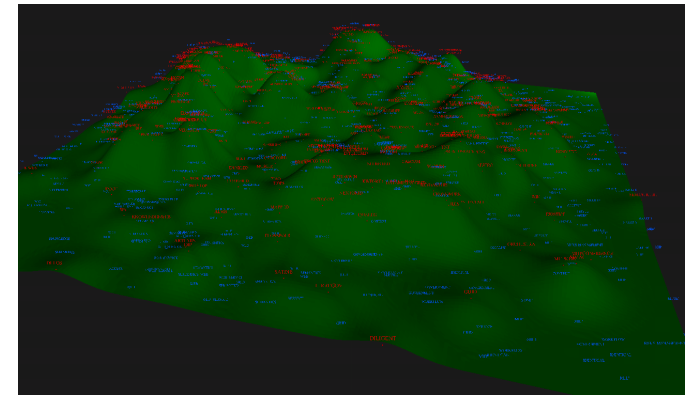

## Semantic-Graphs

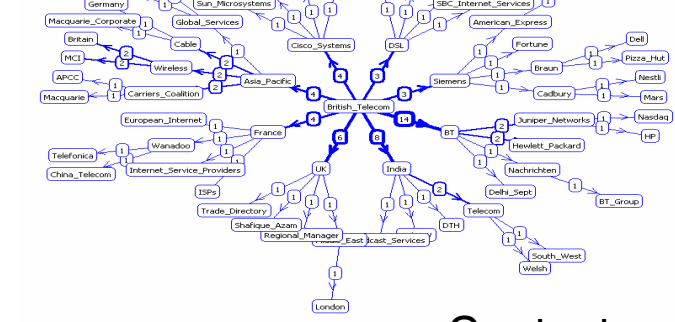
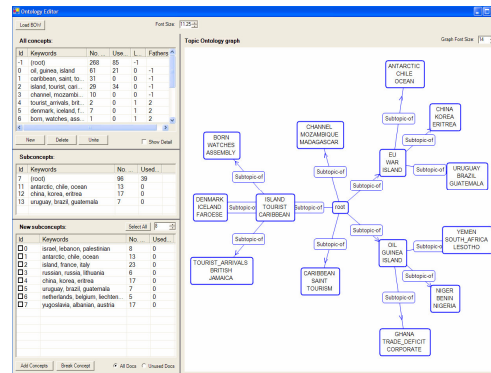

## OntoGen

## Contexter

SearchPoint jaguar

Search via topics Search via query to ontology Search via hits to ontology

(134) [Jaguar SSP - Home](#)  
 The Jaguar Species Survival Plan© promotes conservation and education related to jaguars (Panthera onca) in the wild and in zoos. It is a program of the American ...  
<http://www.jaguarssp.org/index.htm>

(6) [Jaguar \(Panthera onca\) - Wikipedia](#)  
 Article about the Jaguar, the New World mammal of the Felidae family and one of four "big cats" in the Panthera genus.  
<http://en.wikipedia.org/wiki/Jaguar>

(5) [Jaguar \(Panthera onca\)](#)  
 Provides information on the Jaguar, the largest cat of the Americas. Covers the Jaguar's physical features, behavior, habitat, distribution, and population status.  
<http://lynx.uio.no/lynx/catsgportal/cat-website/catfolk/onca-01.htm>

(75) [jaguar: Definition from Answers.com](#)  
 jaguar n. A large feline mammal (Panthera onca) of Central and South America, closely related to the leopard and having a tawny coat spotted with ...  
<http://www.answers.com/topic/jaguar>

(68) [Jaguar - Panthera onca - Defenders of Wildlife](#)  
 According to one Indian myth, the jaguar acquired its spotted coat by daubing ... Visit Defenders' Imperiled Species: Jaguar pages for more information about what ...  
[http://www.defenders.org/wildlife\\_and\\_habitat/wildlife/jaguar.php](http://www.defenders.org/wildlife_and_habitat/wildlife/jaguar.php)

(82) [Autobahn Jaguar \(Fort Worth, TX\)](#)  
 Autobahn Jaguar DFW Area. Several Jaguars currently on sale. New XK is here. Jaguar in DFW.  
<http://www.shopautobahnjaguar.com/>

(72) [Canadian XK Jaguar Register/Canadian Classic MG Club](#)  
 Jaguar MG Car Club page dealing with racing and slalom and concours events ... The Canadian XK Jaguar Register Canadian Classic MG Club is in existence to ...  
<http://jaguarmg.com/index.html>

Diagram nodes: SITE, HOTEL, PART, RUG, MUSIC, CARS, HOUSTON, DEALER, JAGUARS, DEALERSHIP

Hits promoted to this topic  
 "... MONTELEONE CARS"

# Selected Publications

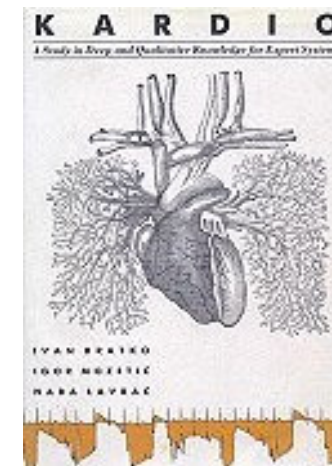
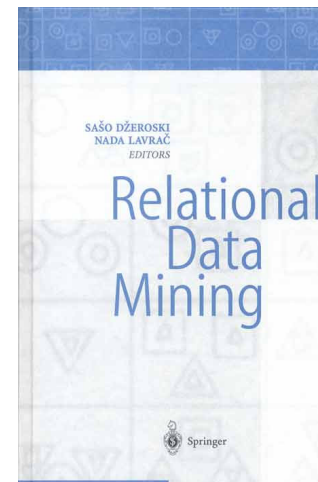
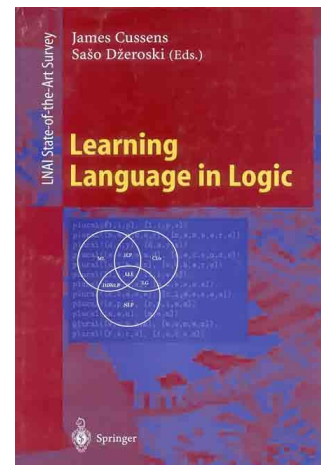
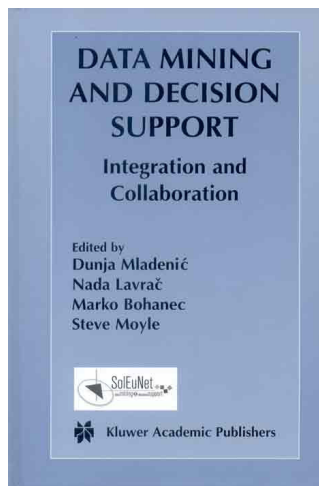
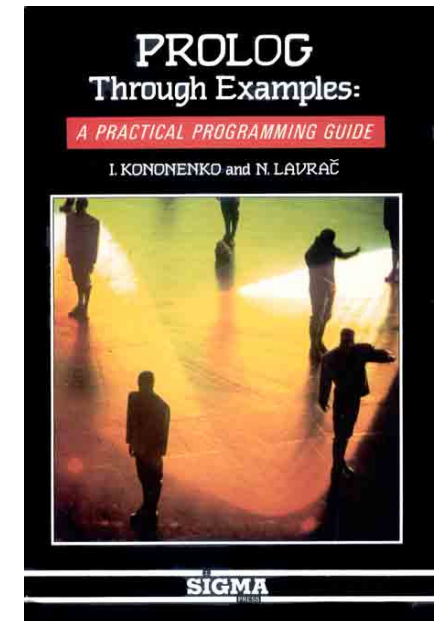
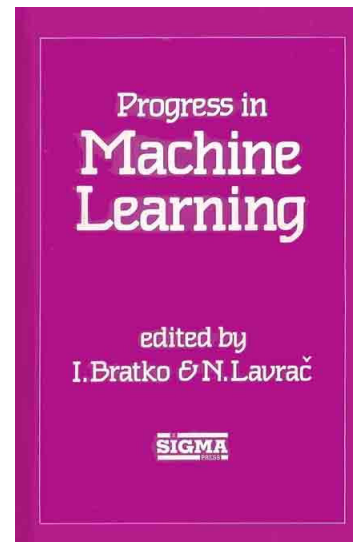
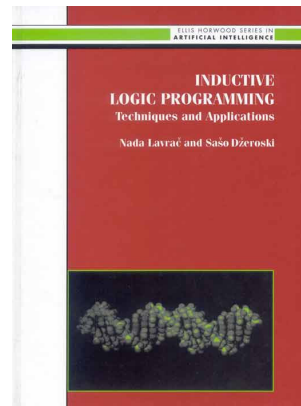
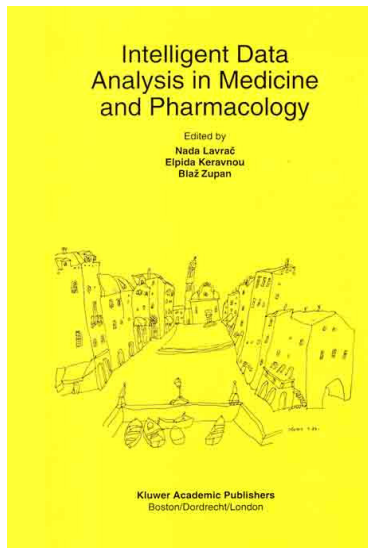





Prijava | Registracija | 

**VIDEOLECTURES.net**  
EXCHANGE IDEAS / SHARE KNOWLEDGE

242 events, 3706 authors, 4700 lectures, 5758 videos

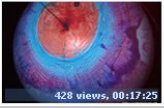
DOMOV | PRILJUBLJENO | NOVOSTI | KATEGORIJE | DOGODKI | LJUDJE | INTERVJUJI | TEČAJI | ABOUT US

**PRIPOROČENA PREDAVANJA:**

 428 views, 00:17:25 Complex Systems Art Performance Volkhard Stürzbecher 2 comments	 239 views, 01:45:49 Information extraction Ronen Feldman	 192 views, 00:22:40 Practical Guide to Controlled Experiments on the Web: Listen to Your Customers not to the HIPPO Ron Kohavi 1 comment	 [sign] 91 views, 00:48:05 Estimation of gradients and coordinate covariation in classification Sayan Mukherjee	 22 views, 00:29:51 Lessons Learned in the Challenge: Making Predictions and Scoring Them Jukka Suomela
---	---	--	---	--

**ZADNJI DOGODKI** [več](#)

**NOVICE:**

**SOCIUS - Ljubljana**  
Business Club Socius / Poslovni klub Socius  
Business Club Socius was established in 1994, under the patronage of the company Socius, whose main mission is to advise ...

**ISWC '08 - Karlsruhe**  
7th International Semantic Web Conference  
ISWC is a major international forum where visionary and state-of-the-art research of all aspects of the Semantic Web are presented. ...

**18.085 Computational Science and Engineering I**  
MIT 18.085 Computational Science and Engineering I - Fall 2007  
This course provides a review of linear algebra, including applications to networks, structures, and estimation, Lagrange multipliers. Also covered are: ...

**ESTC '08 - Vienna**  
ESTC2008  
2nd European Semantic Technology Conference

**MIT OpenCourseWare Collection**  
**MITOPENCOURSEWARE**  
MASSACHUSETTS INSTITUTE OF TECHNOLOGY  
We are excited to announce that we have started a video educational collaboration with MIT OpenCourseWare. New courses will be available every week. Check them out on the MIT OCW page.

**Cambridge University Engineering Department - Machine Learning seminars**  
**UNIVERSITY OF CAMBRIDGE**  
We are very pleased to announce a collaboration with the Department of Engineering at the University of Cambridge to make Machine Learning @ CUED talks also available via VideoLectures.net.  
*more on > [http://videolectures.net/micued08\\_cambridge/](http://videolectures.net/micued08_cambridge/)*

**Carnegie Mellon Machine Learning Lunch seminar**  
**CarnegieMellon**  
We established the collaboration with Machine Learning Department at Carnegie Mellon University to make Machine Learning Lunch seminar talks also available via VideoLectures.net.  
*more on > <http://videolectures.net/cmulls>*

**UPCOMING:**

**6. dnevi evropskega prava**  
- Kranjska gora, Slovenia  
Tudi letošnje jesen so od 20. do 22. novembra v Kranjski Gori potekali tradicionalni dnevi evropskega prava.

**KATEGORIJE:**

- Architecture (2)
- Arts (24)
- Biology (39)
- Business (79)
- Chemistry (12)
- Computers (16)
- Computer Science (1394)
- Economics (9)
- Education (5)
- Environment (13)
- Events (35)
- History (2)
- Humanities (4)
- Law (16)
- Mathematics (76)
- Medicine (30)
- Philosophy (7)
- Physics (26)
- Politics and Science (2)
- Psychology (24)
- Science (45)
- Society (33)
- Technology (13)

**FEATURED:** [več](#)

  
10 views, 00:37:53  
Nagovor predsednika Republike Slovenije dr. Danila Türka

**INTERVIEWS:** [več](#)

## ideolectures.net portal

- 8782 videos
- 7014 lectures
- 5548 authors
- 352 events
- 6118 registered users



<http://videolectures.net>

# Knowledge Technologies context of Data Mining course

Knowledge technologies are advanced information technologies, enabling

- acquisition
- storage
- modeling
- management

of large amounts of data and knowledge

Main emphasis of Department of Knowledge technologies research:  
developing knowledge technologies techniques and applications,  
aimed at dealing with information flood of heterogeneous data  
sources in solving hard decision making problems

Main emphasis of this Data Mining course:

presentation of data mining techniques that enable automated  
model construction through knowledge extraction from tabular data

# Knowledge Technologies: Main research areas & IPS lectures

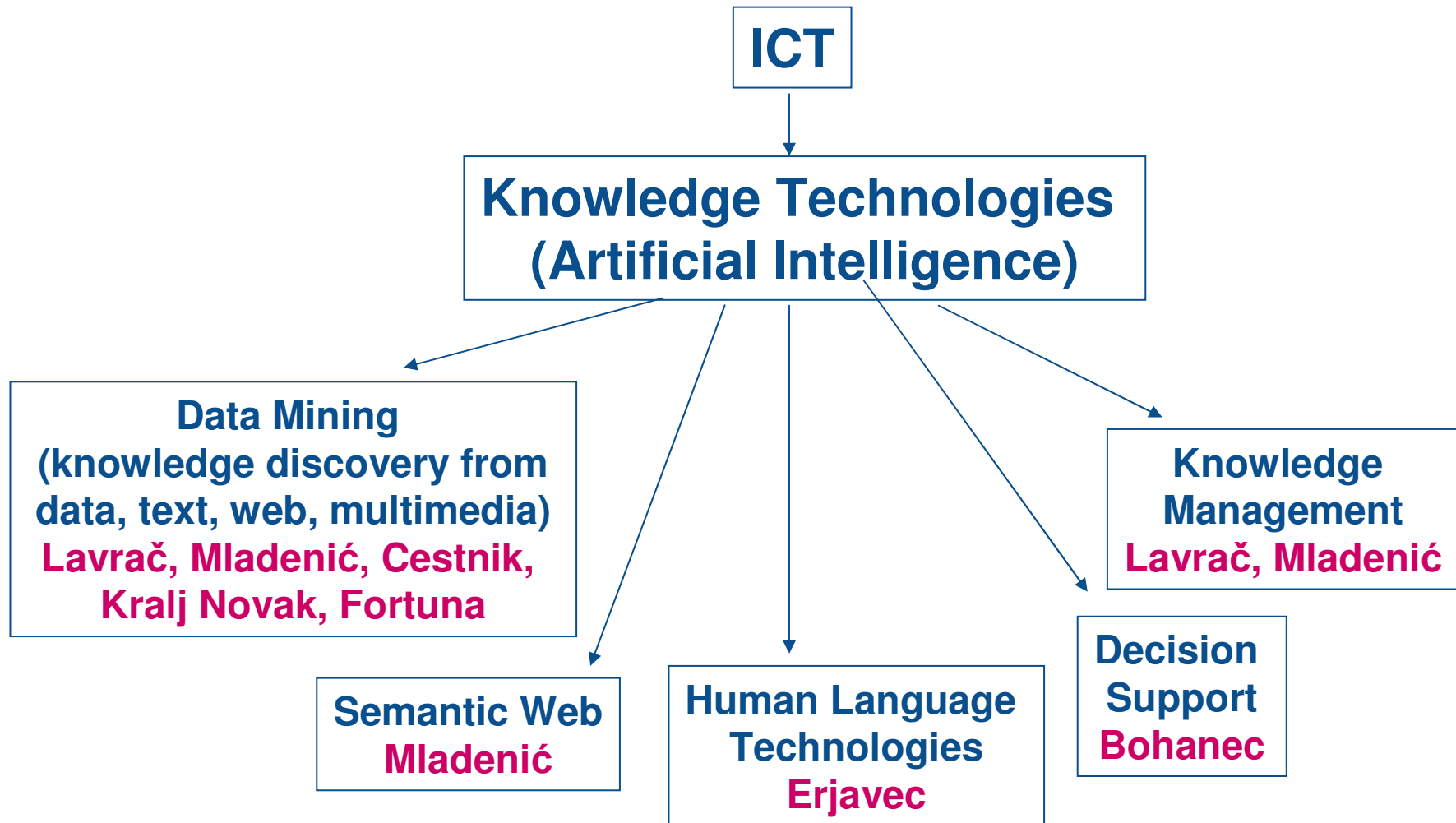

# Introductory seminar lecture

## X. JSI & Knowledge Technologies

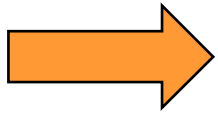

### I. Introduction

- Data Mining and KDD process
- DM standards, tools and visualization
- Classification of Data Mining techniques: Predictive and descriptive DM  
(Mladenić et al. Ch. 1 and 11, Kononenko & Kukar Ch. 1)

### XX. Selected data mining techniques: Advanced subgroup discovery techniques and applications

### XXX. Recent advances: Cross-context link discovery

# Part I. Introduction

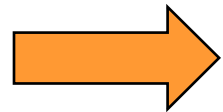

- Data Mining and the KDD process
- DM standards, tools and visualization
  - Classification of Data Mining techniques:  
Predictive and descriptive DM



# What is DM

- Extraction of useful information from data: discovering relationships that have not previously been known
- The viewpoint in this course: Data Mining is the application of Machine Learning techniques to solve real-life data analysis problems

# Related areas

## Database technology and data warehouses

- efficient storage, access and manipulation of data

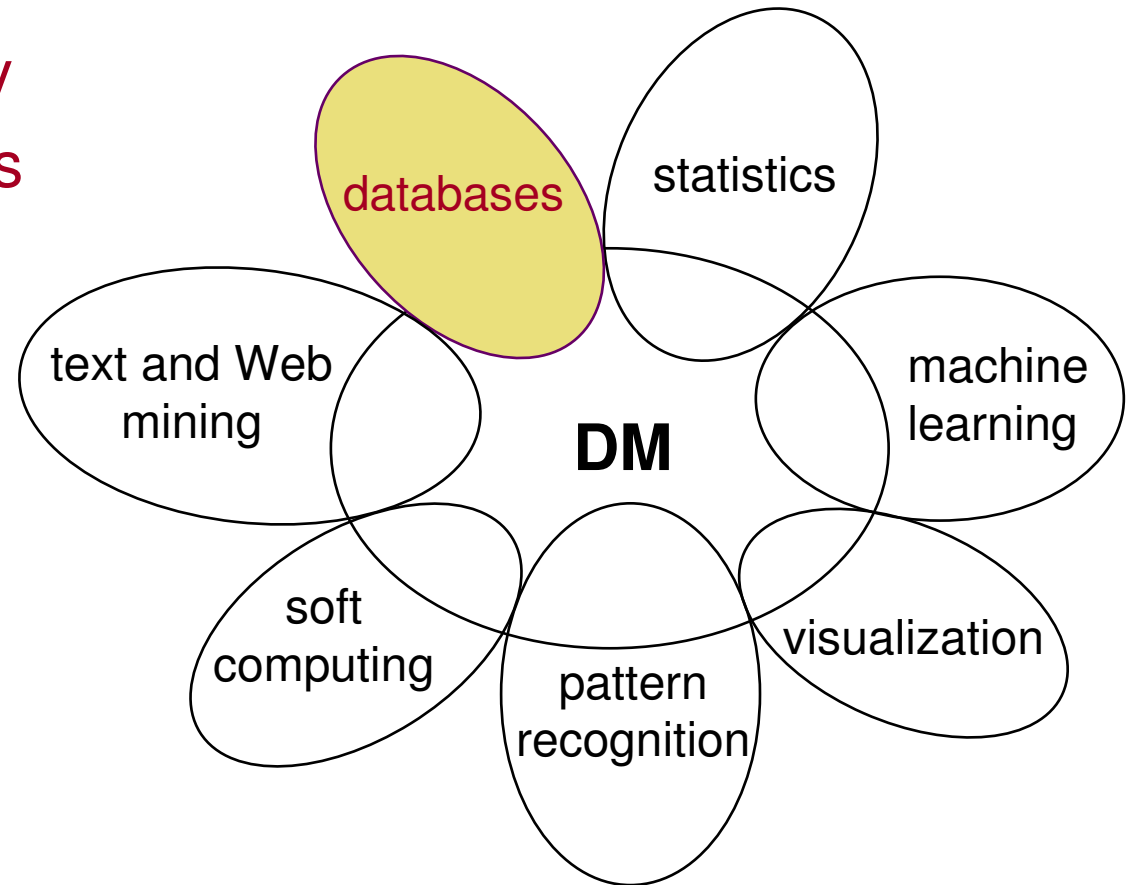

# Related areas

Statistics,  
machine learning,  
pattern recognition  
and soft computing\*

- classification techniques and techniques for knowledge extraction from data

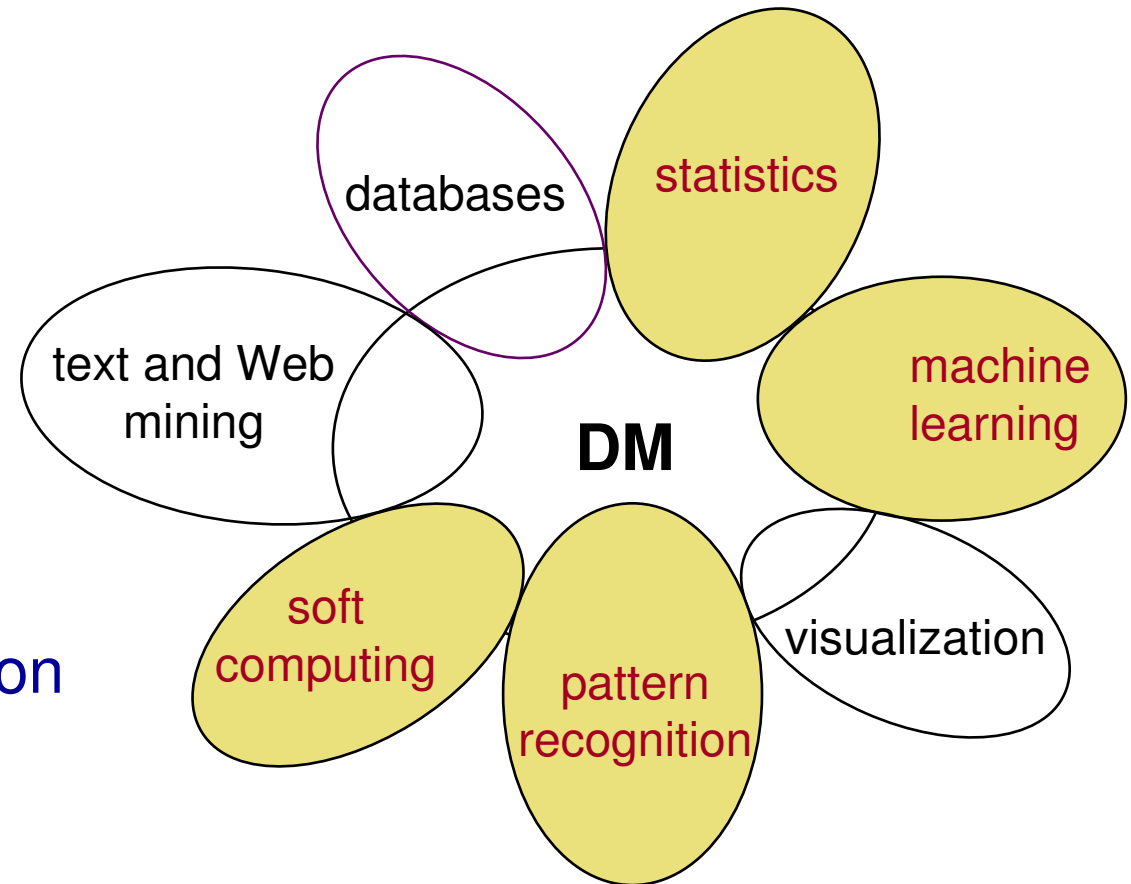

\* neural networks, fuzzy logic, genetic algorithms, probabilistic reasoning

# Related areas

## Text and Web mining

- Web page analysis
- text categorization
- acquisition, filtering and structuring of textual information
- natural language processing

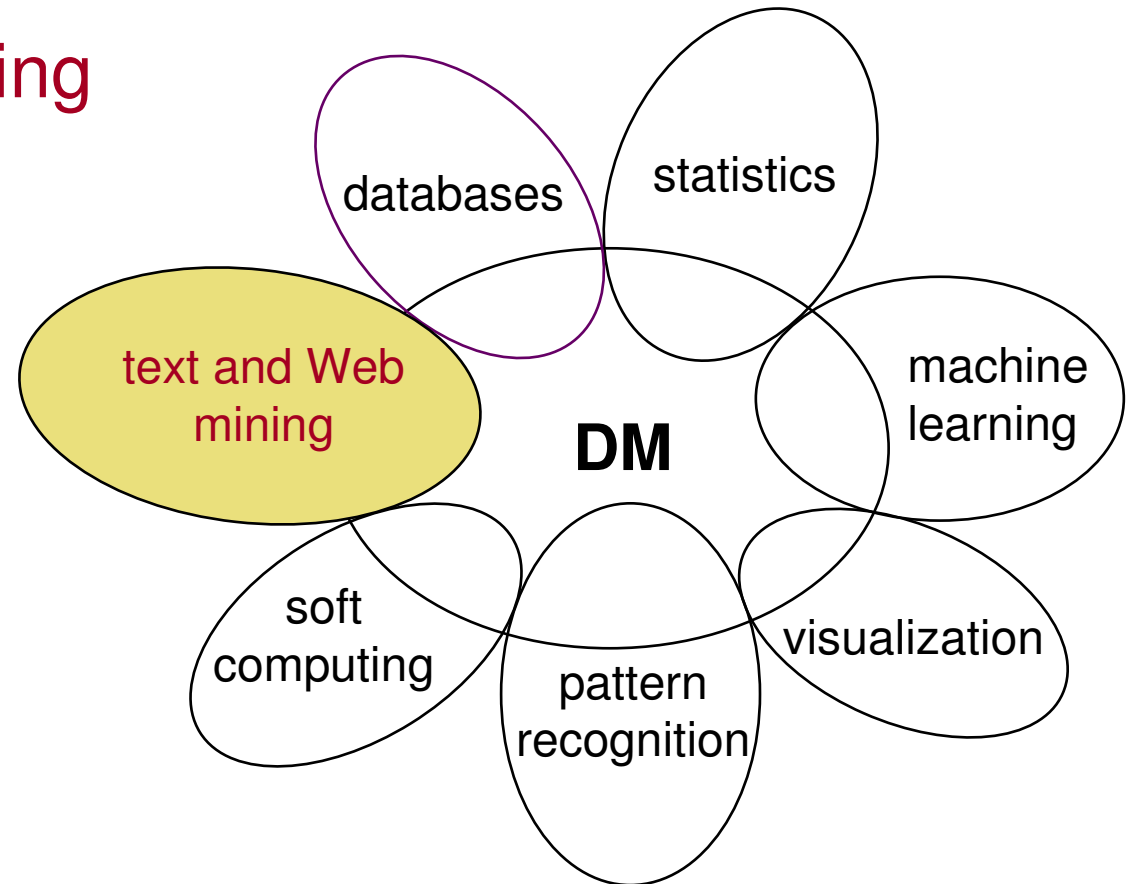

# Related areas

## Visualization

- visualization of data and discovered knowledge

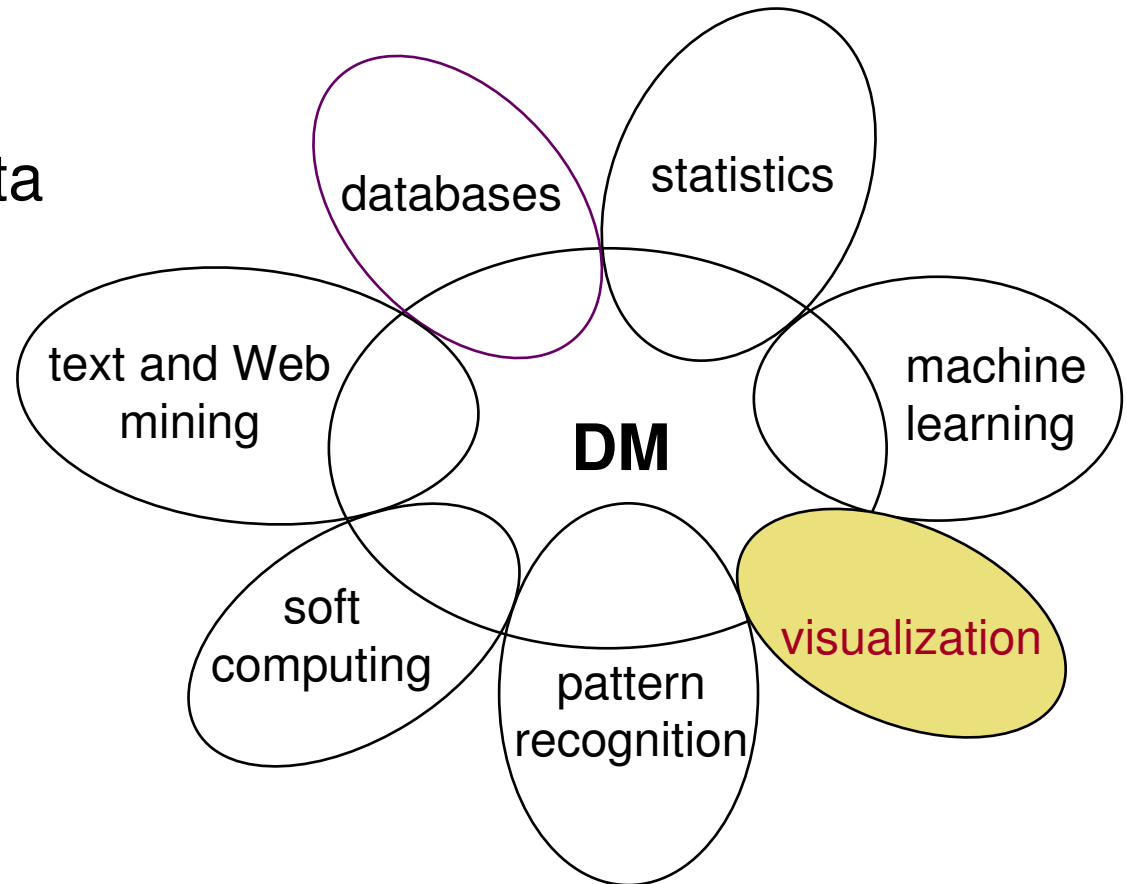

# Point of view in this course

Knowledge  
discovery using  
machine  
learning  
methods

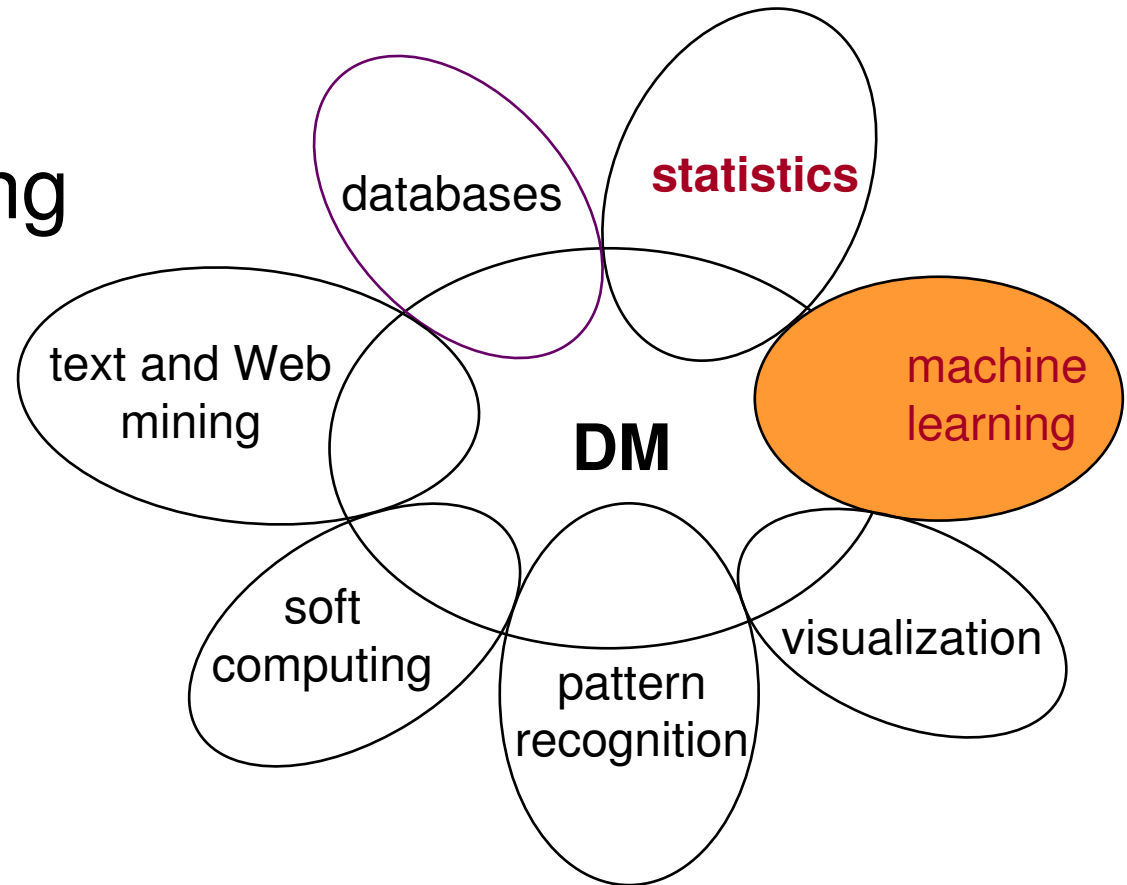

# Data Mining, ML and Statistics

- All areas have a long tradition of developing inductive techniques for data analysis.
  - reasoning from properties of a data sample to properties of a population
- DM vs. ML - Viewpoint in this course:
  - Data Mining is the application of Machine Learning techniques to hard real-life data analysis problems
- DM vs. Statistics:
  - Statistics
    - Hypothesis testing when certain theoretical expectations about the data distribution, independence, random sampling, sample size, etc. are satisfied
    - Main approach: best fitting all the available data
  - Data mining
    - Automated construction of understandable patterns, and structured models
    - Main approach: structuring the data space, heuristic search for decision trees, rules, ... covering (parts of) the data space

# Data Mining and KDD

- KDD is defined as “the process of identifying valid, novel, potentially useful and ultimately understandable models/patterns in data.” \*
- Data Mining (DM) is the key step in the KDD process, performed by using data mining techniques for extracting models or interesting patterns from the data.

*Usama M. Fayyad, Gregory Piatesky-Shapiro, Pedhraic Smyth: The KDD Process for Extracting Useful Knowledge from Volumes of Data. Comm ACM, Nov 96/Vol 39 No 11*



# KDD Process

KDD process of discovering useful knowledge from data

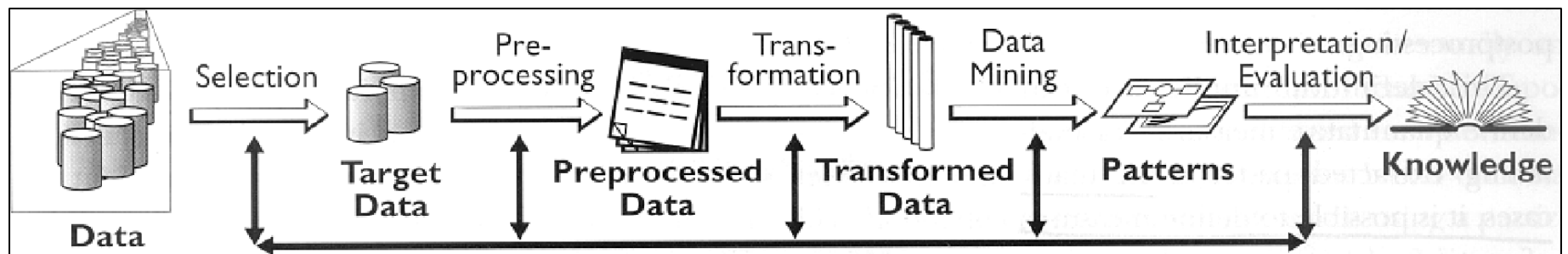

- KDD process involves several phases:
  - data preparation
  - data mining (machine learning, statistics)
  - evaluation and use of discovered patterns
- Data mining is the key step, but represents only 15%-25% of the entire KDD process

# MEDIANA – analysis of media research data

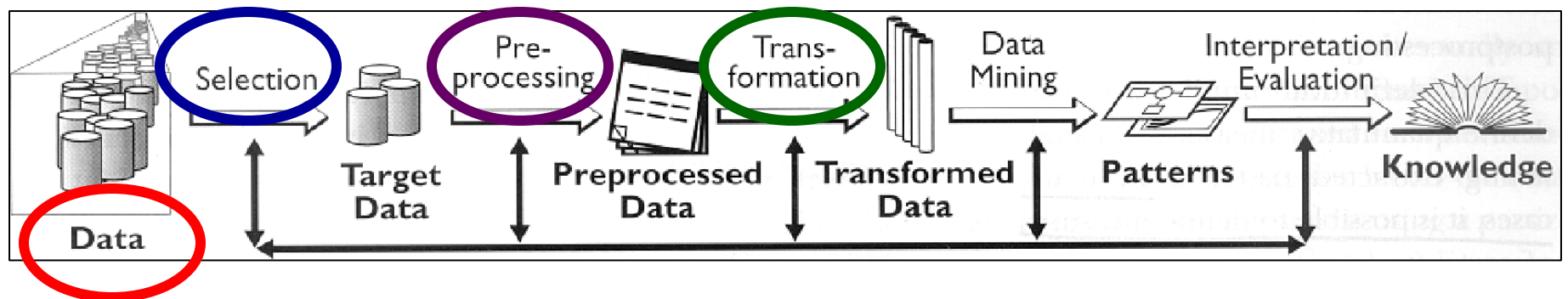

- Questionnaires about journal/magazine reading, watching of TV programs and listening of radio programs, since 1992, about 1200 questions. Yearly publication: frequency of reading/listening/watching, distribution w.r.t. Sex, Age, Education, Buying power,..
- Data for 1998, about 8000 questionnaires, covering lifestyle, spare time activities, personal viewpoints, reading/listening/watching of media (yes/no/how much), interest for specific topics in media, social status
- good quality, “clean” data
- table of n-tuples (rows: individuals, columns: attributes, in classification tasks selected class)

# MEDIANA – media research pilot study

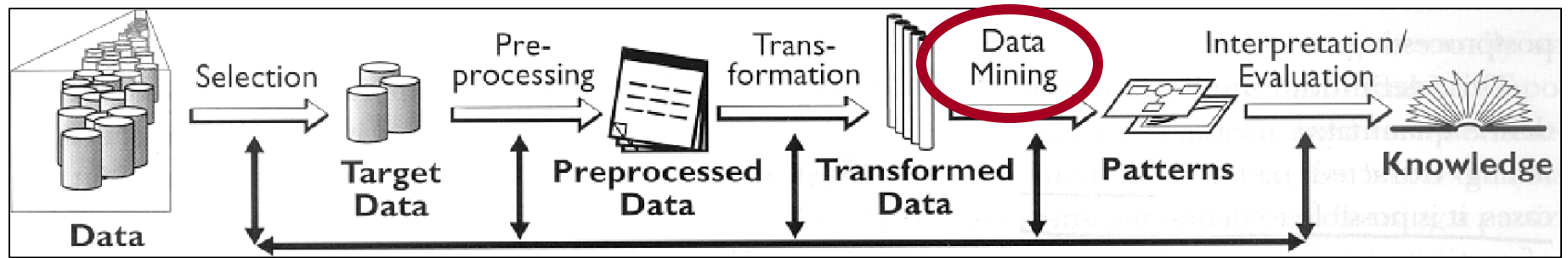

- **Patterns uncovering regularities concerning:**
  - Which other journals/magazines are read by readers of a particular journal/magazine ?
  - What are the properties of individuals that are consumers of a particular media offer ?
  - Which properties are distinctive for readers of different journals ?
- **Induced models: description (association rules, clusters) and classification (decision trees, classification rules)**

# Simplified association rules

## Finding profiles of readers of the Delo daily newspaper

1. reads\_Marketing\_magazine 116 →  
reads\_Delo 95 (0.82)
2. reads\_Financial\_News (Finance) 223 → reads\_Delo 180  
(0.81)
3. reads\_Views (Razgledi) 201 → reads\_Delo 157 (0.78)
4. reads\_Money (Denar) 197 → reads\_Delo 150 (0.76)
5. reads\_Vip 181 → reads\_Delo 134 (0.74)

**Interpretation:** Most readers of Marketing magazine, Financial News, Views, Money and Vip read also Delo.

## Simplified association rules

1. reads\_Sara 332 → reads\_Slovenske novice 211 (0.64)
2. reads\_Ljubezenske zgodbe 283 →  
reads\_Slovenske novice 174 (0.61)
3. reads\_Dolenjski list 520 →  
reads\_Slovenske novice 310 (0.6)
4. reads\_Omama 154 → reads\_Slovenske novice 90 (0.58)
5. reads\_Delavska enotnost 177 →  
reads\_Slovenske novice 102 (0.58)

Most of the readers of Sara, Love stories, Dolenjska new, Omama in Workers new read also Slovenian news.

# Simplified association rules

1. reads\_Sportske novosti 303 →  
reads\_Slovenski delnicar 164 (0.54)
2. reads\_Sportske novosti 303 →  
reads\_Salomonov oglasnik 155 (0.51)
3. reads\_Sportske novosti 303 →  
reads\_Lady 152 (0.5)

More than half of readers of Sports news reads also Slovenian shareholders magazine, Solomon advertisements and Lady.

# Decision tree

Finding reader profiles: decision tree for classifying people into readers and non-readers of a teenage magazine Antena.

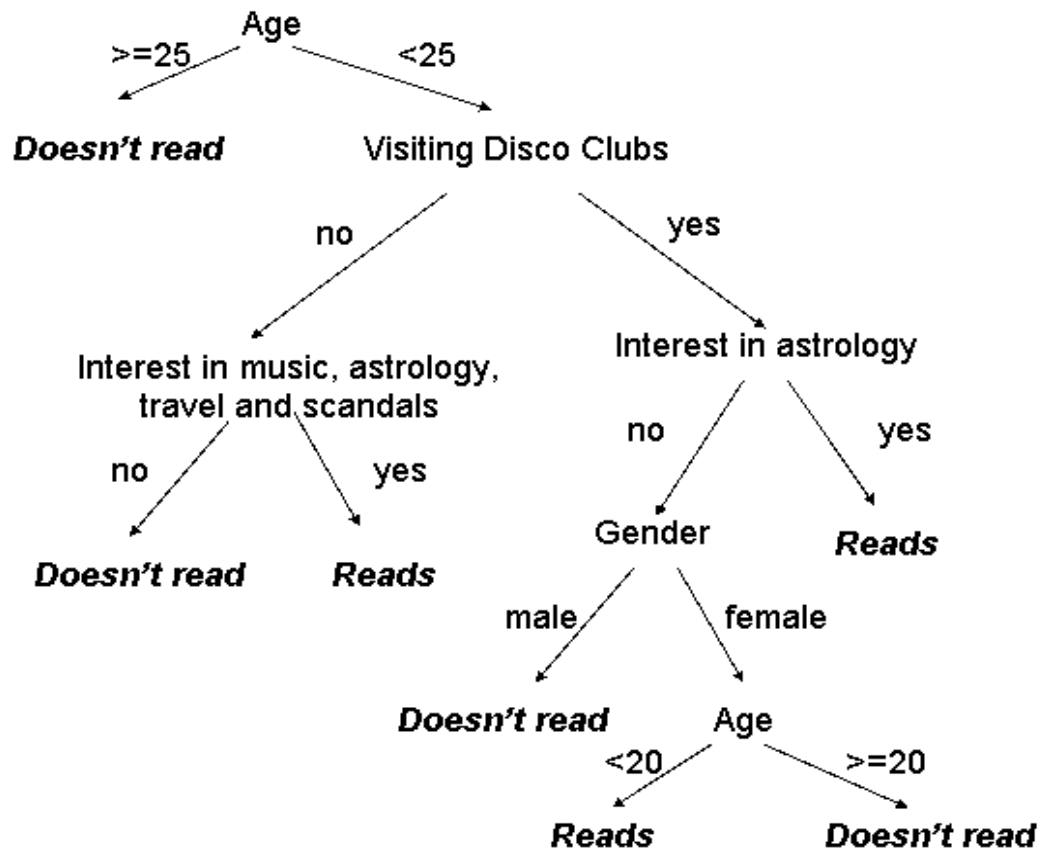

# Part I. Introduction

Data Mining and the KDD process

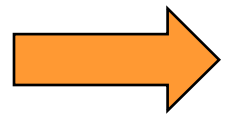

DM standards, tools and visualization

- Classification of Data Mining techniques:  
Predictive and descriptive DM



# CRISP-DM

- Cross-Industry Standard Process for DM
- A collaborative, 18-months partially EC founded project started in July 1997
- NCR, ISL (Clementine), Daimler-Benz, OHRA (Dutch health insurance companies), and SIG with more than 80 members
- **DM from art to engineering**
- Views DM more broadly than Fayyad et al. (actually DM is treated as KDD process):

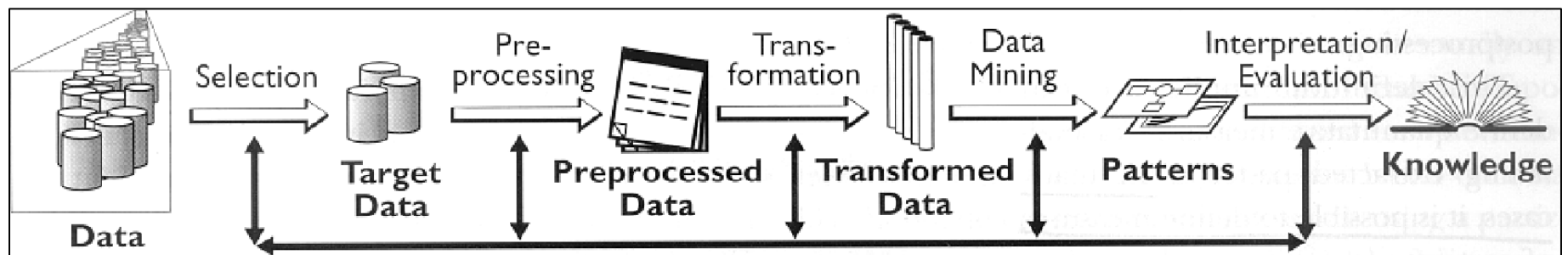

# CRISP Data Mining Process

- DM Tasks

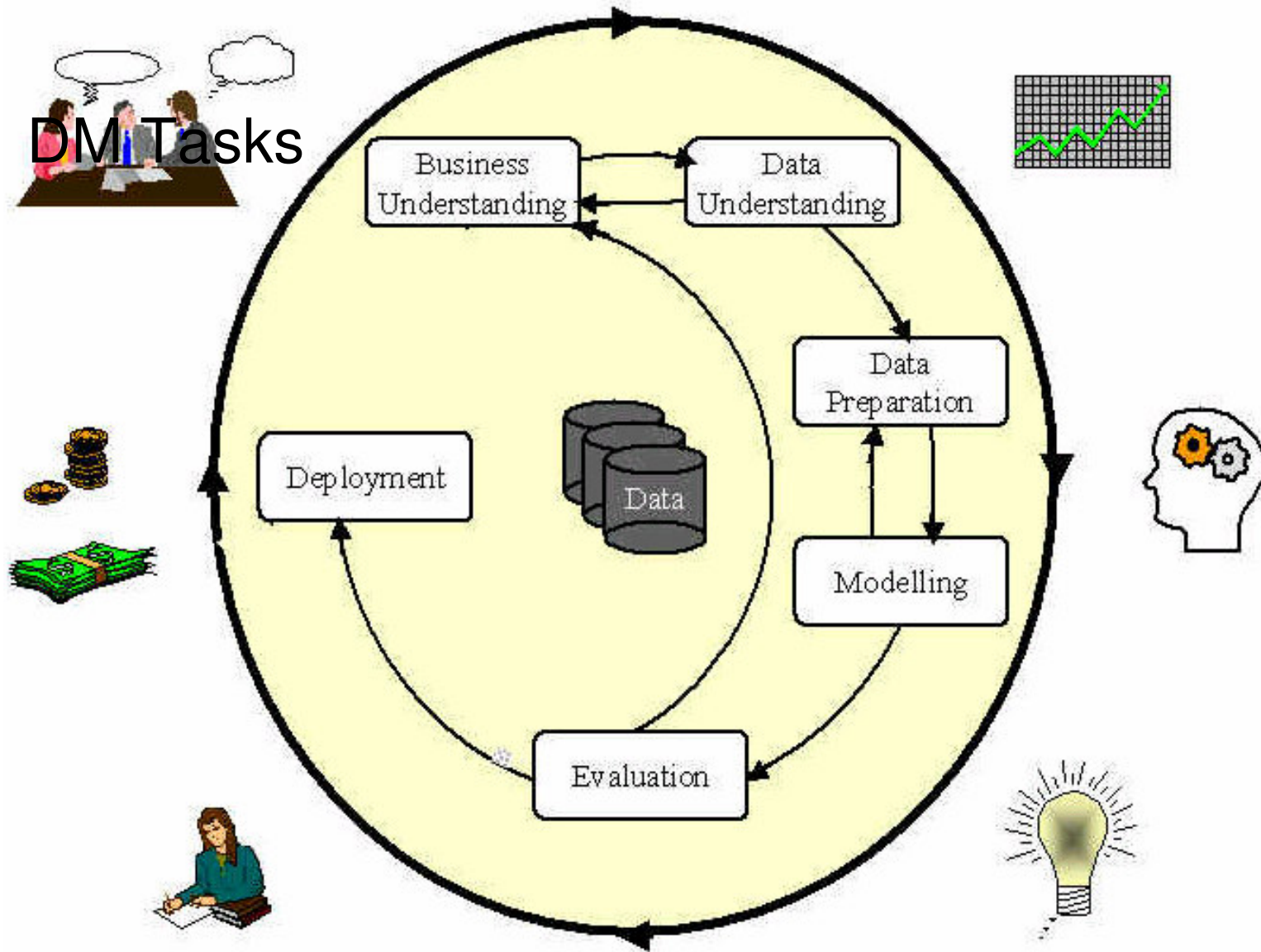

# DM tools

**KDNuggets Directory: Data Mining and Knowledge Discovery - Netscape**

File Edit View Go Communicator Help

Bookmarks Location: <http://www.kdnuggets.com/> What's Related

**KDNuggets.com** Path: [KDNuggets Home](#) :

## Tools (Software) for Data Mining and Knowledge Discovery

Email new submissions and changes to [editor@kdnuggets.com](mailto:editor@kdnuggets.com)

- [Suites](#) supporting multiple discovery tasks and data preparation
- [Classification](#) -- for building a classification model  
Approach: [Multiple](#) | [Decision tree](#) | [Rules](#) | [Neural network](#) | [Bayesian](#) | [Other](#)
- [Clustering](#) - for finding clusters or segments
- [Statistics, Estimation and Regression](#)
- [Links and Associations](#) - for finding links, dependency networks, and associations
- [Sequential Patterns](#) - tools for finding sequential patterns
- [Visualization](#) - scientific and discovery-oriented visualization
- [Text and Web Mining](#)
- [Deviation and Fraud Detection](#)
- [Reporting and Summarization](#)
- [Data Transformation and Cleaning](#)
- [OLAP and Dimensional Analysis](#)

Document: Done

# Public DM tools

- WEKA - **W**aikato **E**nvironment for **K**nowledge **A**nalysis
- Orange, Orange4WS
- KNIME - Konstanz Information Miner
- R – Bioconductor, ...

Weka Knowledge Explorer

Preprocess Classify Cluster Associate Select attributes Visualize

Open file... Open URL... Open DB... Apply Filters Replace Save...

Base relation  
Relation: weather  
Instances: 14  
Attributes: 5

Working relation  
Relation: weather  
Instances: 14  
Attributes: 5

Attributes in base relation

No.	Name
1	<input checked="" type="checkbox"/> outlook
2	<input checked="" type="checkbox"/> temperature
3	<input checked="" type="checkbox"/> humidity
4	<input checked="" type="checkbox"/> windy
5	<input checked="" type="checkbox"/> play

Attribute info for base relation

Name: humidity  
Missing: 0 (0%)  
Distinct: 10  
Type: Numeric  
Unique: 7 (50%)

Statistic	Value
Minimum	65.0
Maximum	96.0
Mean	81.64285714285714
StdDev	10.285218242007051

Log

07:31:49: email: wekasupport@cs.waikato.ac.nz  
07:31:49: Started on Torek, 6 marec 2001  
07:32:00: Base relation is now weather (14 instances)  
07:32:00: Working relation is now weather (14 instances)

Status  
OK

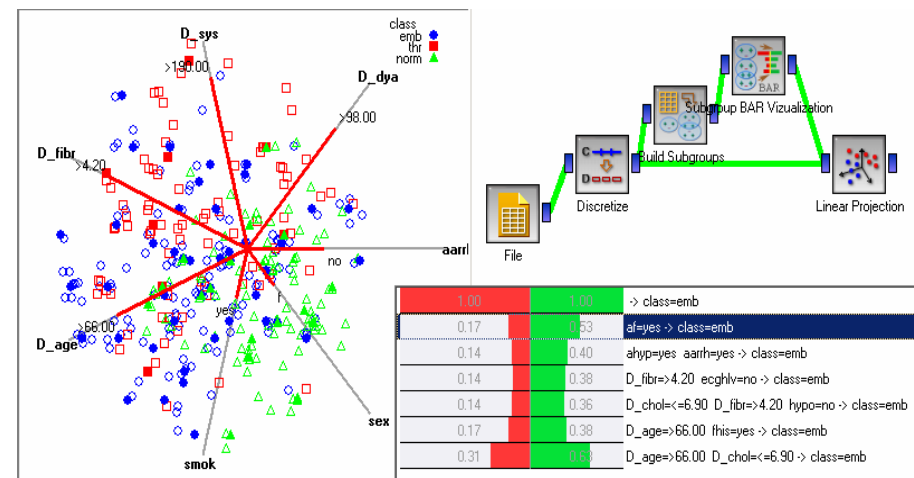

# Visualization

- can be used on its own (usually for description and summarization tasks)
- can be used in combination with other DM techniques, for example
  - visualization of decision trees
  - cluster visualization
  - visualization of association rules
  - subgroup visualization

# Data visualization: Scatter plot

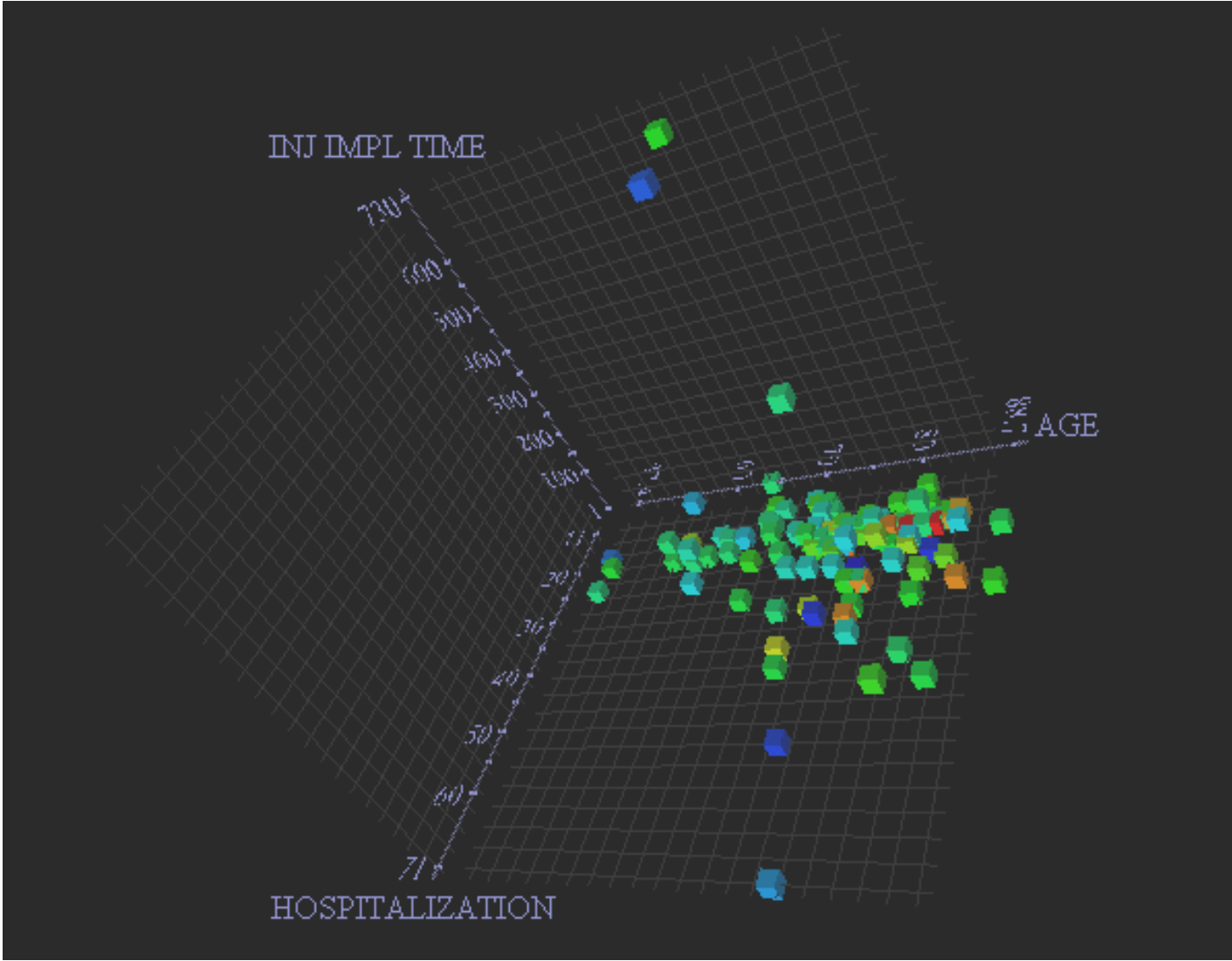

# DB Miner: Association rule visualization

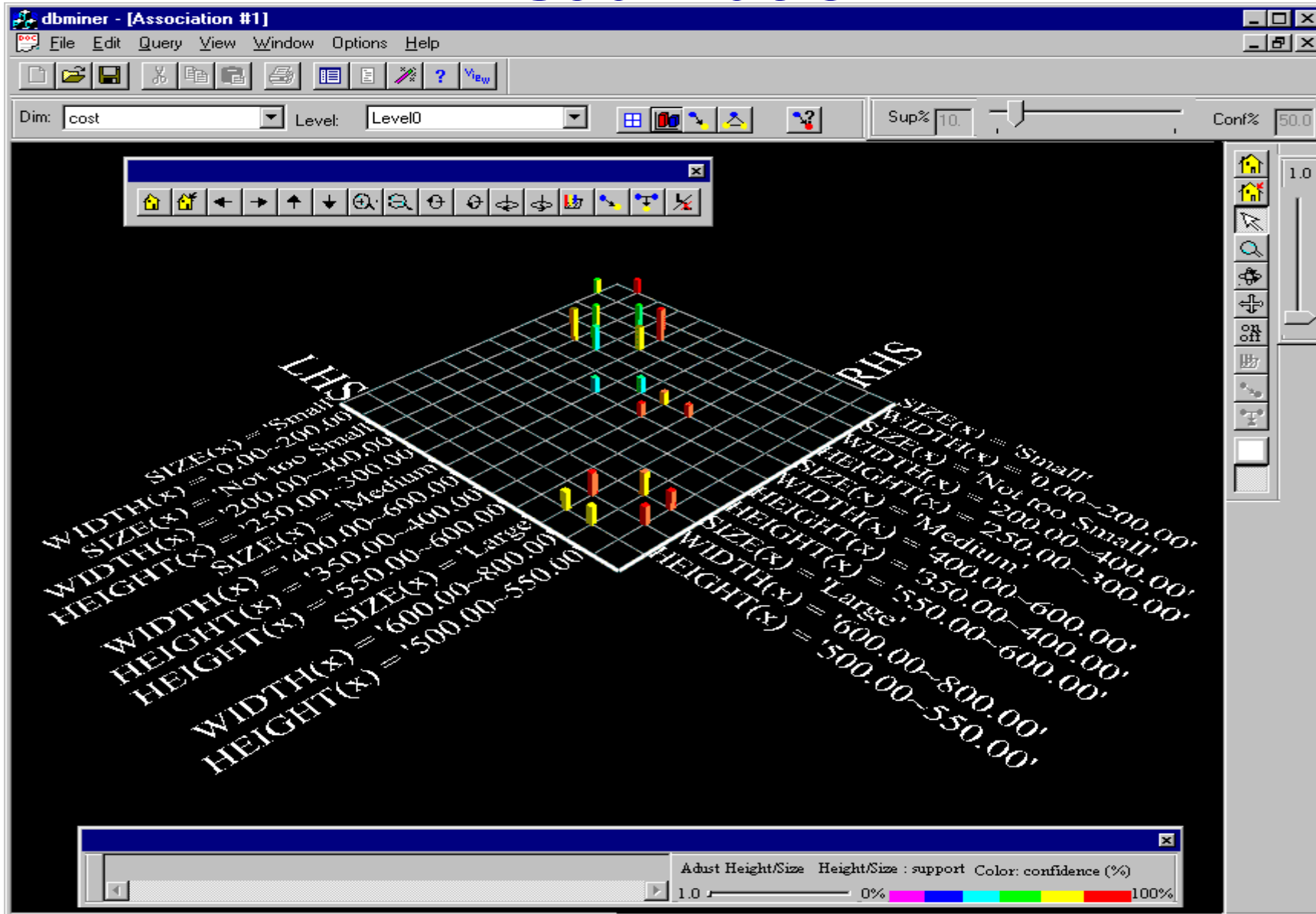

# MineSet: Decision tree visualization

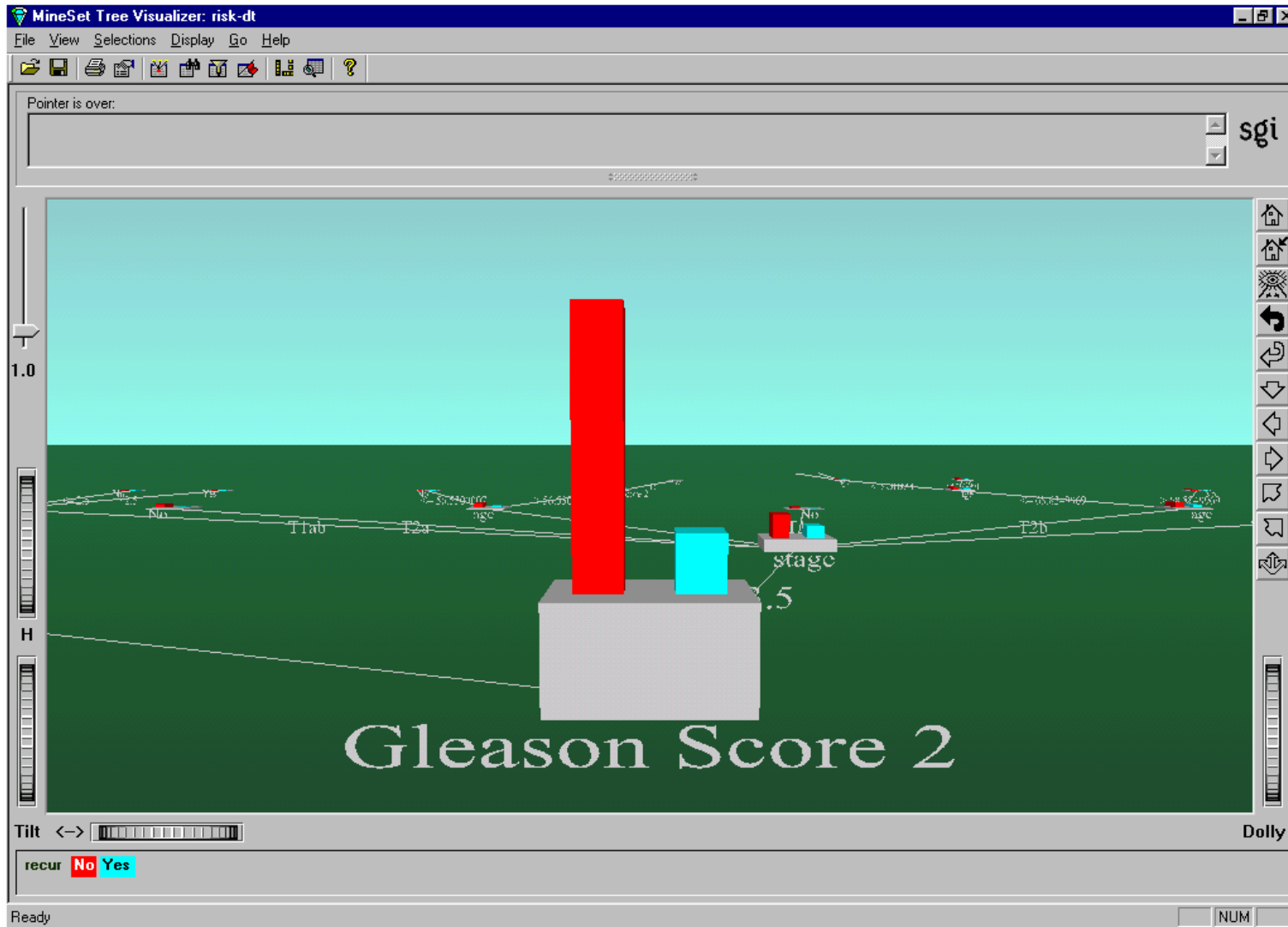



# Orange: Visual programming and subgroup discovery visualization

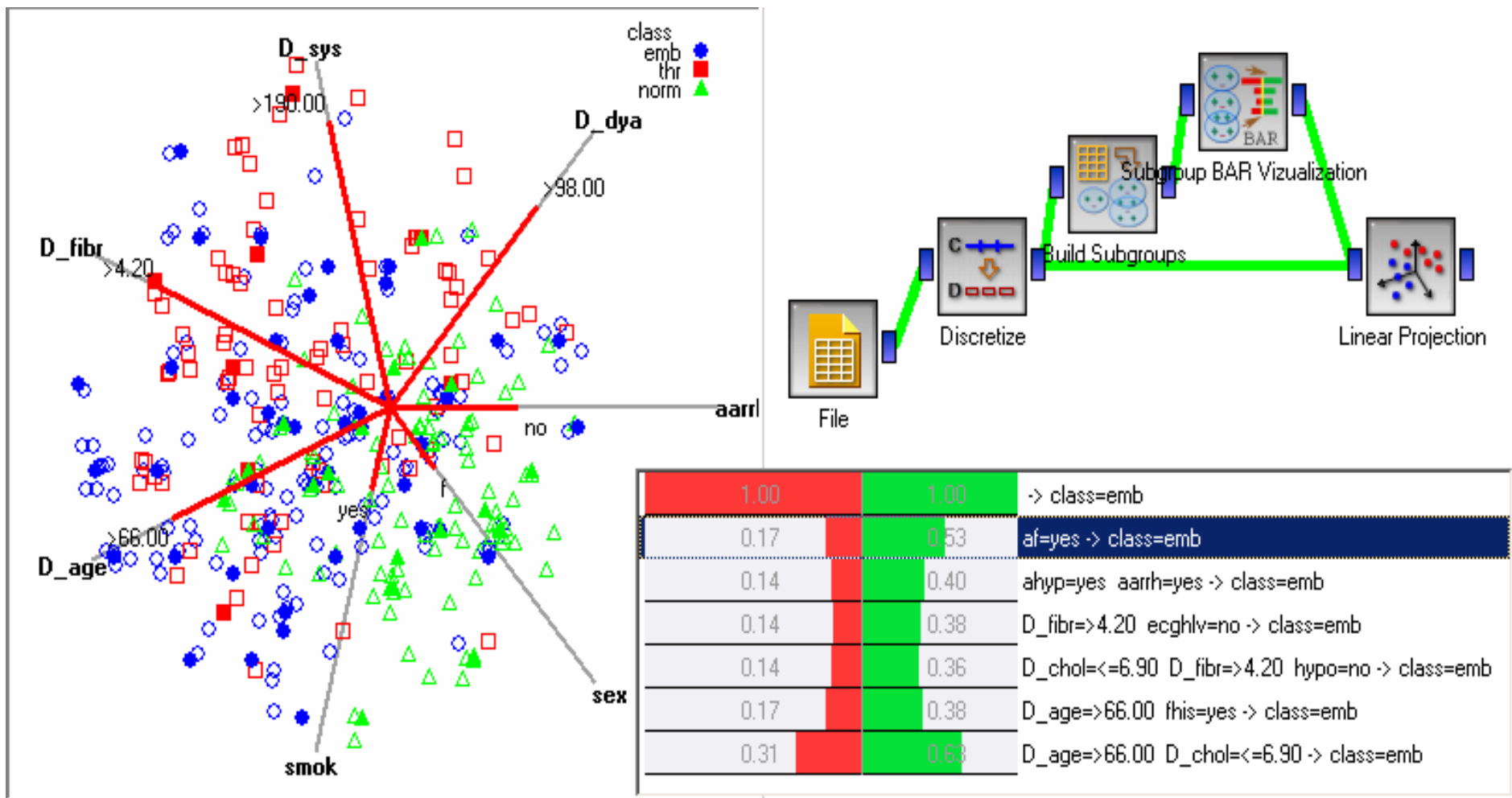

# Part I. Introduction

Data Mining and the KDD process

- DM standards, tools and visualization

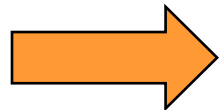

Classification of Data Mining techniques:  
Predictive and descriptive DM

# Types of DM tasks

- **Predictive DM:**
  - Classification (learning of rules, decision trees, ...)
  - Prediction and estimation (regression)
  - Predictive relational DM (ILP)
- **Descriptive DM:**
  - description and summarization
  - dependency analysis (association rule learning)
  - discovery of properties and constraints
  - segmentation (clustering)
  - subgroup discovery
- **Text, Web and image analysis**

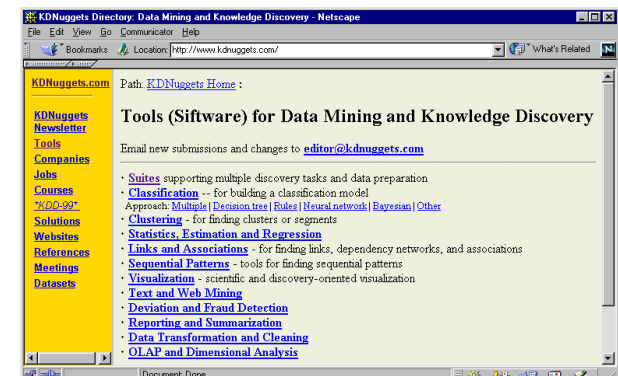
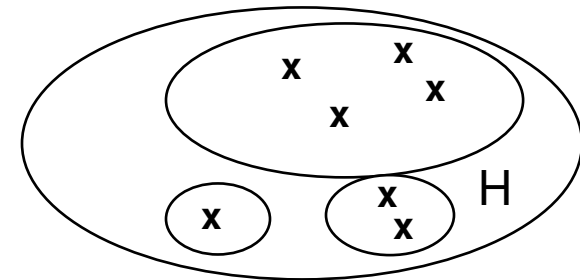
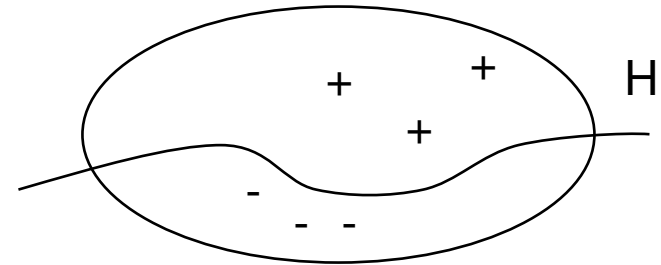

# Predictive vs. descriptive induction

**Predictive induction**

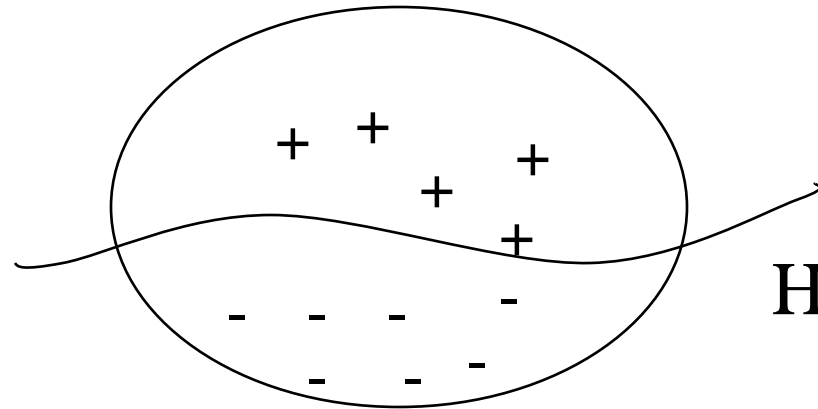

**Descriptive induction**

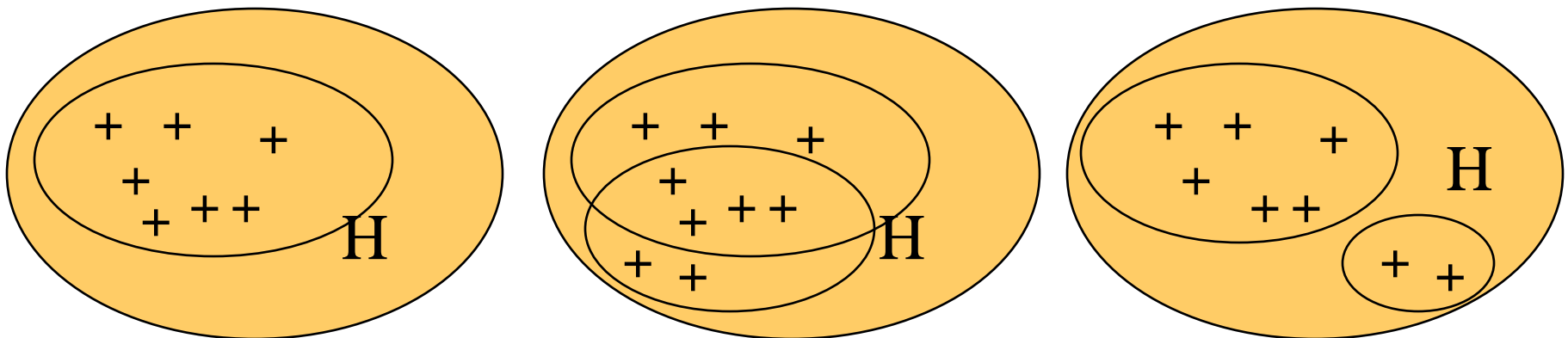

# Predictive vs. descriptive induction

- **Predictive induction:** Inducing classifiers for solving classification and prediction tasks,
  - Classification rule learning, Decision tree learning, ...
  - Bayesian classifier, ANN, SVM, ...
  - Data analysis through hypothesis generation and testing
- **Descriptive induction:** Discovering interesting regularities in the data, uncovering patterns, ... for solving KDD tasks
  - Symbolic clustering, Association rule learning, Subgroup discovery, ...
  - Exploratory data analysis

# Predictive DM formulated as a machine learning task:

- Given a set of labeled **training examples** (n-tuples of attribute values, labeled by class name)

	A1	A2	A3	Class
example1	$v_{1,1}$	$v_{1,2}$	$v_{1,3}$	$C_1$
example2	$v_{2,1}$	$v_{2,2}$	$v_{2,3}$	$C_2$

..

- By performing generalization from examples (induction) find a **hypothesis** (classification rules, decision tree, ...) which explains the training examples, e.g. rules of the form:

$$(A_i = v_{i,k}) \ \& \ (A_j = v_{j,l}) \ \& \ \dots \ \rightarrow \text{Class} = C_n$$

# Data Mining in a Nutshell

Person	Age	Spect. presc.	Astigm.	Tear prod.	Lenses
O1	young	myope	no	reduced	NONE
O2	young	myope	no	normal	SOFT
O3	young	myope	yes	reduced	NONE
O4	young	myope	yes	normal	HARD
O5	young	hypermetrope	no	reduced	NONE
O6-O13	...	...	...	...	...
O14	pre-presbyc	hypermetrope	no	normal	SOFT
O15	pre-presbyc	hypermetrope	yes	reduced	NONE
O16	pre-presbyc	hypermetrope	yes	normal	NONE
O17	presbyopic	myope	no	reduced	NONE
O18	presbyopic	myope	no	normal	NONE
O19-O23	...	...	...	...	...
O24	presbyopic	hypermetrope	yes	normal	NONE

data

knowledge discovery  
from data

Data Mining

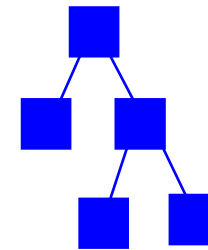

model, patterns, ...

**Given:** transaction data table, relational database, text documents, Web pages

**Find:** a classification model, a set of interesting patterns

# Data Mining in a Nutshell

Person	Age	Spect. presc.	Astigm.	Tear prod.	Lenses
O1	young	myope	no	reduced	NONE
O2	young	myope	no	normal	SOFT
O3	young	myope	yes	reduced	NONE
O4	young	myope	yes	normal	HARD
O5	young	hypermetrope	no	reduced	NONE
O6-O13	...	...	...	...	...
O14	pre-presbyc	hypermetrope	no	normal	SOFT
O15	pre-presbyc	hypermetrope	yes	reduced	NONE
O16	pre-presbyc	hypermetrope	yes	normal	NONE
O17	presbyopic	myope	no	reduced	NONE
O18	presbyopic	myope	no	normal	NONE
O19-O23	...	...	...	...	...
O24	presbyopic	hypermetrope	yes	normal	NONE

data

knowledge discovery  
from data

Data Mining

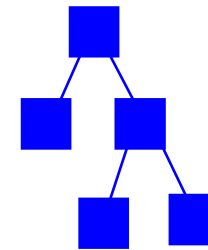

model, patterns, ...

**Given:** transaction data table, relational database, text documents, Web pages

**Find:** a classification model, a set of interesting patterns

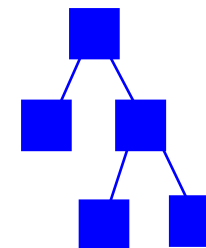
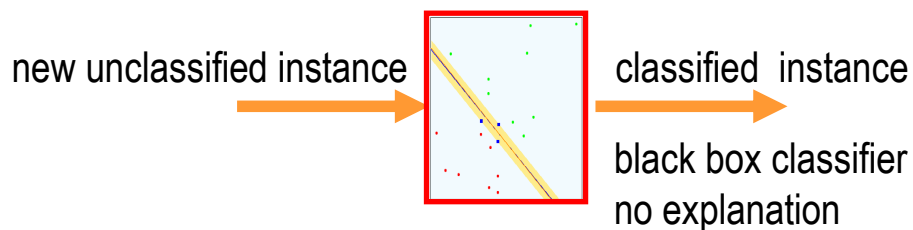

symbolic model  
symbolic patterns  
explanation





# Predictive DM - Classification

- data are objects, characterized with attributes - they belong to different classes (discrete labels)
- given objects described with attribute values, induce a model to predict different classes
- decision trees, if-then rules, discriminant analysis, ...

# Data mining example

## Input: Contact lens data

Person	Age	Spect. presc.	Astigm.	Tear prod.	Lenses
O1	young	myope	no	reduced	NONE
O2	young	myope	no	normal	SOFT
O3	young	myope	yes	reduced	NONE
O4	young	myope	yes	normal	HARD
O5	young	hypermetrope	no	reduced	NONE
O6-O13	...	...	...	...	...
O14	pre-presbyc	hypermetrope	no	normal	SOFT
O15	pre-presbyc	hypermetrope	yes	reduced	NONE
O16	pre-presbyc	hypermetrope	yes	normal	NONE
O17	presbyopic	myope	no	reduced	NONE
O18	presbyopic	myope	no	normal	NONE
O19-O23	...	...	...	...	...
O24	presbyopic	hypermetrope	yes	normal	NONE

# Contact lens data: Decision tree

**Type of task:** prediction and classification

**Hypothesis language:** decision trees

(nodes: attributes, arcs: values of attributes, leaves: classes)

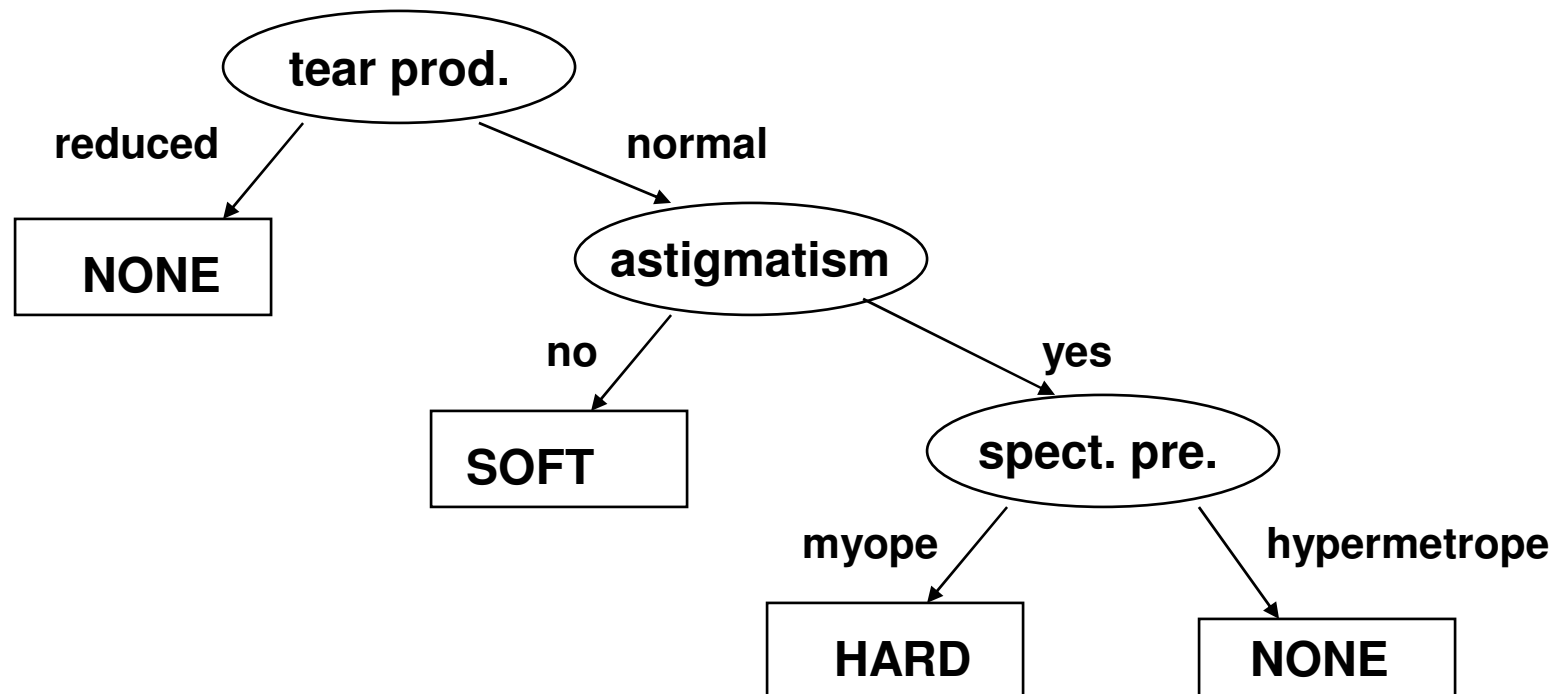

# Contact lens data: Classification rules

**Type of task:** prediction and classification

**Hypothesis language:** rules  $X \rightarrow C$ , if  $X$  then  $C$   
 $X$  conjunction of attribute values,  $C$  class

tear production=reduced  $\rightarrow$  **lenses=NONE**

tear production=normal & astigmatism=yes &  
spect. pre.=hypermetrope  $\rightarrow$  **lenses=NONE**

tear production=normal & astigmatism=no  $\rightarrow$   
**lenses=SOFT**

tear production=normal & astigmatism=yes &  
spect. pre.=myope  $\rightarrow$  **lenses=HARD**

DEFAULT **lenses=NONE**

## Task reformulation: Concept learning problem (positive vs. negative examples of Target class)

Person	Age	Spect. presc.	Astigm.	Tear prod.	Lenses
O1	young	myope	no	reduced	NO
O2	young	myope	no	normal	YES
O3	young	myope	yes	reduced	NO
O4	young	myope	yes	normal	YES
O5	young	hypermetrope	no	reduced	NO
O6-O13	...	...	...	...	...
O14	pre-presbyc	hypermetrope	no	normal	YES
O15	pre-presbyc	hypermetrope	yes	reduced	NO
O16	pre-presbyc	hypermetrope	yes	normal	NO
O17	presbyopic	myope	no	reduced	NO
O18	presbyopic	myope	no	normal	NO
O19-O23	...	...	...	...	...
O24	presbyopic	hypermetrope	yes	normal	NO

# Illustrative example: Customer data

Customer	Gender	Age	Income	Spent	BigSpender
c1	male	30	214000	18800	yes
c2	female	19	139000	15100	yes
c3	male	55	50000	12400	no
c4	female	48	26000	8600	no
c5	male	63	191000	28100	yes
O6-O13	...	...	...	...	...
c14	female	61	95000	18100	yes
c15	male	56	44000	12000	no
c16	male	36	102000	13800	no
c17	female	57	215000	29300	yes
c18	male	33	67000	9700	no
c19	female	26	95000	11000	no
c20	female	55	214000	28800	yes

# Customer data: Decision trees

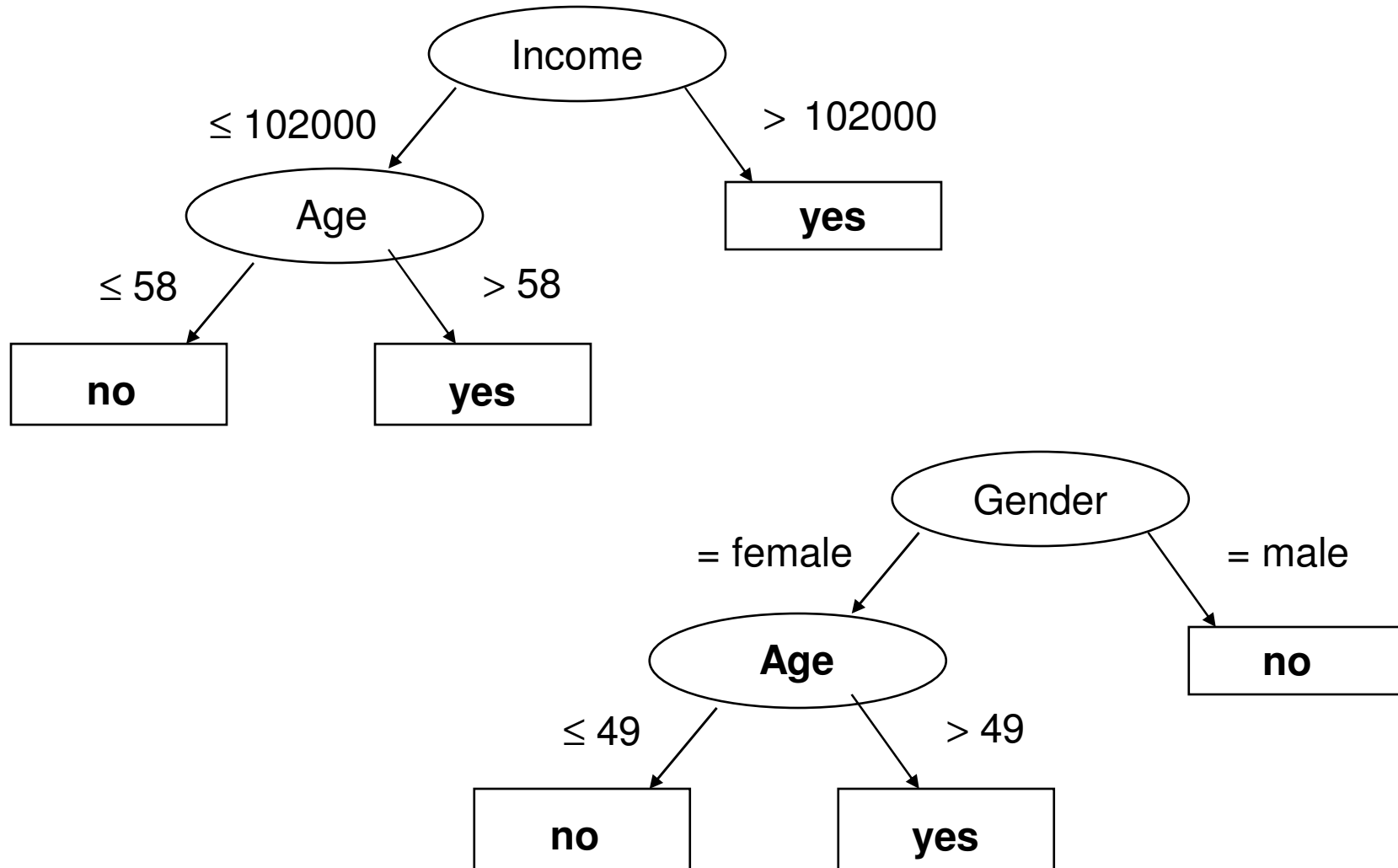

# Customer data: Association rules

**Type of task:** description (pattern discovery)

**Hypothesis language:** rules  $X \rightarrow Y$ , if X then Y

X, Y conjunctions of items (binary-valued attributes)

1. Age > 52 & BigSpender = no  $\rightarrow$  Sex = male
2. Age > 52 & BigSpender = no  $\rightarrow$   
Sex = male & Income  $\leq$  73250
3. Sex = male & Age > 52 & Income  $\leq$  73250  $\rightarrow$   
BigSpender = no



# Predictive DM - Estimation

- often referred to as regression
- data are objects, characterized with attributes (discrete or continuous), classes of objects are continuous (numeric)
- given objects described with attribute values, induce a model to predict the numeric class value
- regression trees, linear and logistic regression, ANN, kNN, ...

# Customer data: regression tree

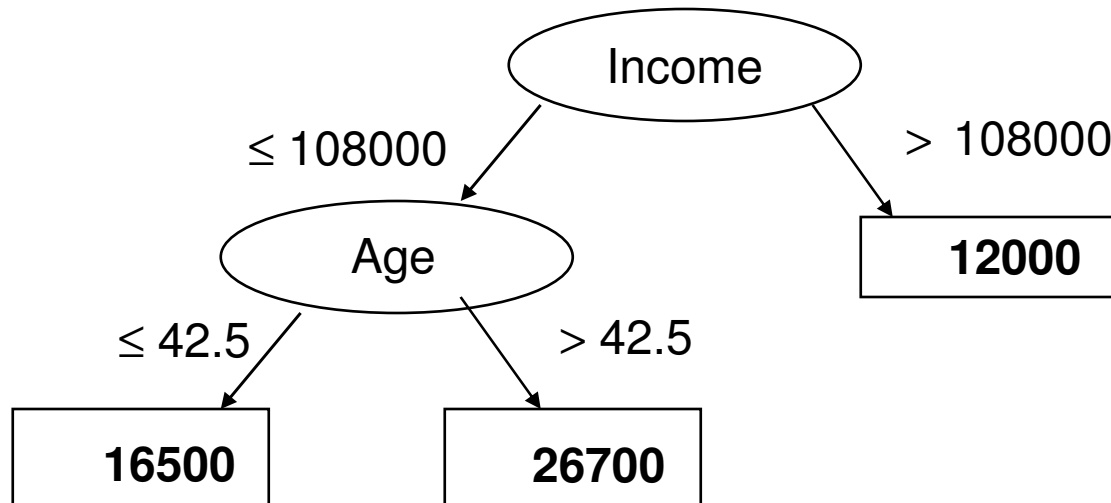

In the nodes one usually has  
Predicted value +- st. deviation

# Relational Data Mining (Inductive Logic Programming) in a Nutshell

customer							
ID	Zip	Sex	SoSt	Income	Age	Club	Resp
...	...	...	...	...	...	...	...
3478	34677	m	si	60-70	32	me	nr
3479	43666	f	ma	80-90	45	nr	re
...	...	...	...	...	...	...	...

order				
Customer ID	Order ID	Store ID	Delivery Mode	Paymt Mode
...	...	...	...	...
3478	2140267	12	regular	cash
3478	3446778	12	express	check
3478	4728386	17	regular	check
3479	3233444	17	express	credit
3479	3475886	12	regular	credit
...	...	...	...	...

store			
Store ID	Size	Type	Location
...	...	...	...
12	small	franchise	city
17	large	indep	rural
...	...	...	...

knowledge discovery  
from data

Relational Data Mining

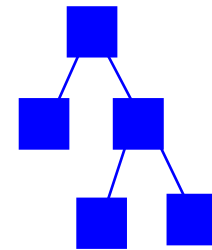

model, patterns, ...

Relational representation of customers, orders and stores.

**Given:** a relational database, a set of tables. sets of logical facts, a graph, ...

**Find:** a classification model, a set of interesting patterns

# Relational Data Mining (ILP)

- Learning from multiple tables
- Complex relational problems:
  - temporal data: time series in medicine, traffic control, ...
  - structured data: representation of molecules and their properties in protein engineering, biochemistry, ...

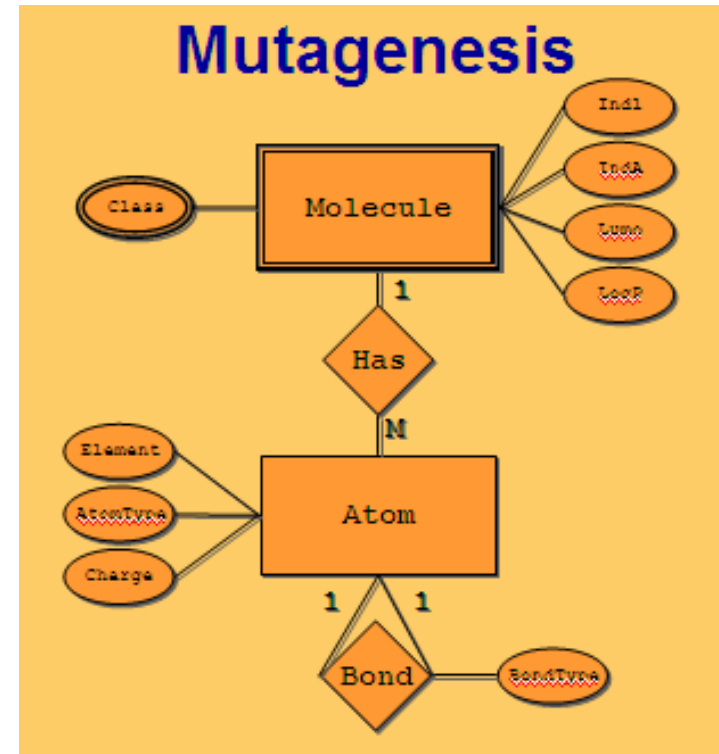

# Relational Data Mining (ILP)

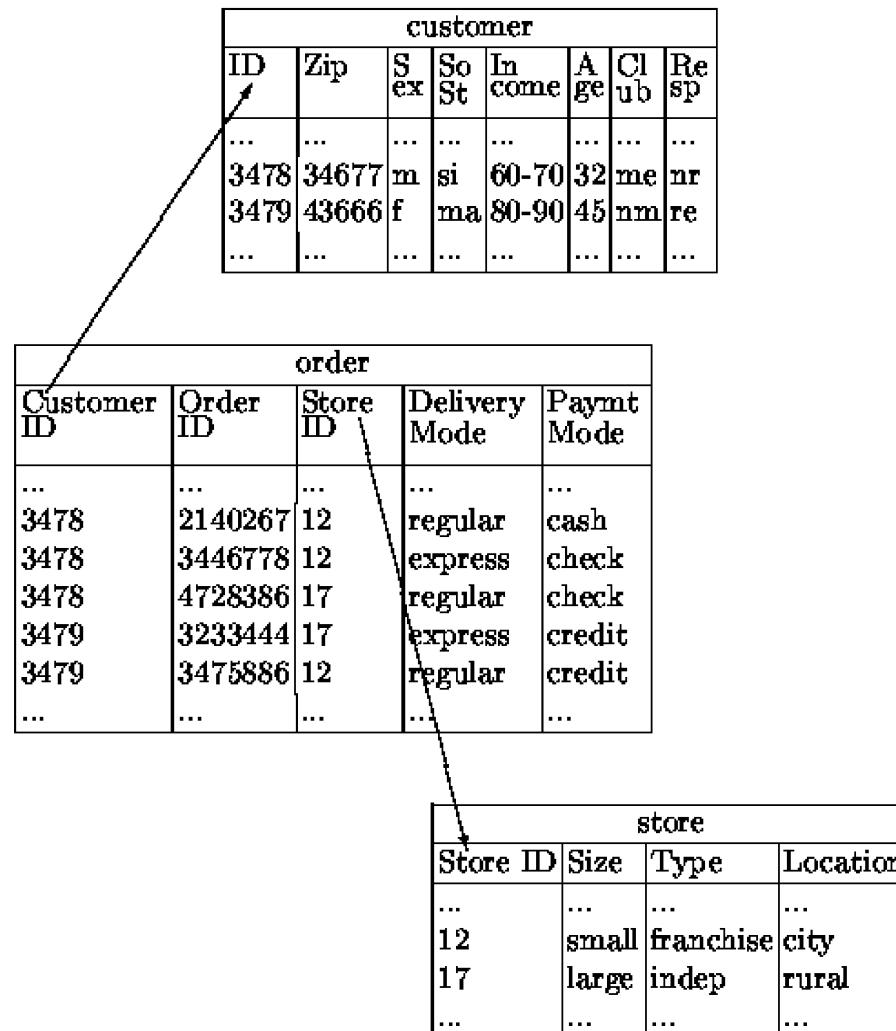

Relational representation of customers, orders and stores.

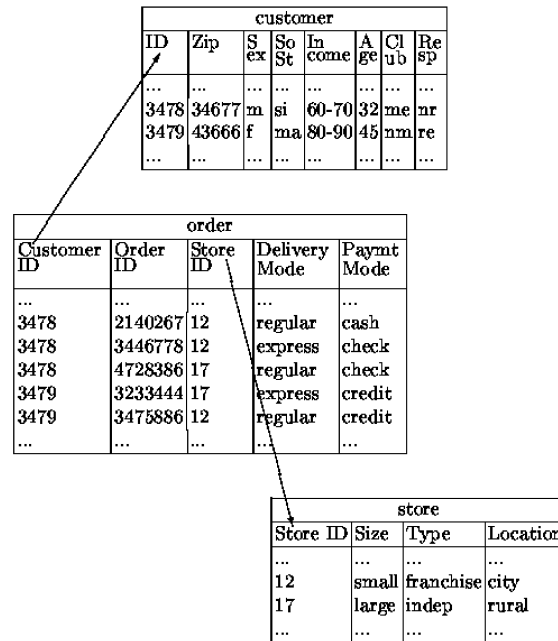

Relational representation of customers, orders and stores.

ID	Zip	Sex	Soc St	Income	Age	Club	Resp
...	...	...	...	...	...	...	...
3478	34667	m	si	60-70	32	me	nr
3479	43666	f	ma	80-90	45	nm	re
...	...	...	...	...	...	...	...

**Basic table for analysis**

ID	Zip	Sex	Soc St	Income	Age	Club	Resp
...	...	...	...	...	...	...	...
3478	34667	m	si	60-70	32	me	nr
3479	43666	f	ma	80-90	45	nm	re
...	...	...	...	...	...	...	...

**Data table presented as logical facts (Prolog format)**

`customer(Id,Zip,Sex,SoSt,In,Age,Club,Re)`

**Prolog facts describing data in Table 2:**

`customer(3478,34667,m,si,60-70,32,me,nr).`

`customer(3479,43666,f,ma,80-90,45,nm,re).`

**Expressing a property of a relation:**

`customer(____,f,____,____,____).`

# Relational Data Mining (ILP)

## Data bases:

- Name of relation  $p$
- Attribute of  $p$
- n-tuple  $\langle v_1, \dots, v_n \rangle =$  row in a relational table
- relation  $p =$  set of n-tuples = relational table

customer						
ID	Zip	Sex	State	Income	Age	Residence
...	...	...	...	...	...	...
3478	34677	m	si	60-70	32	urban
3479	43666	f	ma	80-90	45	rural
...	...	...	...	...	...	...

order				
Customer ID	Order ID	Store ID	Delivery Mode	Payment Mode
...	...	...	...	...
3478	2140267	12	regular	cash
3478	3446778	12	express	check
3478	4728386	17	regular	check
3479	3233444	17	express	credit
3479	3475886	12	regular	credit
...	...	...	...	...

store			
Store ID	Size	Type	Location
...	...	...	...
12	small	franchise	city
17	large	indep	rural
...	...	...	...

Relational representation of customers, orders and stores.

## Logic programming:

- Predicate symbol  $p$
- Argument of predicate  $p$
- Ground fact  $p(v_1, \dots, v_n)$
- Definition of predicate  $p$ 
  - Set of ground facts
  - Prolog clause or a set of Prolog clauses

## Example predicate definition:

```
good_customer(C) :-
customer(C,_,female,_,_,_,_),
order(C,_,_,_,creditcard).
```



# Part I: Summary

- KDD is the overall process of discovering useful knowledge in data
  - many steps including data preparation, cleaning, transformation, pre-processing
- Data Mining is the data analysis phase in KDD
  - DM takes only 15%-25% of the effort of the overall KDD process
  - employing techniques from machine learning and statistics
- Predictive and descriptive induction have different goals: classifier vs. pattern discovery
- Many application areas
- Many powerful tools available

# Introductory seminar lecture

## X. JSI & Knowledge Technologies

### I. Introduction

- Data Mining and KDD process
- DM standards, tools and visualization
- Classification of Data Mining techniques: Predictive and descriptive DM

(Mladenić et al. Ch. 1 and 11, Kononenko & Kukar Ch. 1)

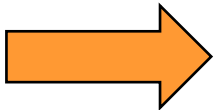

### **XX. Selected data mining techniques: Advanced subgroup discovery techniques and applications**

### **XXX. Recent advances: Cross-context link discovery**

## XX. Talk outline

- 
- Data mining in a nutshell revisited
    - Subgroup discovery in a nutshell
    - Relational data mining and propositionalization in a nutshell
    - Semantic data mining: Using ontologies in SD

# Data Mining in a nutshell

Person	Age	Spect. presc.	Astigm.	Tear prod.	Lenses
O1	young	myope	no	reduced	NONE
O2	young	myope	no	normal	SOFT
O3	young	myope	yes	reduced	NONE
O4	young	myope	yes	normal	HARD
O5	young	hypermetrope	no	reduced	NONE
O6-O13	...	...	...	...	...
O14	pre-presbyc	hypermetrope	no	normal	SOFT
O15	pre-presbyc	hypermetrope	yes	reduced	NONE
O16	pre-presbyc	hypermetrope	yes	normal	NONE
O17	presbyopic	myope	no	reduced	NONE
O18	presbyopic	myope	no	normal	NONE
O19-O23	...	...	...	...	...
O24	presbyopic	hypermetrope	yes	normal	NONE

data

knowledge discovery  
from data

Data Mining

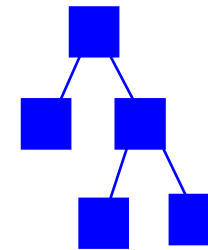

model, patterns, ...

**Given:** transaction data table, relational database, text documents, Web pages

**Find:** a classification model, a set of interesting patterns

# Example: Learning a classification model from contact lens data

Person	Age	Spect. presc.	Astigm.	Tear prod.	Lenses
O1	young	myope	no	reduced	NONE
O2	young	myope	no	normal	SOFT
O3	young	myope	yes	reduced	NONE
O4	young	myope	yes	normal	HARD
O5	young	hypermetrope	no	reduced	NONE
O6-O13	...	...	...	...	...
O14	pre-presbyc	hypermetrope	no	normal	SOFT
O15	pre-presbyc	hypermetrope	yes	reduced	NONE
O16	pre-presbyc	hypermetrope	yes	normal	NONE
O17	presbyopic	myope	no	reduced	NONE
O18	presbyopic	myope	no	normal	NONE
O19-O23	...	...	...	...	...
O24	presbyopic	hypermetrope	yes	normal	NONE



# Example: Learning a classification model from contact lens data

Person	Age	Spect. presc.	Astigm.	Tear prod.	Lenses
O1	young	myope	no	reduced	NONE
O2	young	myope	no	normal	SOFT
O3	young	myope	yes	reduced	NONE
O4	young	myope	yes	normal	HARD
O5	young	hypermetrope	no	reduced	NONE
O6-O13	...	...	...	...	...
O14	pre-presbyc	hypermetrope	no	normal	SOFT
O15	pre-presbyc	hypermetrope	yes	reduced	NONE
O16	pre-presbyc	hypermetrope	yes	normal	NONE
O17	presbyopic	myope	no	reduced	NONE
O18	presbyopic	myope	no	normal	NONE
O19-O23	...	...	...	...	...
O24	presbyopic	hypermetrope	yes	normal	NONE

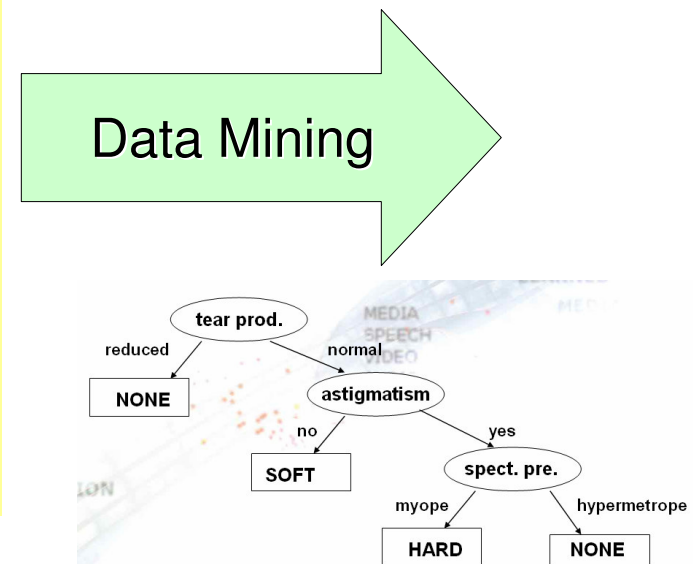

**lenses=NONE** ← tear production=reduced

**lenses=NONE** ← tear production=normal & astigmatism=yes & spect. pre.=hypermetrope

**lenses=SOFT** ← tear production=normal & astigmatism=no

**lenses=HARD** ← tear production=normal & astigmatism=yes & spect. pre.=myope

**lenses=NONE** ←

# Data/task reformulation

Person	Age	Spect. presc.	Astigm.	Tear prod.	Lenses
O1	young	myope	no	reduced	NO
O2	young	myope	no	normal	YES
O3	young	myope	yes	reduced	NO
O4	young	myope	yes	normal	YES
O5	young	hypermetrope	no	reduced	NO
O6-O13	...	...	...	...	...
O14	pre-presbyc	hypermetrope	no	normal	YES
O15	pre-presbyc	hypermetrope	yes	reduced	NO
O16	pre-presbyc	hypermetrope	yes	normal	NO
O17	presbyopic	myope	no	reduced	NO
O18	presbyopic	myope	no	normal	NO
O19-O23	...	...	...	...	...
O24	presbyopic	hypermetrope	yes	normal	NO

## Data/task reformulation:

Positive (vs. negative) examples of the Target class

- for Concept learning (predictive induction)
- for Subgroup discovery (descriptive pattern induction)

# Classification versus Subgroup Discovery

- **Classification (predictive induction) - constructing sets of classification rules**
  - aimed at learning a model for classification or prediction
  - rules are dependent
- **Subgroup discovery (descriptive induction) – constructing individual subgroup describing rules**
  - aimed at finding interesting patterns in target class examples
    - large subgroups (high target class coverage)
    - with significantly different distribution of target class examples (high TP/FP ratio, high significance, high WRAcc)
  - each rule (pattern) is an independent chunk of knowledge



# Classification versus Subgroup discovery

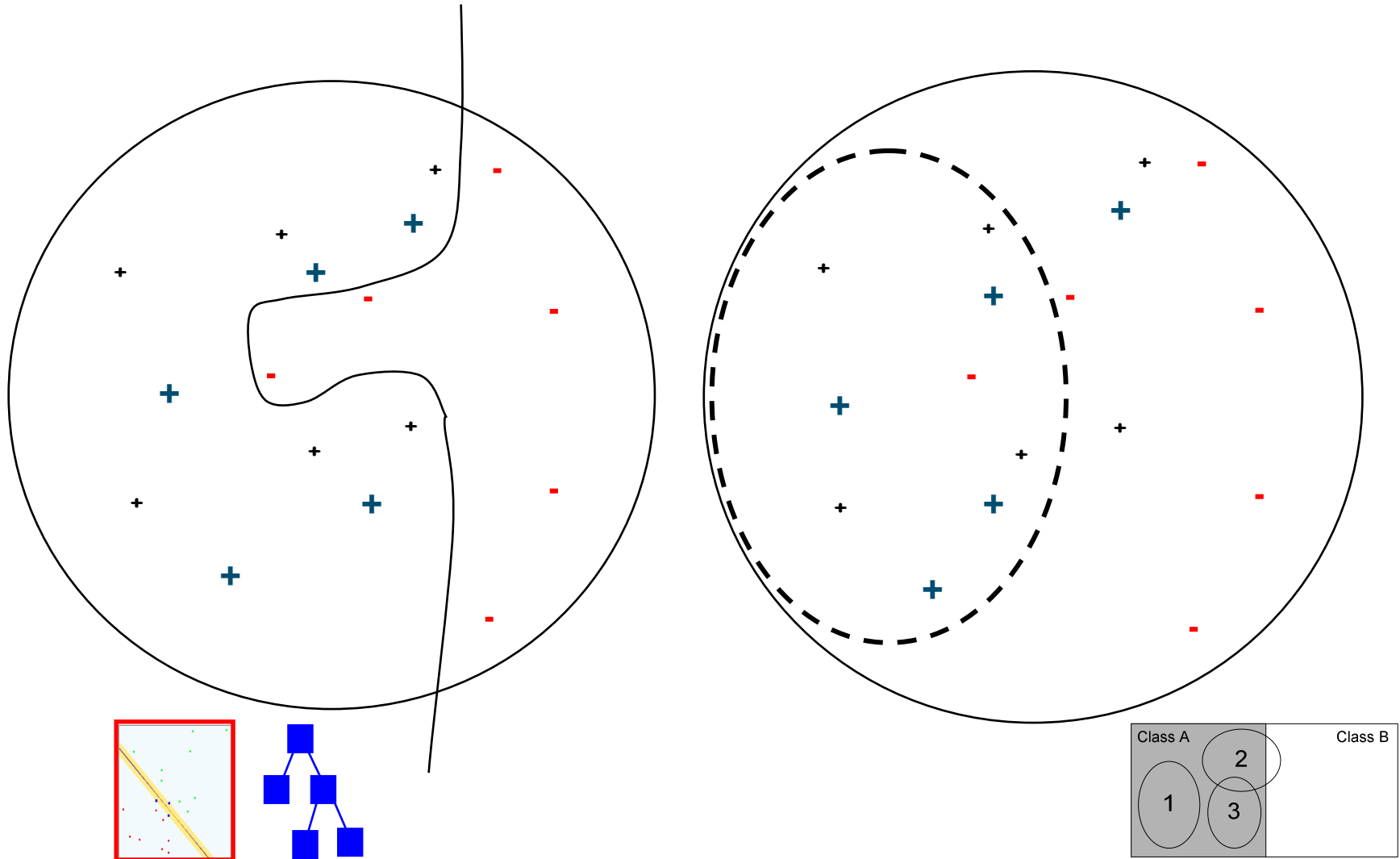

## XX. Talk outline

- Data mining in a nutshell revisited
- Subgroup discovery in a nutshell
- Relational data mining and propositionalization in a nutshell
- Semantic data mining: Using ontologies in SD

# Subgroup discovery task

## Task definition (Kloesgen, Wrobel 1997)

- **Given:** a population of individuals and a property of interest (target class, e.g. CHD)
- **Find:** `most interesting' descriptions of population subgroups
  - are as large as possible  
(high target class coverage)
  - have most unusual distribution of the target property  
(high TP/FP ratio, high significance)

# Subgroup discovery example: CHD Risk Group Detection

**Input:** Patient records described by **stage A** (anamnestic), stage **B** (an. & lab.), and **stage C** (an., lab. & ECG) attributes

**Task:** Find and characterize population subgroups with high CHD risk (large enough, distributionally unusual)

From **best induced descriptions**, five were selected by the expert as **most actionable** for CHD risk screening (by GPs):

CHD-risk ← male & pos. fam. history & age > 46

CHD-risk ← female & bodymassIndex > 25 & age > 63

CHD-risk ← ...

CHD-risk ← ...

CHD-risk ← ...

# Subgroup discovery algorithms

- EXPLORA (Kloesgen, Wrobel 1996)
- MIDOS (Wrobel, PKDD 1997)
- SD algorithm (Gamberger & Lavrac, JAIR 2002)
- APRIORI-SD (Kavsek & Lavrac, AAI 2006)
- CN2-SD (Lavrac et al., JMLR 2004): Adapting CN2 classification rule learner to Subgroup Discovery:
  - Weighted covering algorithm
  - Weighted relative accuracy (WRAcc) search heuristics, with added example weights
- Numerous other recent approaches ...

# Characteristics of SD Algorithms

- SD algorithms do not look for a single complex rule to describe all examples of target class A (all CHD-risk patients), but several rules that describe parts (subgroups) of A.

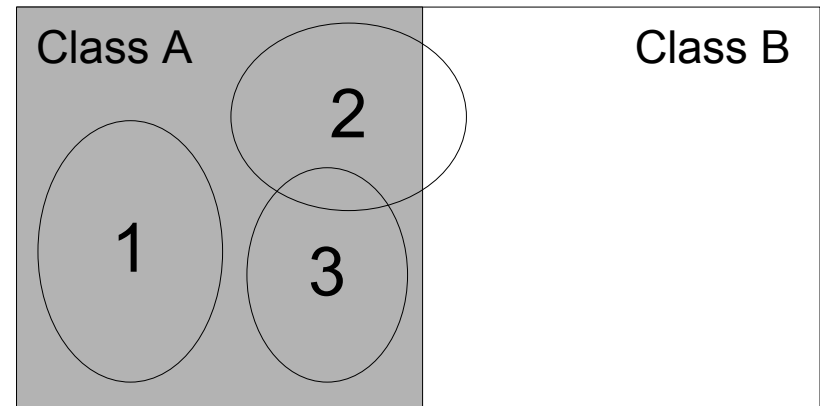

# Characteristics of SD Algorithms

- SD algorithms do not look for a single complex rule to describe all examples of target class A (all CHD-risk patients), but several rules that describe parts (subgroups) of A.
- SD algorithms naturally use example weights in their procedure for repetitive subgroup generation, via the weighted covering algo., and rule quality evaluation heuristics.

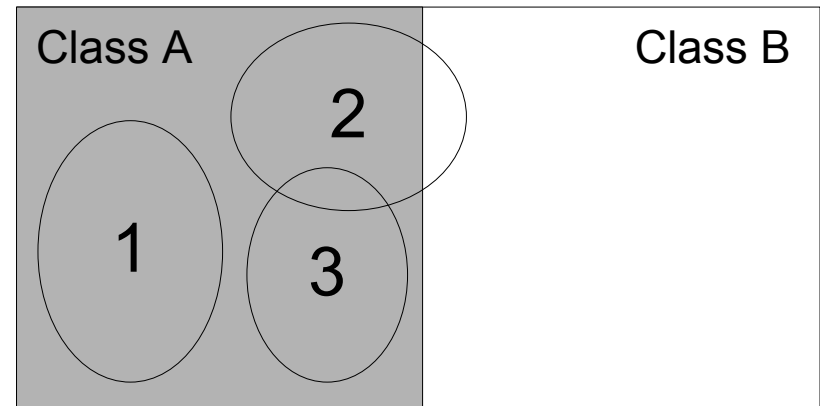

# Weighted covering algorithm for rule set construction

CHD patients

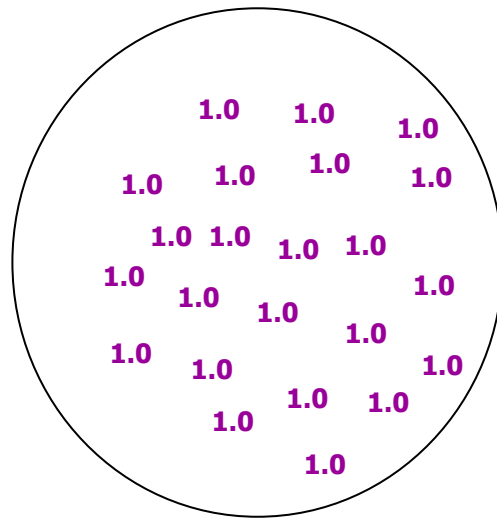

other patients

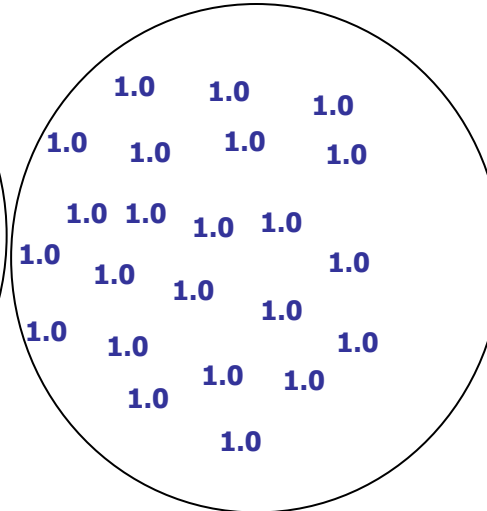

- For learning a set of subgroup describing rules, SD implements an iterative weighed covering algorithm.
- Quality of a rule is measured by trading off coverage and precision.



# Weighted covering algorithm for rule set construction

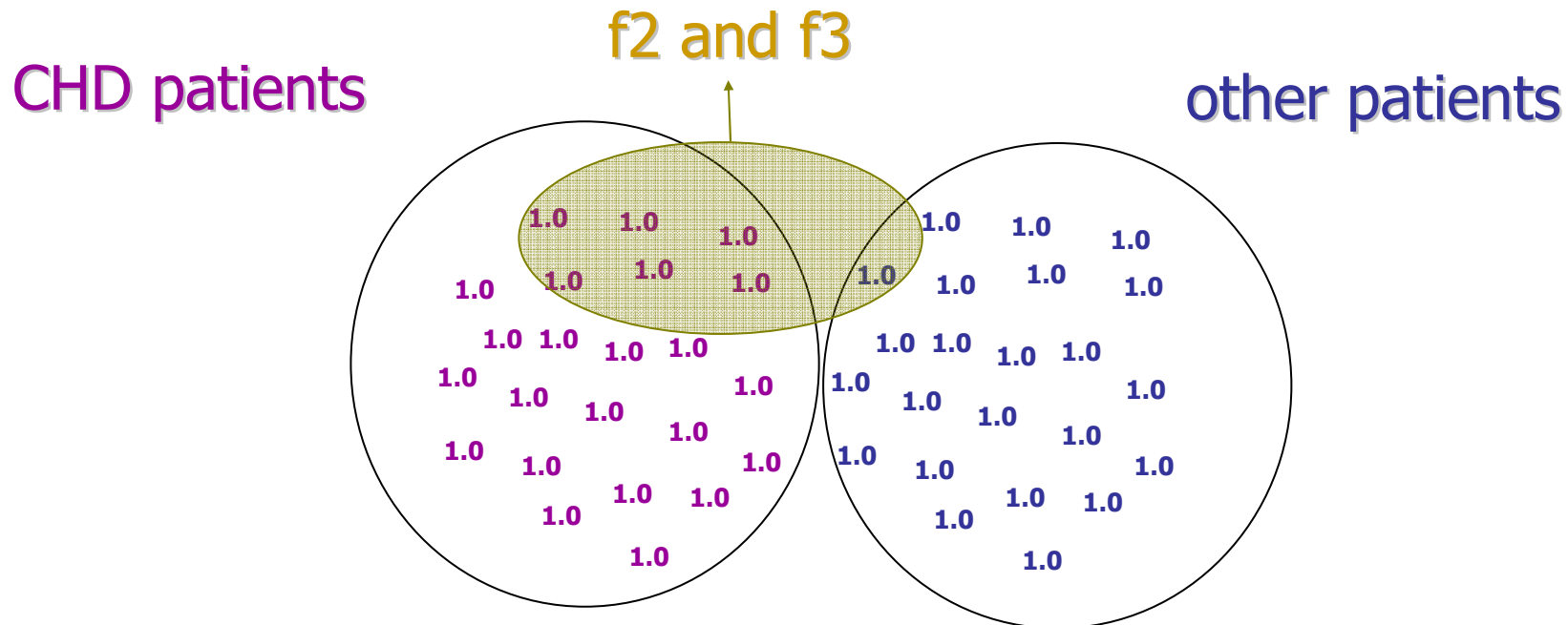

**Rule quality measure in SD:**  $q(\text{Cl} \leftarrow \text{Cond}) = \text{TP}/(\text{FP}+g)$

**Rule quality measure in CN2-SD:**  $\text{WRAcc}(\text{Cl} \leftarrow \text{Cond}) = p(\text{Cond}) \times [p(\text{Cl} | \text{Cond}) - p(\text{Cl})] = \text{coverage} \times (\text{precision} - \text{default precision})$

\***Coverage** = sum of the covered weights, \***Precision** = purity of the covered examples

# Weighted covering algorithm for rule set construction

CHD patients

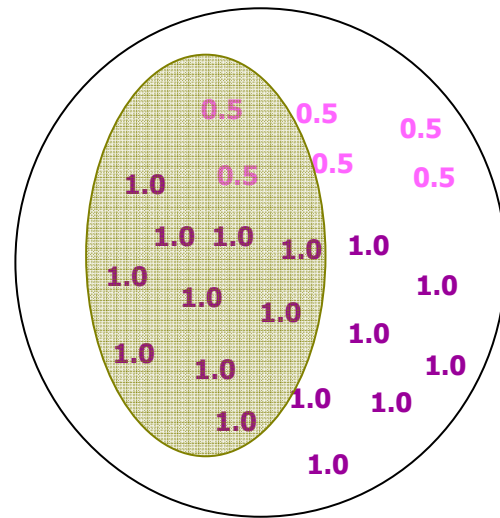

other patients

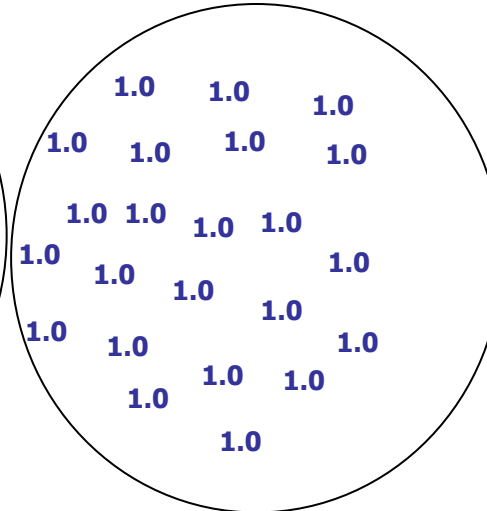

In contrast with classification rule learning algorithms (e.g. CN2), the covered positive examples are not deleted from the training set in the next rule learning iteration; they are re-weighted, and a next 'best' rule is learned.

# Subgroup visualization

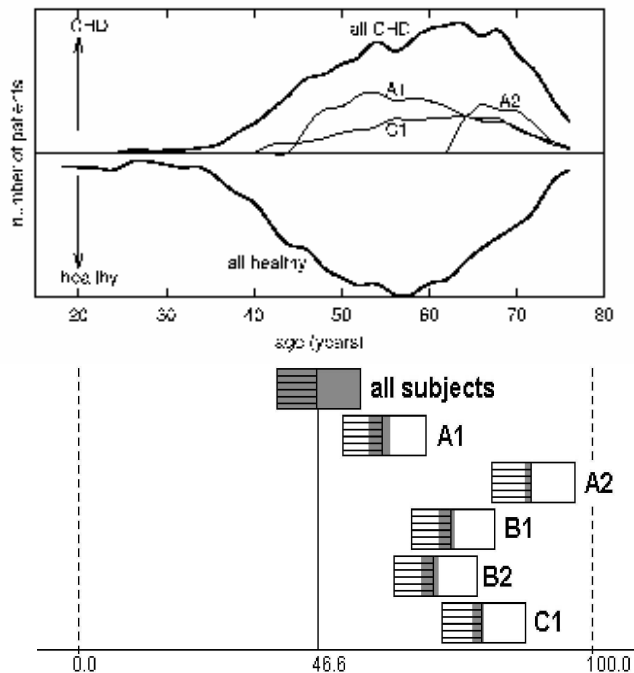
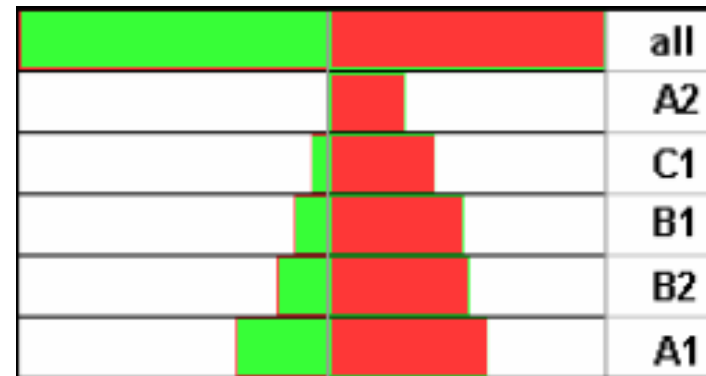
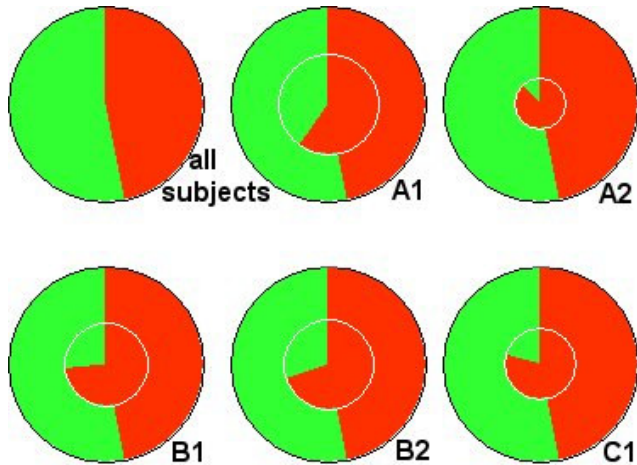

**The CHD task:** Find, characterize and visualize population subgroups with high CHD risk (large enough, distributionally unusual, most actionable)

# Induced subgroups and their statistical characterization

## Subgroup A2 for female patients:

High-CHD-risk **IF**

body mass index over  $25 \text{ kg/m}^2$  (typically 29)

**AND**

age over 63 years

**Supporting characteristics** (computed using  $\chi^2$  statistical significance test) are: positive family history and hypertension. Women in this risk group typically have slightly increased LDL cholesterol values and normal but decreased HDL cholesterol values.

## XX. Talk outline

- Data mining in a nutshell revisited
- Subgroup discovery in a nutshell
- Relational data mining and propositionalization in a nutshell
- Semantic data mining: Using ontologies in SD

# Relational Data Mining (Inductive Logic Programming) in a nutshell

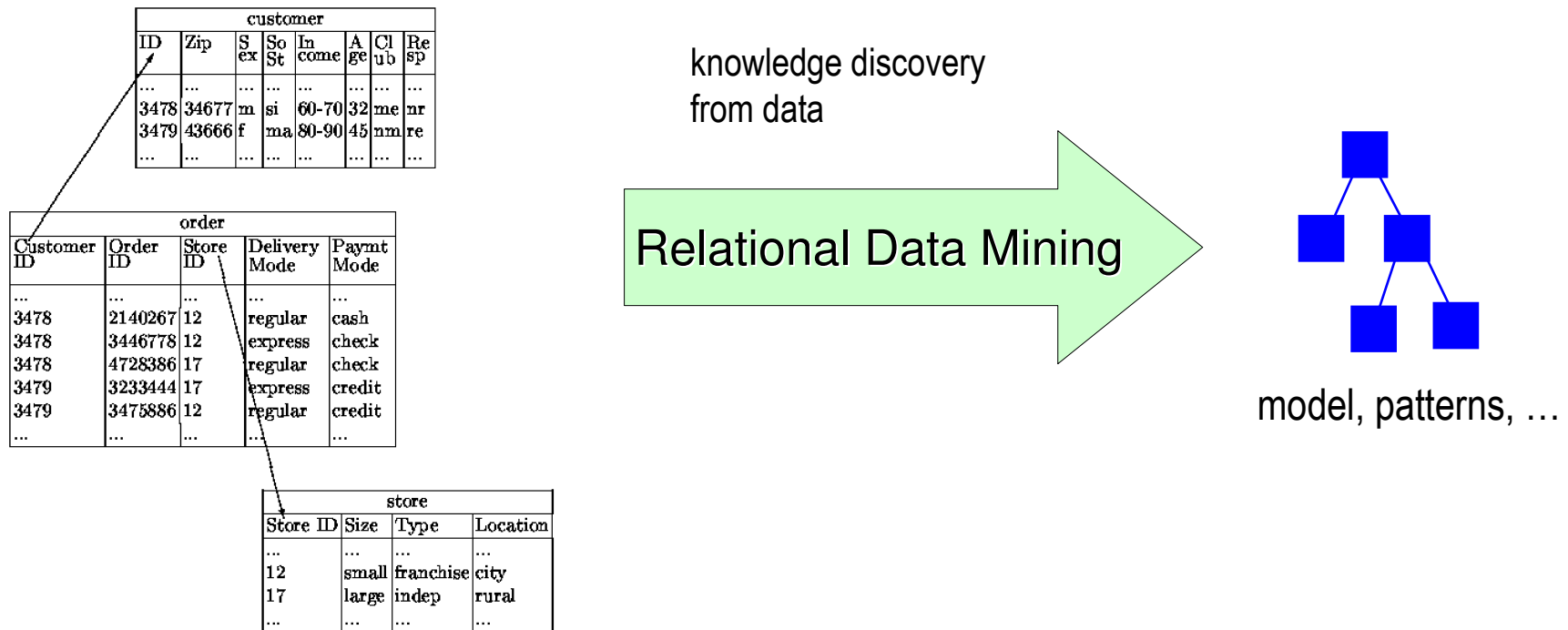

Relational representation of customers, orders and stores.

**Given:** a relational database, a set of tables. sets of logical facts, a graph, ...

**Find:** a classification model, a set of interesting patterns

# Sample ILP problem: East-West trains

## 1. TRAINS GOING EAST

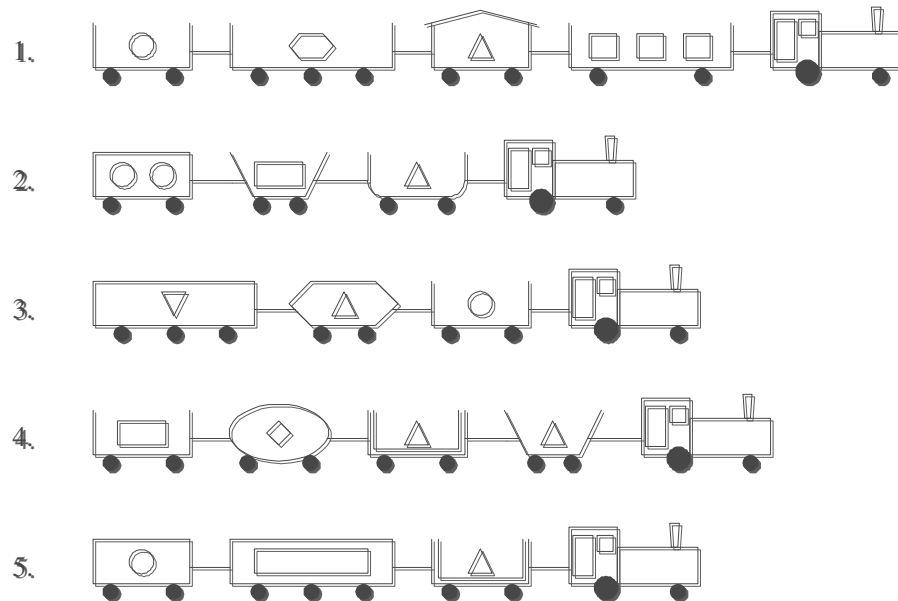

## 2. TRAINS GOING WEST

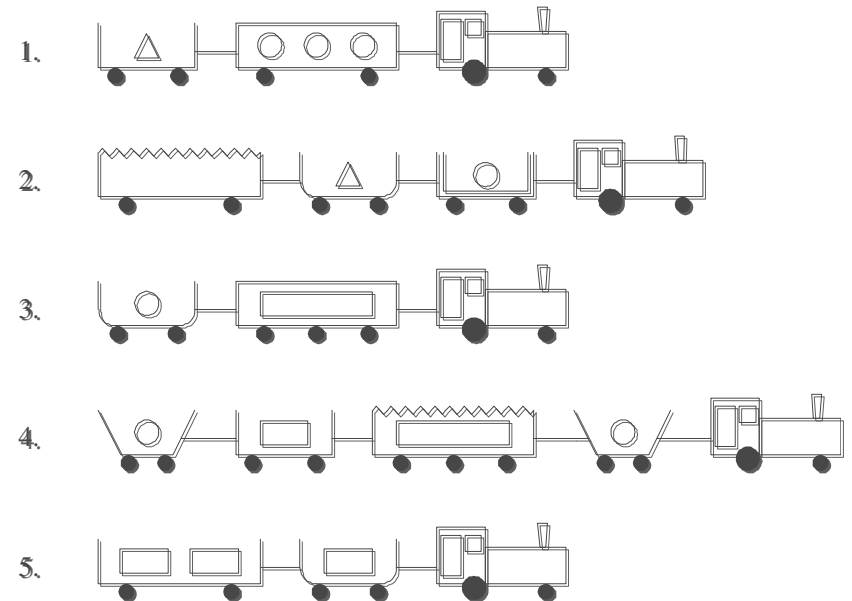

# Relational data representation



LOAD	CAR	OBJECT	NUMBER
l1	c1	circle	1
l2	c2	hexagon	1
l3	c3	triangle	1
l4	c4	rectangle	3
...	...	...	...

**TRAIN\_TABLE**

TRAIN	EASTBOUND
t1	TRUE
t2	TRUE
...	...
t6	FALSE
...	...

CAR	TRAIN	SHAPE	LENGTH	ROOF	WHEELS
c1	t1	rectangle	short	none	2
c2	t1	rectangle	long	none	3
c3	t1	rectangle	short	peaked	2
c4	t1	rectangle	long	none	2
...	...	...	...	...	...



# Relational data representation



LOAD	CAR	OBJECT	NUMBER
l1	c1	circle	1
l2	c2	hexagon	1
l3	c3	triangle	1
l4	c4	rectangle	3
...	...	...	...

**TRAIN\_TABLE**

TRAIN	EASTBOUND
t1	TRUE
t2	TRUE
...	...
t6	FAL SE
...	...

CAR	TRAIN	SHAPE	LENGTH	ROOF	WHEELS
c1	t1	rectangle	short	none	2
c2	t1	rectangle	long	none	3
c3	t1	rectangle	short	peaked	2
c4	t1	rectangle	long	none	2
...	...	...	...	...	...

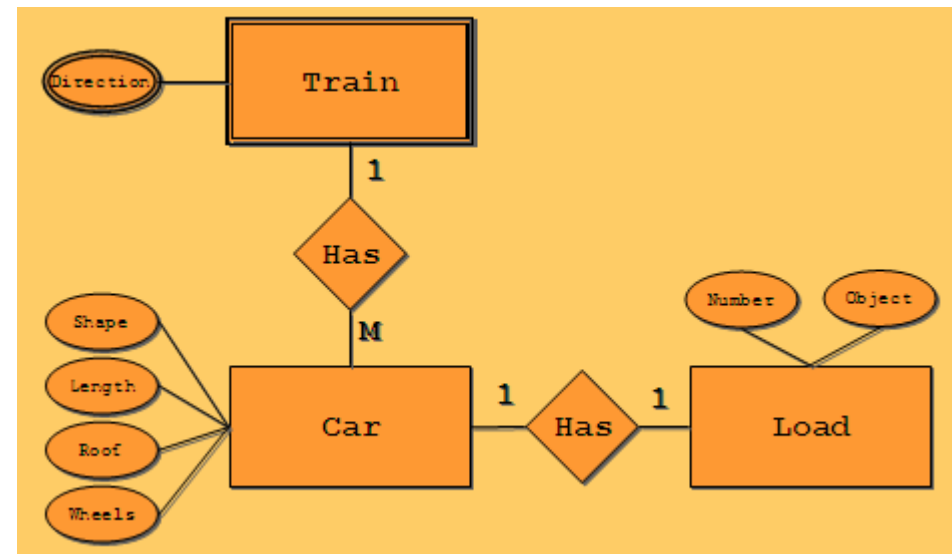

# Propositionalization in a nutshell



## Propositionalization task

**Transform** a multi-relational  
(**multiple-table**)  
representation to a  
propositional representation  
(**single table**)

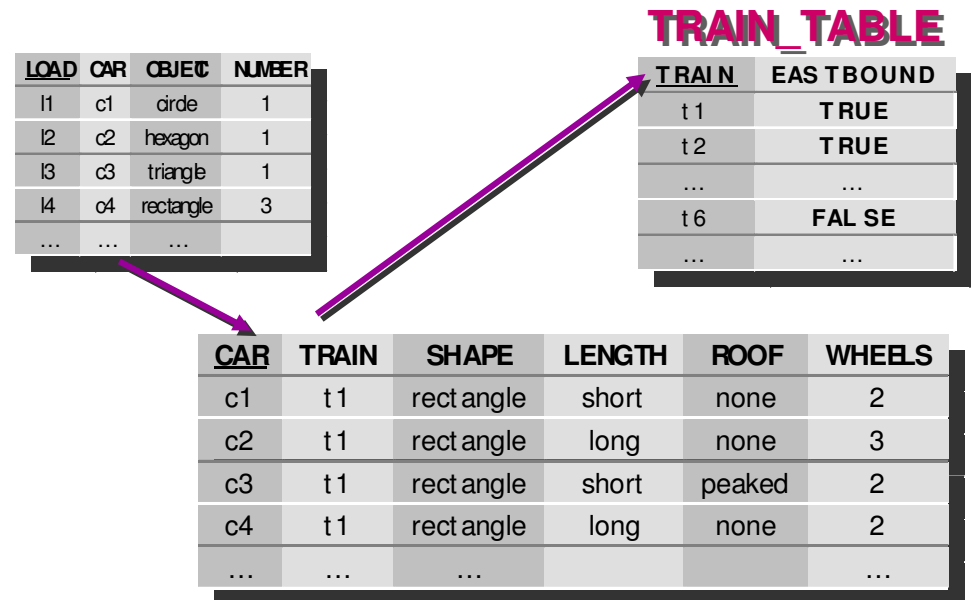

Proposed in ILP systems  
LINUS (Lavraç et al. 1991, 1994),  
1BC (Flach and Lachiche 1999), ...

# Propositionalization in a nutshell

**Main propositionalization step:  
first-order feature construction**

$f_1(T) :- \text{hasCar}(T, C), \text{clength}(C, \text{short}).$

$f_2(T) :- \text{hasCar}(T, C), \text{hasLoad}(C, L),$   
 $\text{loadShape}(L, \text{circle})$

$f_3(T) :- \dots$

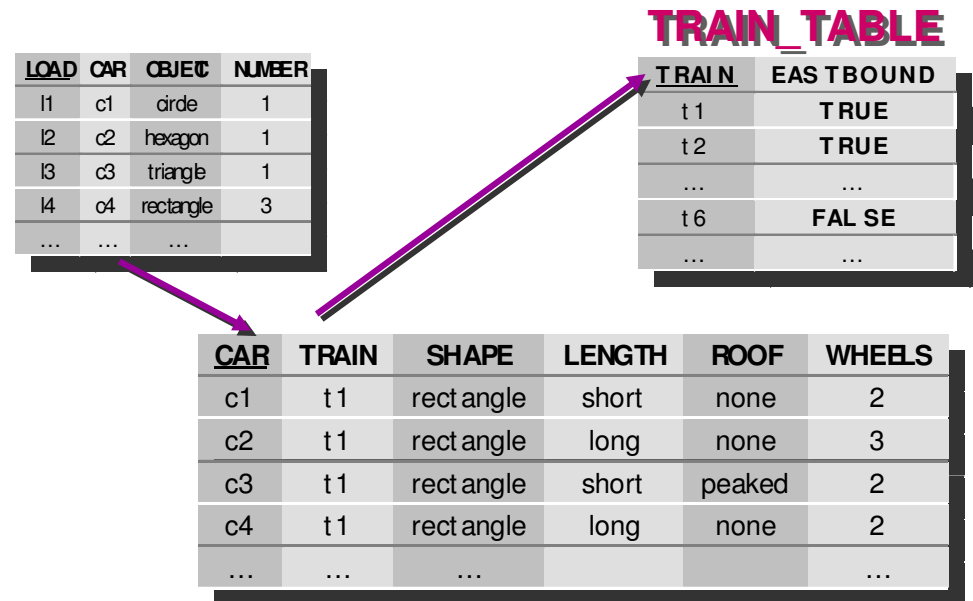

**Propositional learning:**

$t(T) \leftarrow f_1(T), f_4(T)$

**Relational interpretation:**

$\text{eastbound}(T) \leftarrow$

$\text{hasShortCar}(T), \text{hasClosedCar}(T).$

**PROPOSITIONAL TRAIN\_TABLE**

<u>train(T)</u>	<u>f1(T)</u>	<u>f2(T)</u>	<u>f3(T)</u>	<u>f4(T)</u>	<u>f5(T)</u>
t1	t	t	f	t	t
t2	t	t	t	t	t
t3	f	f	t	f	f
t4	t	f	t	f	f
...	...	...			...

# Relational Subgroup Discovery by upgrading CN2-SD

RSD algorithm (Zelezny and Lavrac, MLJ 2006)

- Implementing an propositionalization approach to relational learning, through efficient first-order feature construction
  - Syntax-driven feature construction, using Progol/Aleph style of modeb/modeh declaration
 

```
f121(M):- hasAtom(M,A), atomType(A,21)
f235(M):- lumo(M,Lu), lessThr(Lu,1.21)
```
- Using CN2-SD for propositional subgroup discovery
 

```
mutagenic(M) ← feature121(M), feature235(M)
```

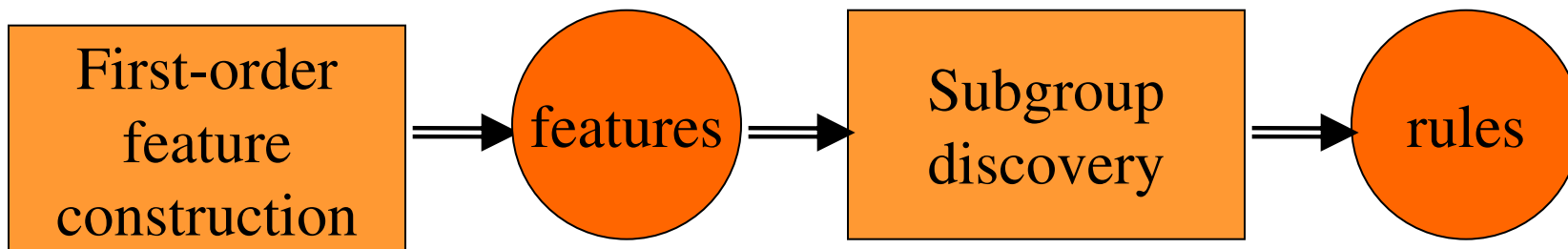
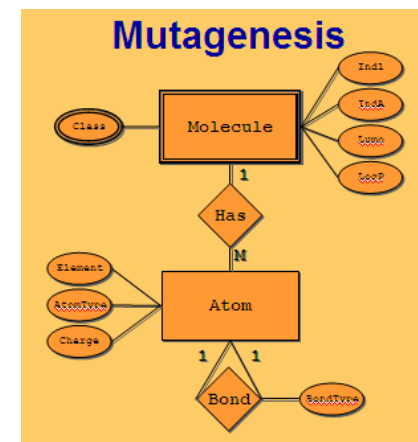

## RSD Lessons learned

Efficient propositionalization can be applied to individual-centered, multi-instance learning problems:

- one free global variable (denoting an individual, e.g. molecule M)
- one or more structural predicates: (e.g. `has_atom(M,A)`), each introducing a new existential local variable (e.g. atom A), using either the global variable (M) or a local variable introduced by other structural predicates (A)
- one or more utility predicates defining properties of individuals or their parts, assigning values to variables

`feature121(M):- hasAtom(M,A), atomType(A,21)`

`feature235(M):- lumo(M,Lu), lessThr(Lu,-1.21)`

`mutagenic(M):- feature121(M), feature235(M)`

# Talk outline

- Data mining in a nutshell revisited
- Subgroup discovery in a nutshell
- Relational data mining and propositionalization in a nutshell
- Semantic data mining: Using ontologies in SD
- Recent advances: cross-context bisociative link discovery

# Semantic Data Mining: Using ontologies in data mining

Exploiting two aspects of semantics in data mining

- Using **domain ontologies** as background knowledge for data mining, using propositionalization as means of information fusion for
  - Discovering predictive rules
  - Extracting pattern (frequent pattern mining, subgroup discovery,...) - Presented in this talk
- Developing a **Data Mining ontology** and using it for automated data mining workflow composition
  - Out of scope of this talk (see e.g.papers of ECML/PKDD-09 SoKD Workshop)

# Gene Ontology (GO)

- GO is a database of terms for genes:
  - **Function** - What does the gene product do?
  - **Process** - Why does it perform these activities?
  - **Component** - Where does it act?

12093 biological process  
 1812 cellular components  
 7459 molecular functions

- Known genes are annotated to GO terms  
 ([www.ncbi.nlm.nih.gov](http://www.ncbi.nlm.nih.gov))
- Terms are connected as a directed acyclic graph (**is\_a**, **part\_of**)
- Levels represent specificity of the terms

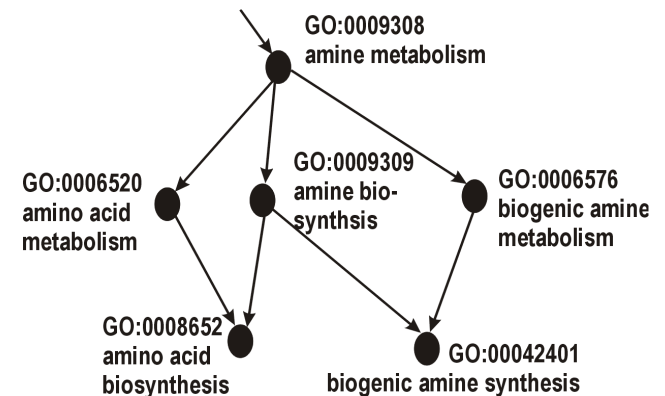



# Using domain ontologies (e.g. Gene Ontology) as background knowledge for Data Mining

## Gene Ontology

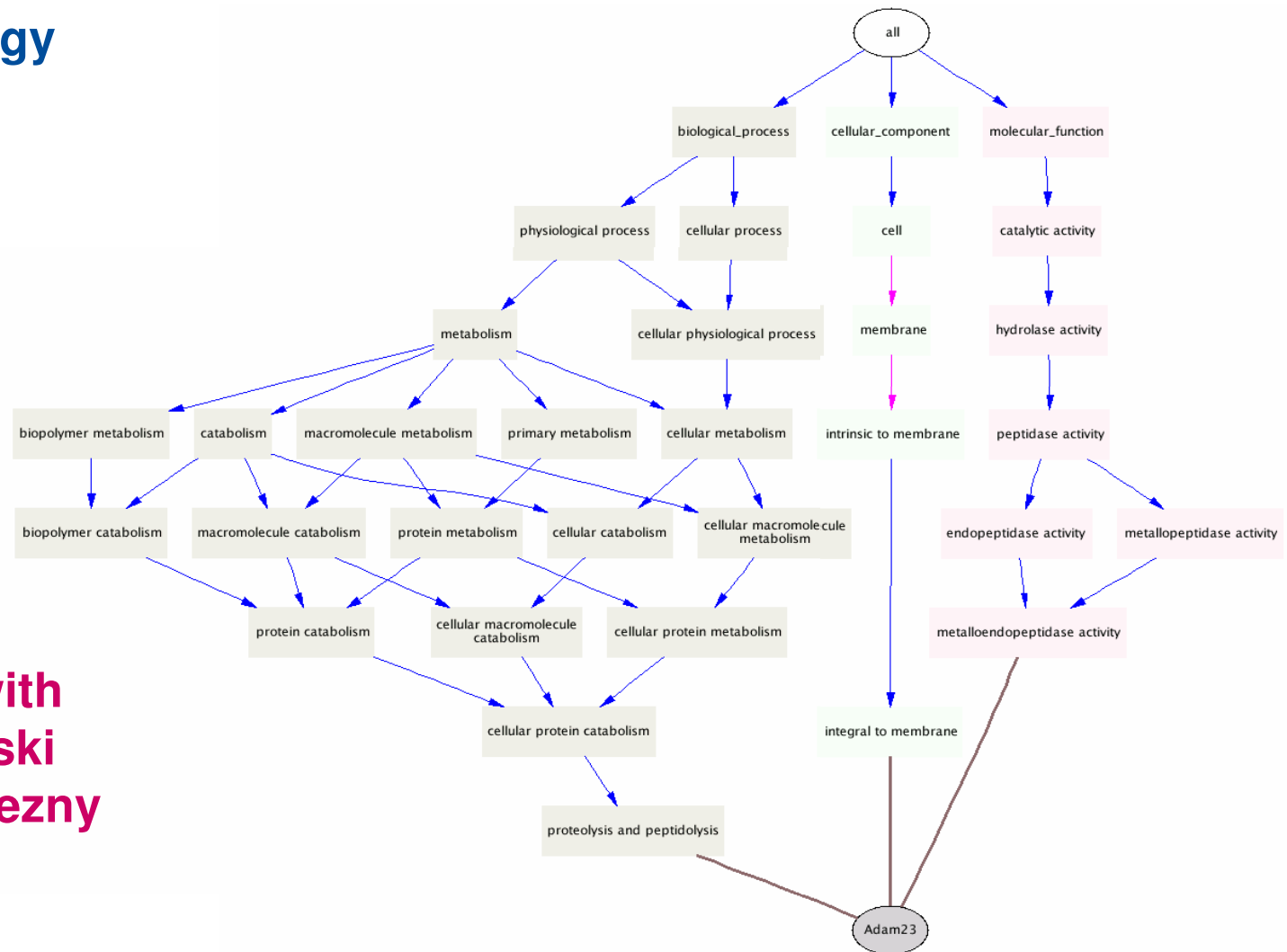

Joint work with  
Igor Trajkovski  
and Filip Zelezny

# Multi-Relational representation

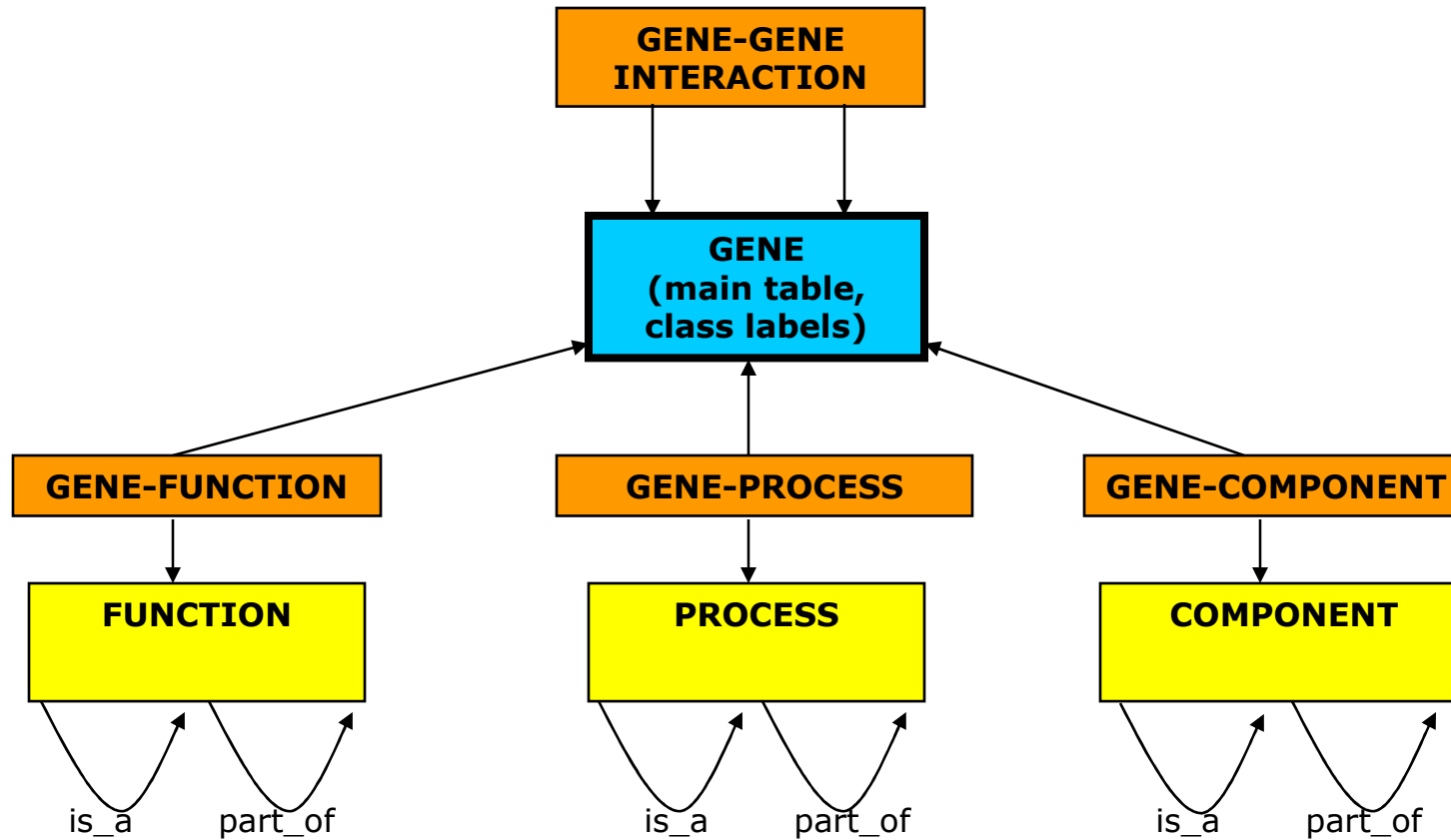

# Ontology encoded as relational background knowledge (Prolog facts)

## Prolog facts:

```
predicate(geneID, CONSTANT).  
interaction(geneID, geneID).
```

```
component(2532, 'GO:0016020').  
component(2532, 'GO:0005886').  
component(2534, 'GO:0008372').  
function(2534, 'GO:0030554').  
function(2534, 'GO:0005524').  
process(2534, 'GO:0007243').  
interaction(2534, 5155).  
interaction(2534, 4803).
```

Basic, plus generalized background knowledge using GO

zinc ion binding ->

metal ion binding, ion binding, binding

# Sample microarray data analysis tasks

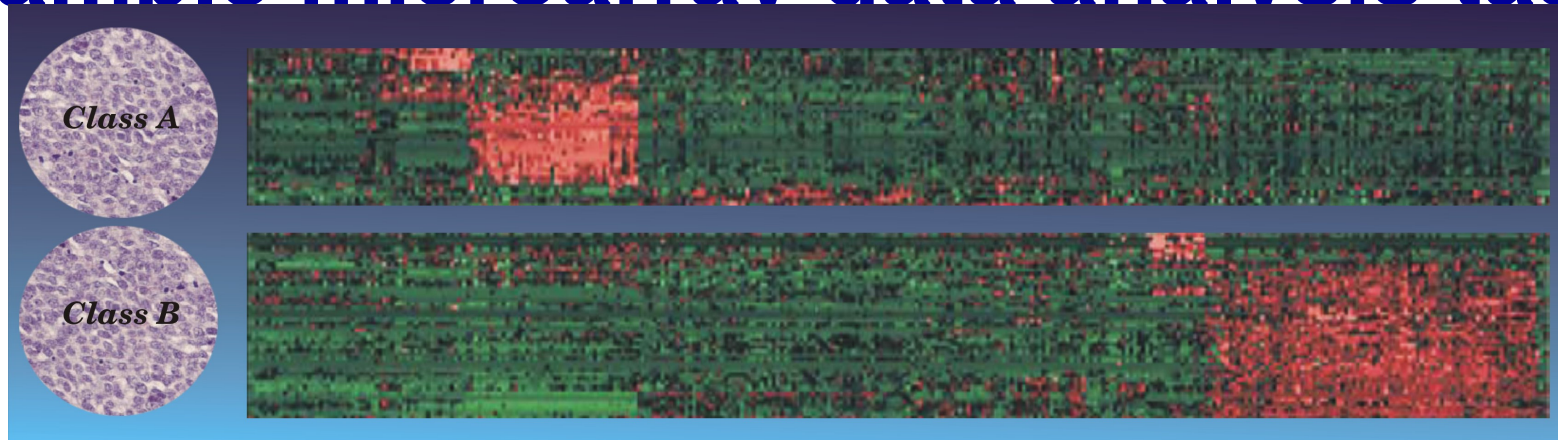

- Two-class diagnosis problem of distinguishing between acute lymphoblastic leukemia (ALL, 27 samples) and acute myeloid leukemia (AML, 11 samples), with 34 samples in the test set. Every sample is described with gene expression values for 7129 genes.
- Multi-class cancer diagnosis problem with 14 different cancer types, in total 144 samples in the training set and 54 samples in the test set. Every sample is described with gene expression values for 16063 genes.
- <http://www-genome.wi.mit.edu/cgi-bin/cancer/datasets.cgi>.

# Standard approach to identifying sets of differentially expressed genes and building a classification model (e.g. AML vs ALL)

109

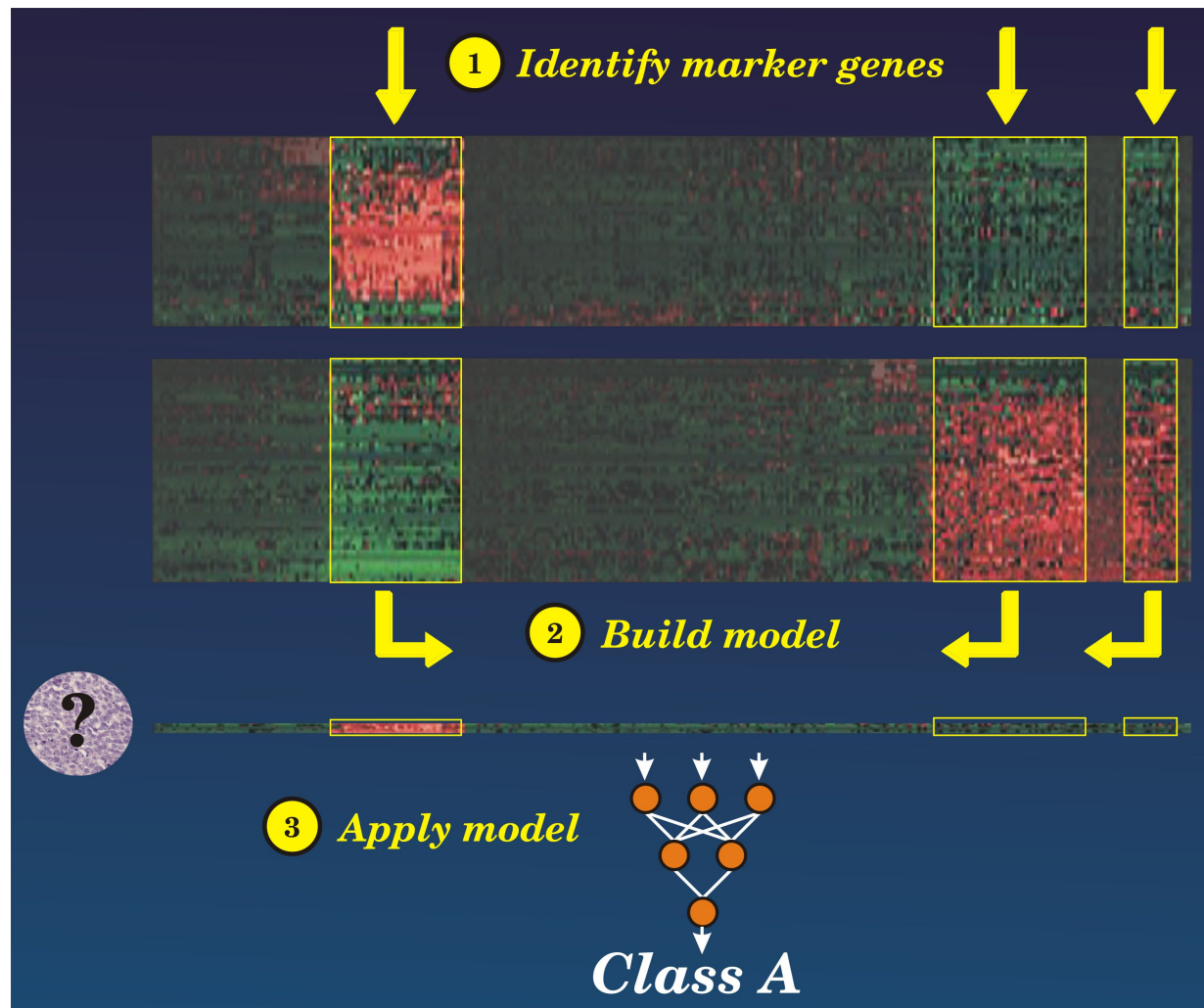

# Identifying sets of differentially expressed genes in preprocessing

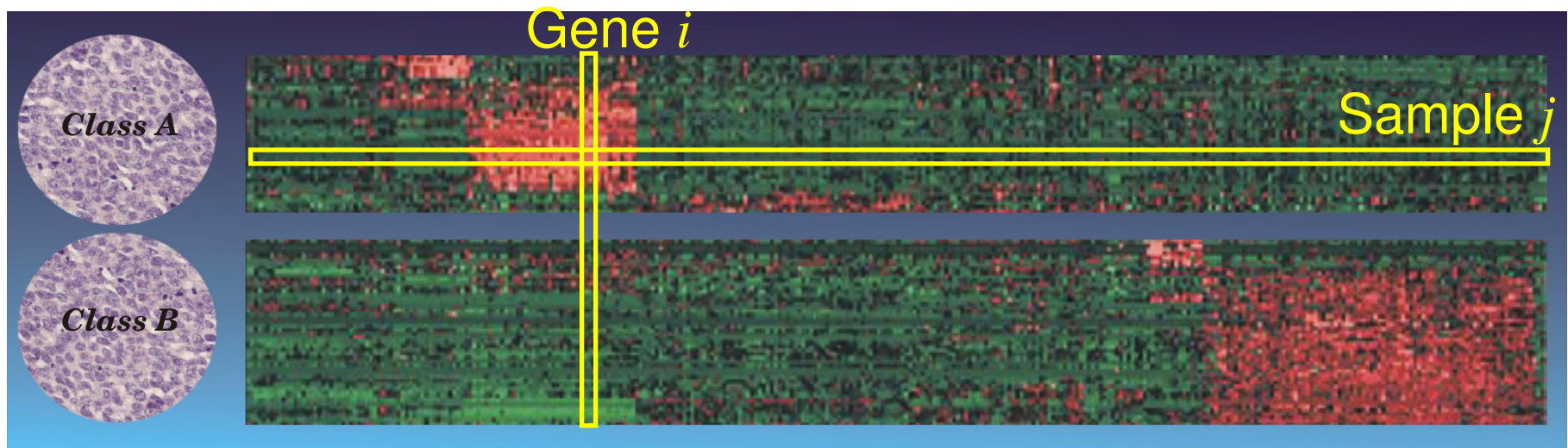

To identify genes that display a large difference in gene expression *between* groups (class A and class B) and are homogeneous *within* groups, statistical tests (e.g. t-test) and p-values (e.g. permutation test) are computed.

Two sample t–statistic is used to test the equality of group means  $m_A$  and  $m_B$ .

$$T_i = \frac{m_{iA} - m_{iB}}{\sqrt{\frac{s_{iA}^2}{n_A} + \frac{s_{iB}^2}{n_B}}}$$

# Ranking of differentially expressed genes

---

Gene	Score
$\text{gene}_{\sigma(1)}$	score 1
$\text{gene}_{\sigma(2)}$	score 2
$\text{gene}_{\sigma(3)}$	score 3
$\text{gene}_{\sigma(4)}$	score 4
.....	.....
$\text{gene}_{\sigma(100)}$	score 100
$\text{gene}_{\sigma(101)}$	score 101
.....	.....
$\text{gene}_{\sigma(9905)}$	score 9905

---

The genes can be ordered in a ranked **list L**, according to their differential expression between the classes.

The challenge is to extract **meaning** from this list, to describe them.

The terms of the **Gene Ontology** were used as a vocabulary for the description of the genes.

---

# Gene expression data (Prolog facts): Positive and negative examples for data mining

```
fact(class, geneID, weight).
```

```
fact('diffexp', 64499, 5.434).
```

```
fact('diffexp', 2534, 4.423).
```

```
fact('diffexp', 5199, 4.234).
```

```
fact('diffexp', 1052, 2.990).
```

```
fact('diffexp', 6036, 2.500).
```

```
...
```

```
...
```

```
fact('random', 7443, 1.0).
```

```
fact('random', 9221, 1.0).
```

```
fact('random', 23395, 1.0).
```

```
fact('random', 9657, 1.0).
```

```
fact('random', 19679, 1.0).
```

```
...
```

```
...
```



# Ontology encoded as relational background knowledge + gene expression data (Prolog facts)

## Prolog facts:

```
predicate(geneID, CONSTANT).  
interaction(geneID, geneID).
```

```
component(2532, 'GO:0016020').  
component(2532, 'GO:0005886').  
component(2534, 'GO:0008372').  
function(2534, 'GO:0030554').  
function(2534, 'GO:0005524').  
process(2534, 'GO:0007243').  
interaction(2534, 5155).  
interaction(2534, 4803).
```

Basic, plus generalized background knowledge using GO

zinc ion binding ->

metal ion binding, ion binding, binding

```
fact(class, geneID, weight).
```

```
fact('diffexp', 64499, 5.434).  
fact('diffexp', 2534, 4.423).  
fact('diffexp', 5199, 4.234).  
fact('diffexp', 1052, 2.990).  
fact('diffexp', 6036, 2.500).
```

...

...

```
fact('random', 7443, 1.0).  
fact('random', 9221, 1.0).  
fact('random', 23395, 1.0).  
fact('random', 9657, 1.0).  
fact('random', 19679, 1.0).
```

...

...

# Relational Subgroup Discovery with SEGS

- The SEGS (Searching for Enriched gene Sets) approach: Discovery of gene **subgroups** which
  - largely overlap with those associated by the classifier with a given class
  - can be compactly summarized in terms of their features
- What are **features**?
  - attributes of the original attributes (genes), and
  - recent work (SEGS): first-order features generated from GO, ENTREZ and KEGG

# SEGS: A RSD-like first-order feature construction approach

First order features with support  $> \textit{min\_support}$

f(7,A):-function(A,'GO:0046872').  
f(8,A):-function(A,'GO:0004871').  
f(11,A):-process(A,'GO:0007165').  
f(14,A):-process(A,'GO:0044267').  
f(15,A):-process(A,'GO:0050874').  
f(20,A):-function(A,'GO:0004871'), process(A,'GO:0050874').  
f(26,A):-component(A,'GO:0016021').  
f(29,A):- function(A,'GO:0046872'), component(A,'GO:0016020').  
f(122,A):-interaction(A,B),function(B,'GO:0004872').  
f(223,A):-interaction(A,B),function(B,'GO:0004871'),  
process(B,'GO:0009613').  
f(224,A):-interaction(A,B),function(B,'GO:0016787'),  
component(B,'GO:0043231').

existential



# Propositionalization

	f1	f2	f3	f4	f5	f6	...				...	fn
<b>g1</b>	1	0	0	1	1	1	0	0	1	0	1	1
<b>g2</b>	0	1	1	0	1	1	0	0	0	1	1	0
<b>g3</b>	0	1	1	1	0	0	1	1	0	0	0	1
<b>g4</b>	1	1	1	0	1	1	0	0	1	1	1	0
<b>g5</b>	1	1	1	0	0	1	0	1	1	0	1	0
<b>g1</b>	0	0	1	1	0	0	0	1	0	0	0	1
<b>g2</b>	1	1	0	0	1	1	0	1	0	1	1	1
<b>g3</b>	0	0	0	0	1	0	0	1	1	1	0	0
<b>g4</b>	1	0	1	1	1	0	1	0	0	1	0	1

# Propositional learning: subgroup discovery

	f1	f2	f3	f4	f5	f6	...				...	fn
<b>g1</b>	1	0	0	1	1	1	0	0	1	0	1	1
<b>g2</b>	0	1	1	0	1	1	0	0	0	1	1	0
<b>g3</b>	0	1	1	1	0	0	1	1	0	0	0	1
<b>g4</b>	1	1	1	0	1	1	0	0	1	1	1	0
<b>g5</b>	1	1	1	0	0	1	0	1	1	0	1	0
<b>g1</b>	0	0	1	1	0	0	0	1	0	0	0	1
<b>g2</b>	1	1	0	0	1	1	0	1	0	1	1	1
<b>g3</b>	0	0	0	0	1	0	0	1	1	1	0	0
<b>g4</b>	1	0	1	1	1	0	1	0	0	1	0	1

f2 and f3  
[4,0]

# Subgroup Discovery

diff. exp. genes

Not diff. exp. genes

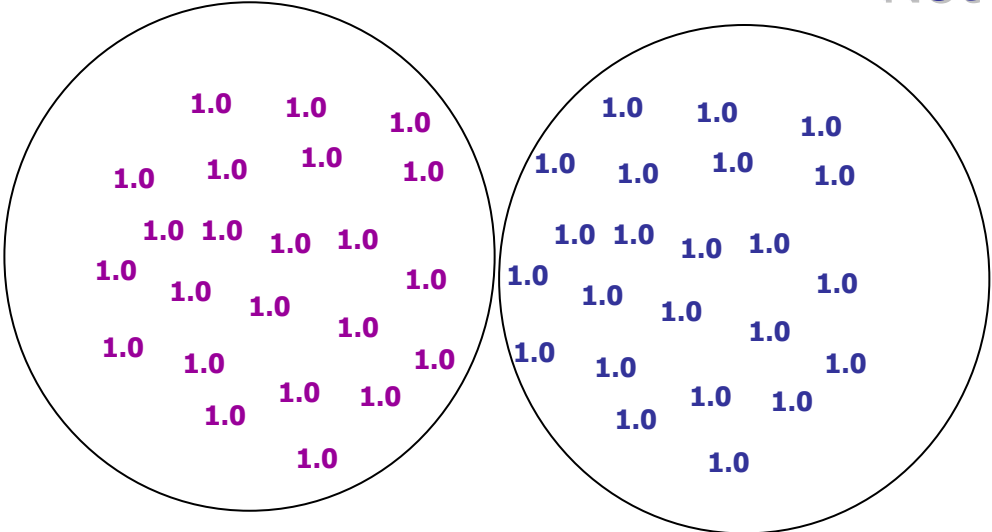

# Subgroup Discovery

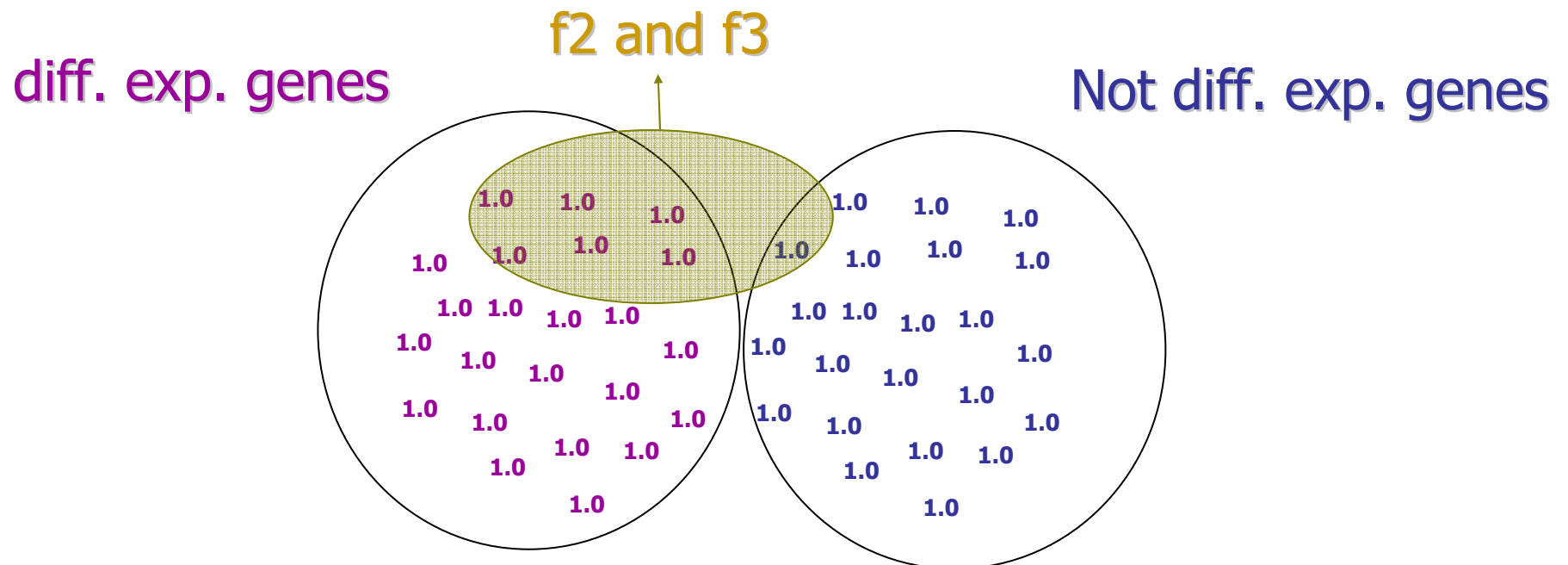

In RSD (using propositional learner CN2-SD):

Quality of the rules = Coverage x Precision

\*Coverage = sum of the covered weights

\*Precision = purity of the covered genes

# Subgroup Discovery

diff. exp. genes

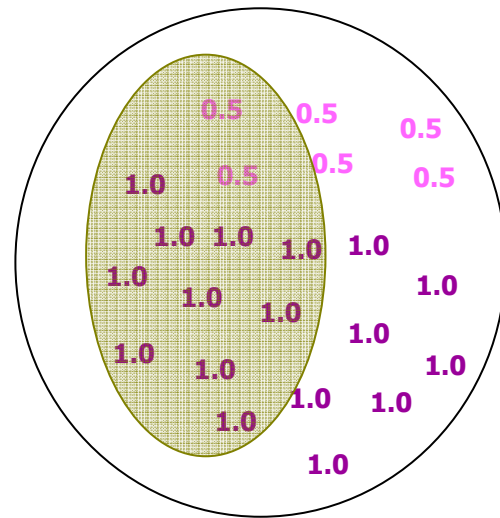

Not diff. exp. genes

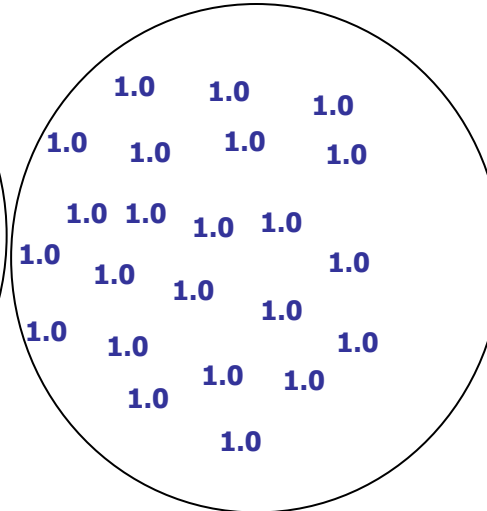

RSD naturally uses gene weights in its procedure for repetitive subgroup generation, via its heuristic rule evaluation: weighted relative accuracy



# Summary: SEGS, using the RSD approach

- **Constructs relational logic features** of genes such as  
**interaction(g, G) & function(G, protein\_binding)**  
*(g interacts with another gene whose functions include protein binding)*  
 Feature subject to constraints (undecomposability, minimum support, ...)
- Then SEGS **discovers subgroups** using these features that are differentially expressed (e.g., belong to class DIFFEXP of top 300 most differentially expressed genes) in contrast with RANDOM genes (randomly selected genes with low differential expression).
- Sample subgroup description:  
**diffexp(A) :- interaction(A,B) & function(B,'GO:0004871') & process(B,'GO:0009613')**

# Summary: SEGS, using the RSD approach

- The SEGS approach enables to discover new medical knowledge from the combination of gene expression data with public gene annotation databases
- In past 2-3 years, the SEGS approach proved effective in several biomedical applications (JBI 2008, ...)
  - The work on semantic data mining - using ontologies as background knowledge for subgroup discovery with SEGS - was done in collaboration with I. Trajkovski, F. Železny and J. Tolar

## **XX. Talk outline**

- Data mining in a nutshell revisited
- Subgroup discovery in a nutshell
- Relational data mining and propositionalization in a nutshell
- Semantic data mining: Using ontologies in SD

# Introductory seminar lecture

## X. JSI & Knowledge Technologies

### I. Introduction

- Data Mining and KDD process
- DM standards, tools and visualization
- Classification of Data Mining techniques: Predictive and descriptive DM

(Mladenić et al. Ch. 1 and 11, Kononenko & Kukar Ch. 1)

### XX. Selected data mining techniques: Advanced subgroup discovery techniques and applications

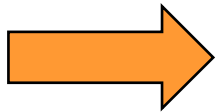

### XXX. Recent advances: Cross-context link discovery

# The BISON project

- EU project: Bisociation networks for creative information discovery ([www.bisonet.eu](http://www.bisonet.eu)), 2008-2010
- Exploring the idea of bisociation (Arthur Koestler, The act of creation, 1964):
  - The mixture - in one human mind – of **two different contexts** or **different categories of objects**, that are normally considered **separate categories** by the processes of the mind.
  - The **thinking process** that is the functional basis of **analogical or metaphoric thinking** as compared to logical or associative thinking.
- Main challenge: Support humans to find **new interesting associations across domains**

# Bisociation (A. Koestler 1964)

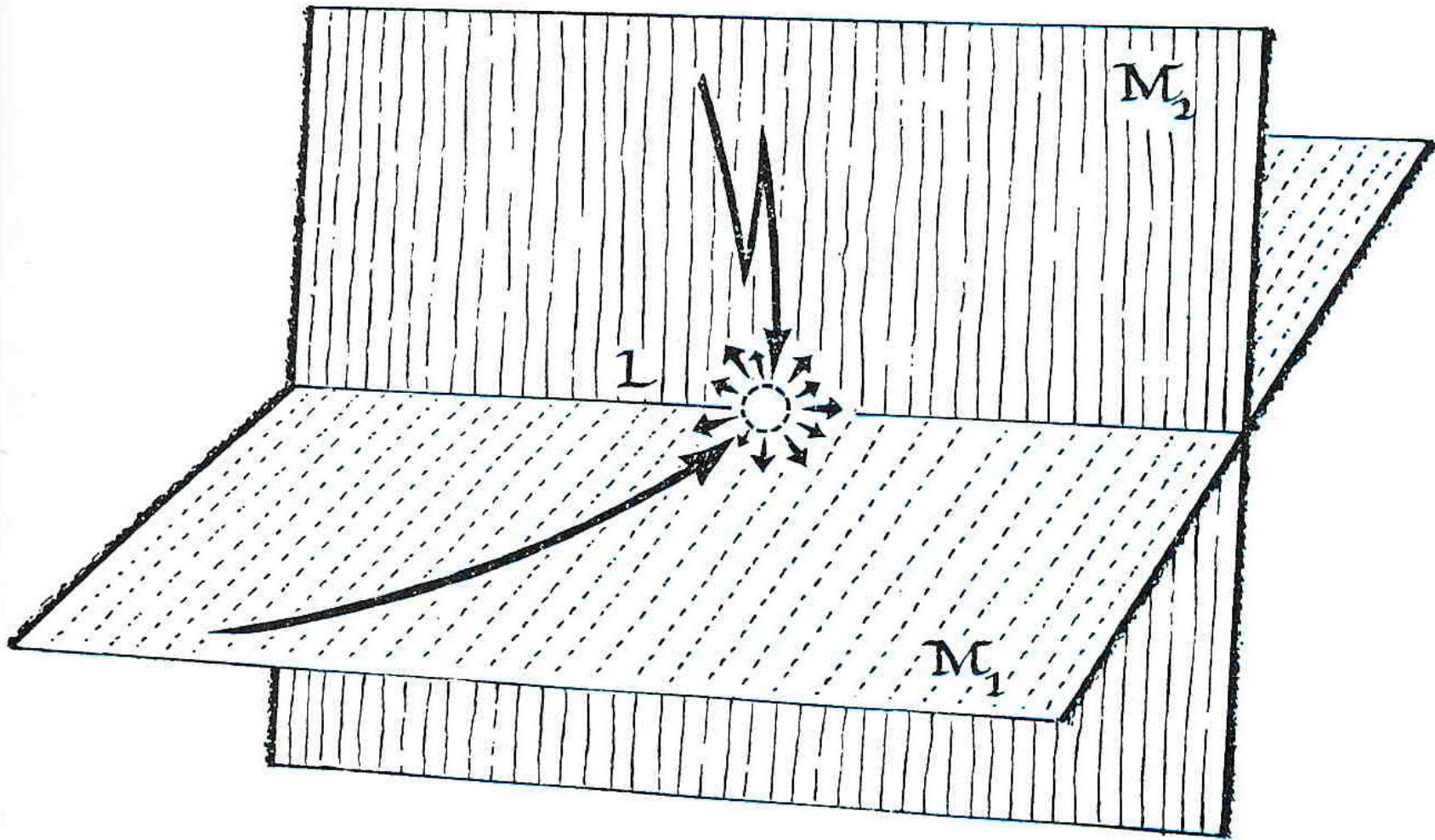

# The BISON project

- BISON challenge: Support humans to find **new, interesting links across domains**, named **bisociations**
  - across different contexts
  - across different types of data and knowledge sources
- Open problems:
  - Fusion of heterogeneous data/knowledge sources into a joint representation format - a large information network named BisoNet (consisting of nodes and relationships between nodes)
  - Finding unexpected, previously unknown links between BisoNet nodes belonging to different contexts

# Heterogeneous data sources (BISON, M. Berthold, 2008)

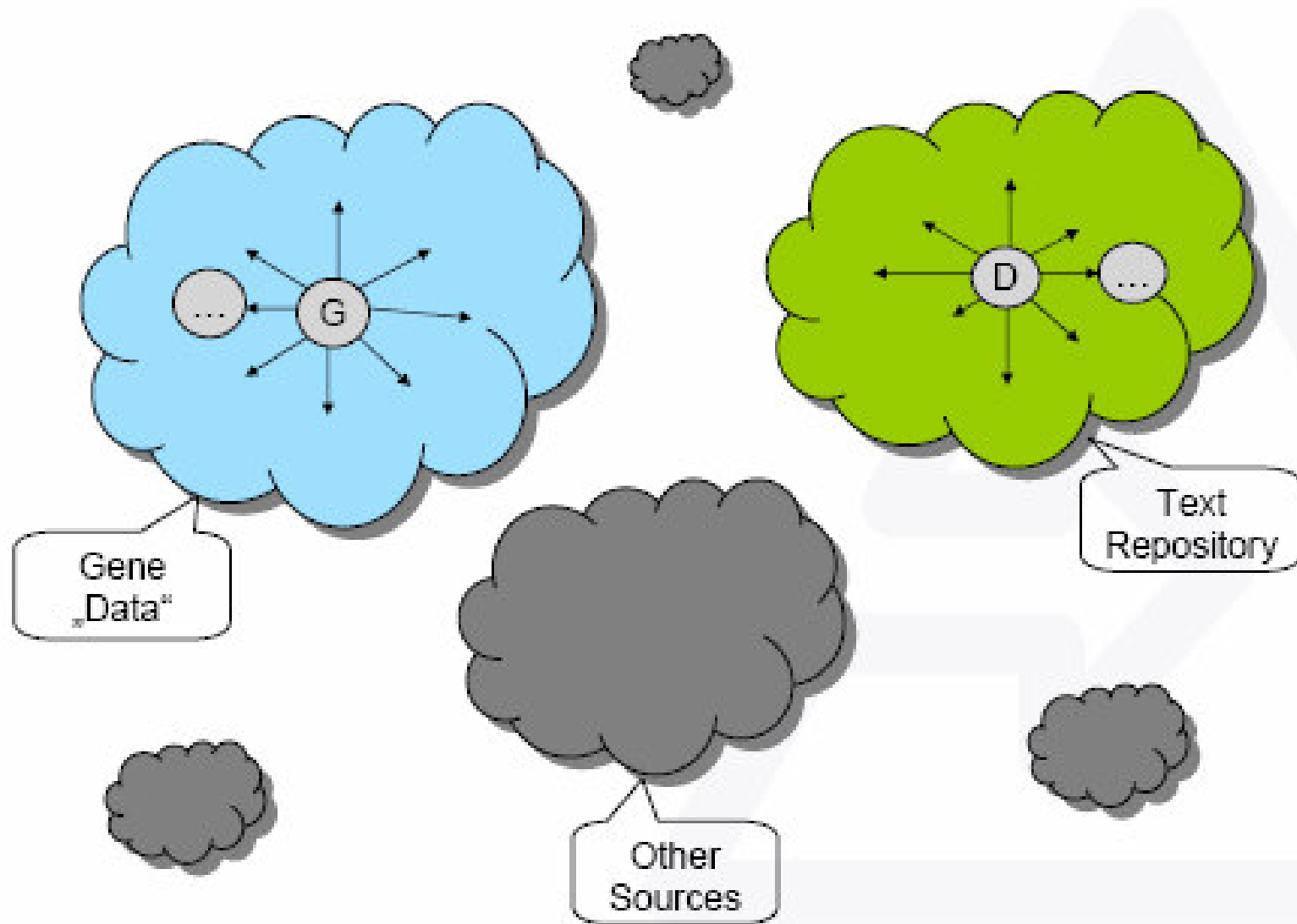



# Bridging concepts (BISON, M. Berthold, 2008)

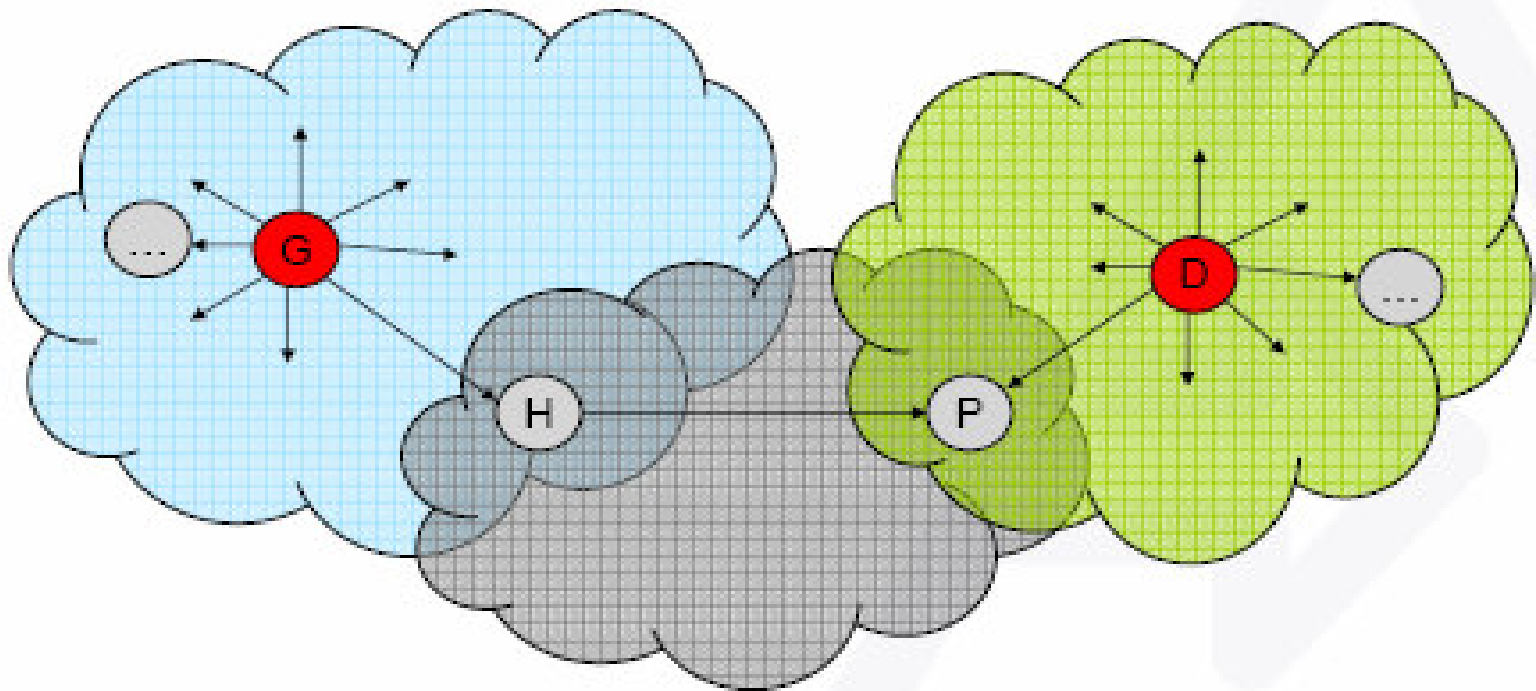

# Chains of associations across domains (BISON, M. Berthold, 2008)

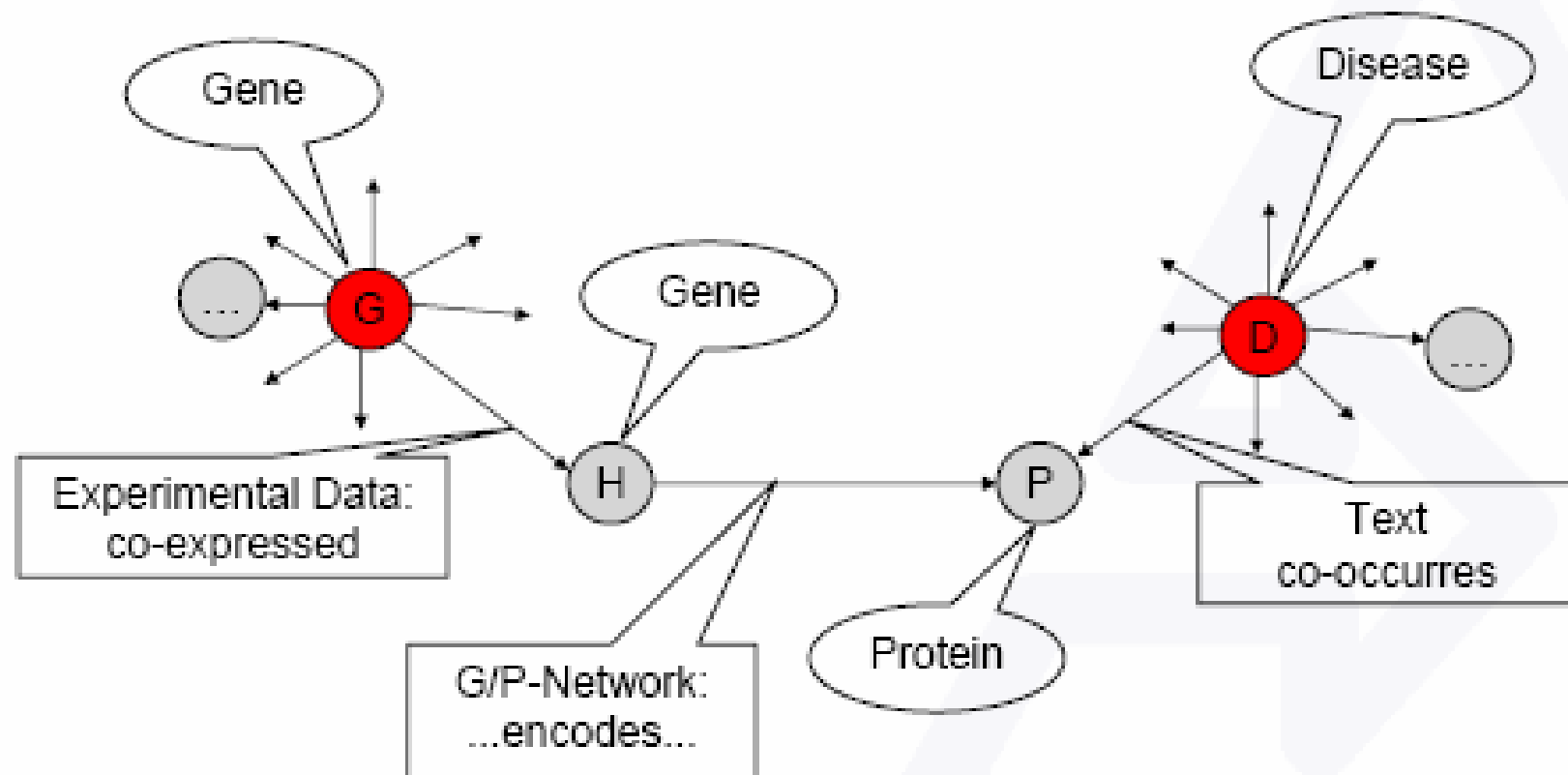

# Bisociative link discovery with SEGS and Biomine

- Application: Glioma cancer treatment
- Approach: SEGS+Biomine
  - Analysis of microarray data
  - SEGS: Find groups of genes
  - Biomine: Find cross-context links in biomedical databases
- Recent work in creative knowledge discovery (in BISON) is performed in collaboration with
  - JSI team: P. Kralj Novak, I. Mozetič, M. Juršič and V. Podpečan
  - UH team: H. Toivonen from UH

# SEGS+Biomine approach

Microarray

```
gene1: + +
gene2: +
gene3: +
...
geneN: - -
```

SEGS

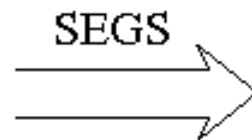

Gene sets

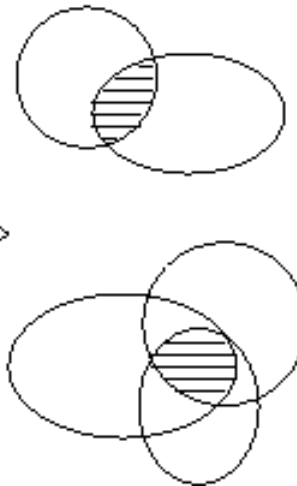

Biomine

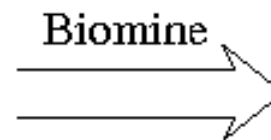

Exploratory  
link discovery

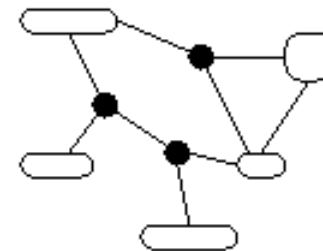

e.g. slow-vs-fast  
cell growth

# SEGS: BisoNet node identification

## Query:

SEGS -- Descriptive Microarray Data Analysis - Mozilla Firefox

File Edit View History Bookmarks Tools Help

http://kt.ijs.si/software/SEGS/index.php?show=tool

Most Visited Petra's Home Page

mands ... SEGS ... Microarray ... Gene set en ... Biomine proj ... Tulp Softwa ... Tulp Softwa ...

## SEGS

Main page  
Publications  
Web tool

Downloads

- GO & KEGG
- Gene annotations
- Gene interactions
- Gene expression data

Authors

- Igor Trajkovski
- Nada Lavrac

Project Name:  (optional)

Annotation data:

- Molecular Functions
- Biological Processes
- Cellular Components
- KEGG Orthology
- Gene interactions

Constraints:

Number of DE genes:

Minimal set size:  (min=20)

Output:

Maximal p-value:

Combine p-values: Fisher  GSEA  PAGE

Report top  most enriched gene sets.

Summarize descriptions

Upload:

input file:

DEPARTMENT OF KNOWLEDGE TECHNOLOGIES  
Jožef Stefan Institute

Find:      Match case

Done

## Results:

Mozilla Firefox

File Edit View History Bookmarks Tools Help

http://kt.ijs.si/software/SEGS/work\_dir/phprRlvFW.0.all.ht

Most Visited Petra's Home Page

mands ... htt...tml ... Microarray ... Gene set en ... Biomine proj ... Tulp Softwa ... Tulp Softwa ...

Project: []

Enriched genesets for class A

found by Combining p-values

#	Description	Set size	#DE_Genes	Fisher p-value (unadjusted p-value)	GSEA p-value (Enricment score)	PAGE p-value (Z-score)	Agregate p-value
1	Func(monovalent inorganic cation transporter activity), Proc(monovalent inorganic cation transport),	26	10	0.000 (9.20e-07)	0.010 (0.362)	0.020 (3.767)	0.010
2	Func(monovalent inorganic cation transporter activity), Proc(monovalent inorganic cation transport), Comp(integral to membrane),	24	9	0.010 (4.23e-06)	0.010 (0.352)	0.020 (3.671)	0.013
3	Func(monovalent inorganic cation transporter activity), Proc(transport), Comp(integral to membrane),	26	9	0.010 (9.10e-06)	0.040 (0.323)	0.020 (3.801)	0.023

Find:      Match case

Done

# Gene Analytics

Main page

Publications

Web tool

## Downloads

- [GO & KEGG](#)
- [Gene annotations](#)
- [Gene interactions](#)
- [Gene expression data](#)

## Authors

- [Igor Trajkovski](#)
- [Nada Lavrac](#)
- [Vid Podpecan](#)

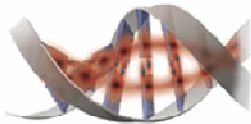

## Project Name:

(optional)

## Upload:

microarray data file (csv format):

- only over-expressed genes ( $\log_{FC} \geq 0$ )  
 only under-expressed genes ( $\log_{FC} < 0$ ) (absolute values are taken)  
 all genes  
 do not use genes with absolute  $\log_{FC}$  value lower than:

## SEGS input:

- Relief ranks  
  $\log_{FC}$  values  
 do not use genes with Relief rank lower than:

## Annotation data:

- Molecular Functions  
 Biological Processes  
 Cellular Components  
 KEGG Orthology  
 Gene interactions

## Constraints:

Number of DE genes:

Minimal set size:  (min=20)

## Output:

Maximal p-value:

Combine p-values: Fisher  GSEA  PAGE

Report top  most enriched gene sets.

- Summarize descriptions  
 Enable repeatability  
 random generator seed:

**Note:** by using the same number you can repeat your experiment!

## **Biomine (University of Helsinki)**

- The Biomine project develops methods for the analysis of biological databases that contain large amounts of rich data:
  - annotated sequences,
  - proteins,
  - orthology groups,
  - genes and gene expressions,
  - gene and protein interactions,
  - PubMed articles,
  - ontologies.

# Biological databases used in Biomine

Vertex type	Source database	Number of vertices	Mean degree
Article	PubMed	330970	6.92
Biological process	GOA	10744	6.76
Cellular component	GOA	1807	16.21
Conserved domain	Entrez Domains	15727	99.82
Gene Entrez	Gene	395611	6.09
Gene cluster	UniGene	362155	2.36
Homology group	HomoloGene	35478	14.68
Molecular function	GOA	7922	7.28
OMIM entry	OMIM	15253	34.35
Protein Entrez	Protein	741856	5.36
Structural property	Entrez Structure	26425	3.33



# Biomine graph exploration

- Given:
  - nodes (~1 mio) correspond to different concepts (such as gene, protein, domain, phenotype, biological process, tissue)
  - semantically labeled edges (~7 mio) connect related concepts
- Answer queries:
  - Discover links between entities in queries by sophisticated graph exploration algorithms

# Biomine: Bisociative link discovery

## Query:

## Result:

Biomine search - Mozilla Firefox

File Edit View History Bookmarks Tools Help

http://biomine.cs.helsinki.fi/search/

Most Visited Petra's Home Page

Microarray... Gene set en... Biomine proj... Tulip Softwa... Tulip Softwa... Biomi...

## BIOMINE

[Help](#) [About Biomine](#)

GO: GO: 0015077 GO: GO: 0015672

Search

Find: garr Next Previous Highlight all Match case

Done

Biomine search results - BMVis - Mozilla Firefox

File Edit View History Bookmarks Tools Help

http://biomine.cs.helsinki.fi/search/bmvis.cgi?file=searche

Most Visited Petra's Home Page

barry... Gene set en... Biomine proj... Tulip Softwa... Tulip Softwa... Biomine sea... Biomi...

### Nodes View

Find: garr Next Previous Highlight all Match case

Applet biomine.bmvis.BMVis started

# Summary

- SEGS discovers interesting gene group descriptions as conjunctions of concepts (possibly from different contexts/ontologies)
- Biomine finds cross-context links (paths) between concepts discovered by SEGS
- The SEGS+Biomine approach has the potential for creative knowledge and bisociative link discovery
- Preliminary results in stem cell microarray data analysis (EMBC 2009, ICCC Computational Creativity 2010) indicate that the SEGS+Biomine methodology may lead to new insights – in vitro experiments will be planned at NIB to verify and validate the preliminary insights

# Cross-context link discovery in Text Mining, Web Mining and Social Network Analysis: First attempts

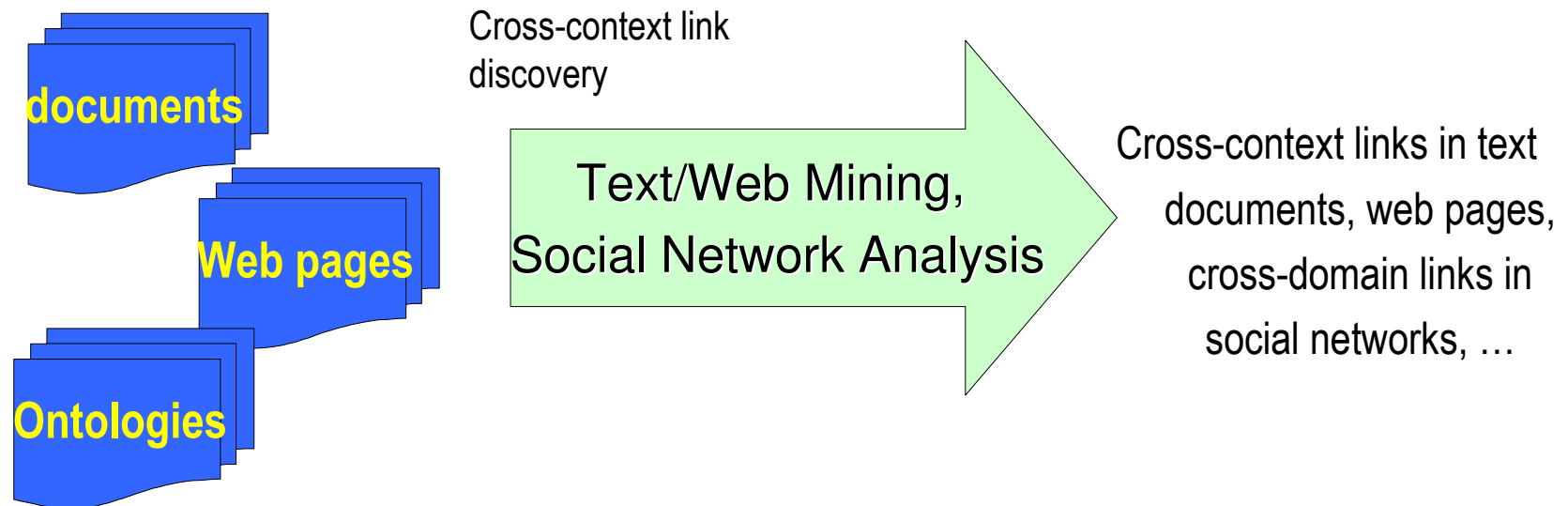

Goal of the rest of these slides:

Establish a **Cross-context link** 😊

with lectures on text mining and semantic web by Dunja Mladenić

# OntoSight & OntoGen Demo

- **OntoSight**
  - Application that helps the user decide which data to include into the process and how to set the weights,
  - developed by Miha Grčar
- **OntoGen**
  - A system for *data-driven semi-automatic* ontology construction
  - Developed by Blaž Fortuna, Marko Grobelnik, Dunja Mladenić

# OntoSight

- **Visualization**
  - Networks
  - Semantic spaces
- **Interaction** with the user
- Helps the user decide which data to include into the process and how to set the weights

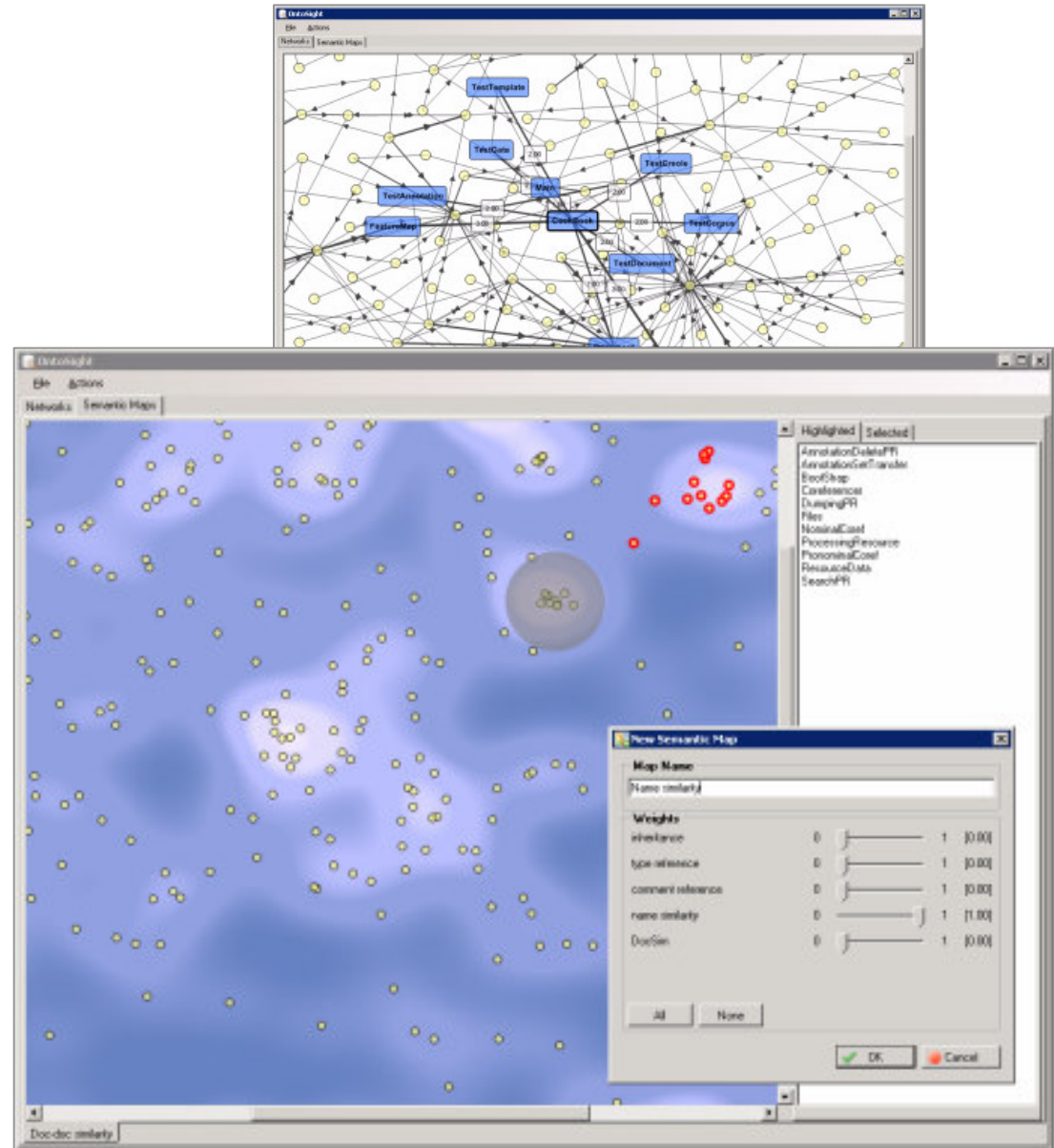

# Contextualisation in Text Mining: Context creation through OntoGen

- OntoGen: A system for *data-driven semi-automated* ontology construction from text documents
  - Semi-automatic: it is an interactive tool that aids the user
  - Data-driven: aid provided by the system is based on some underlying data provided by the user
- SEKT technology (<http://sekt-project.org>)
- Freely available at <http://ontogen.ijs.si>

**OntoGen -- Text Garden**

File About

### Concepts

New Move Delete

- [-] annotation, event, document
  - [-] map, features, gazetteer
  - [-] annotation, gate, corpus
  - [-] document, resource, data
- [-] exception, impl, words
  - [-] exception, methods, exception\_exception
  - [-] impl, wrapper, rules
  - [-] words, net, words\_net
- [-] test, indexed, property
  - [-] test, test\_class, pr
  - [-] indexed, property, files

### Ontology details

**Ontology visualization** Concept's documents Concept Visualization

Concept font size:  Relation font size:

### Concept properties

**Details** Suggestions Relations

Id:  Name:

Keywords:

SVM Keywords:

All documents:

Unused documents:



# Contextualisation in Text Mining: OntoGen context visualisation with DocumentAtlas

145

- Context visualisation in OntoGen using DocumentAtlas
  - Use as aid to the user in choosing document clusters forming ontology (sub)concepts
  - Use as means for domain understanding via visualisation

**OntoGen -- Text Garden**

File About

### Concepts

New Move Delete

- root
  - annotation, event, document
  - exception, impl, words
  - test, indexed, property

### Concept properties

Details **Suggestions** Relations

Suggest k-Means Query Add

No. suggestions: 3 Docs:  All  Unused

Keywords No. ... [%]

Keywords	No. ...	[%]

### Ontology details

**Ontology visualization** Concept's documents **Concept Visualization**

Map properties Zoom mode **Select mode**

OntoGen news: [OntoGen won Best Demo Award at ESWC 2006](#)

# Contextualisation in Text Mining: Contextualised search

147

- Google search is sophisticated but not smart

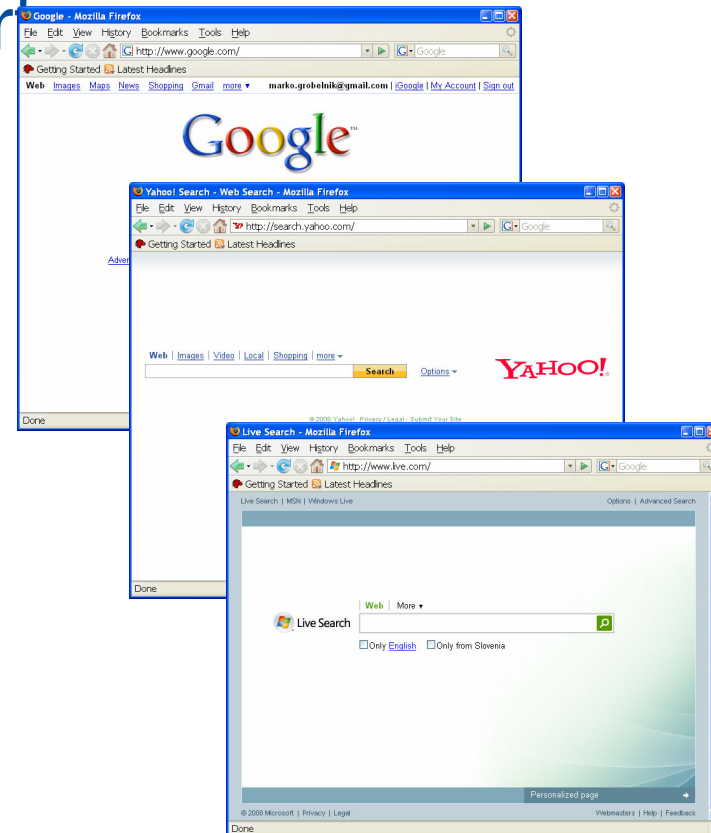

# Example – Searching for “jaguar”

- Google search is sophisticated but not smart
- E.g., query “jaguar” has many meanings...
- ...but the first page of search engines doesn't provide us with many answers
- ...there are 84M more results

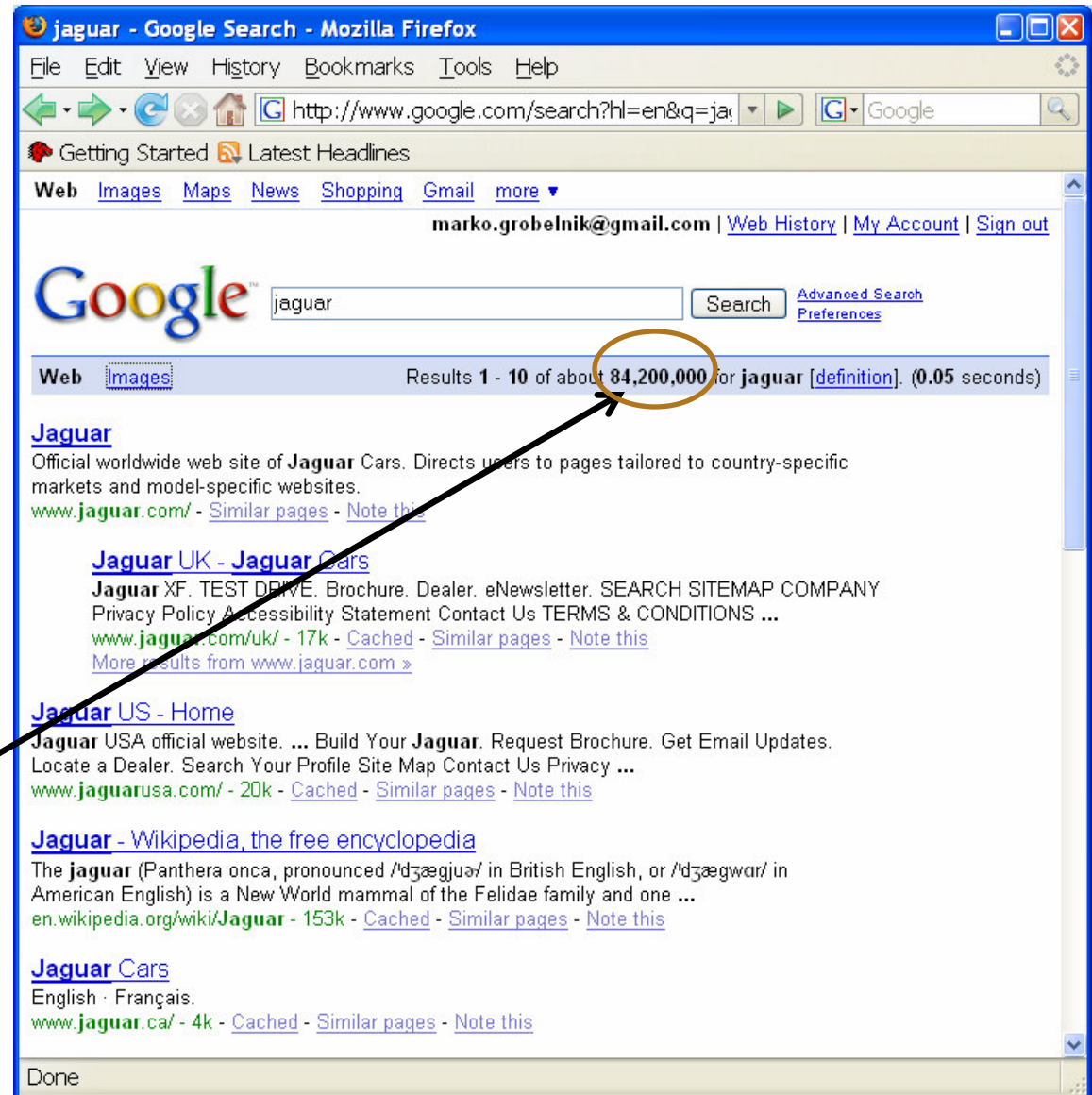

# Context sensitive search with

# http://searchpoint.ijs.si

Developed by  
Bostjan  
Pajntar and  
Marko  
Grobelnik

Query  
Conceptual map  
Search Point  
Dynamic contextual ranking based on the search point

The screenshot shows a Windows Internet Explorer browser window titled "jaguar - SearchPoint - Windows Internet Explorer". The address bar displays "http://searchpoint.ijs.si/Result.aspx". The search bar contains the query "jaguar". Below the search bar are three buttons: "Search via topics", "Search via query to ontology", and "Search via hits to ontology". The search results list includes:

- (9) [Jaguar](#)  
General information and facts from Big Cats Online.  
<http://www.abf90.dial.pipex.com/jaguar.htm>
- (59) [Jaguar, Jaguar Profile, Facts, Information, Photos, Pictures ...](#)  
Get jaguar profile, facts, information, photos, pictures, sounds, habitats, reports, news, and more from National Geographic.  
<http://animals.nationalgeographic.com/animals/mammals/jaguar.html>
- (6) [Jaguar - Wikipedia, the free encyclopedia](#)  
The jaguar (*Panthera onca*) is a New World mammal of the Felidae family and one of four "big cats" in the Panthera genus, along with the tiger ...  
<http://en.wikipedia.org/wiki/Jaguar>
- (11) [Jaguar](#)  
Jaguar Facts, Jaguar Photos and Jaguars in the news at the world's largest big cat rescue and sanctuary.  
<http://www.bigcatrescue.org/jaguar.htm>
- (1) [Jaguar](#)  
Official worldwide web site of Jaguar Cars. Directs users to pages tailored to country-specific markets.  
<http://www.jaguar.com/>
- (32) [Jaguar](#)  
Contains extensive information about the Jaguar. Information includes habitat, body size, and life span.  
<http://www.abf90.dial.pipex.com/bco/jaguar.htm>
- (2) [Jaguar UK - Jaguar Cars](#)  
Jaguar & Ownership. Highlights. Gallery. Models & Pricing. Design Your XK. TEST DRIVE. Brochure. Dealer. eNewsletter ...  
<http://www.jaguar.co.uk/>
- (17) [Jaguar Enthusiasts' Club](#)  
World's largest audited membership. UK-based, JEC's site has extensive resources available for the enthusiast, including information about their Sections, ...  
<http://www.jec.org.uk/>
- (20) [San Diego Zoo's Animal Bytes: Jaguar](#)  
Get fun and interesting jaguar facts in an easy-to-read style from the San Diego Zoo's Animal

On the right side of the browser window, there is a conceptual map. The map is a network of nodes connected by lines. The nodes include: "Parts and Accessories", "Mammalia", "Vehicles", "Shopping", "Recreation", "Society", "Aircraft", "Aviation", "Games", "Console Platforms", "Sports", "NFL", and "Dance". A red dot is placed on the "Dance" node, and a black arrow points from the search results area towards it.

# Introductory seminar lecture: Summary

- **JSI & Knowledge Technologies**
- **Introduction to Data mining and KDD**
  - Data Mining and KDD process
  - DM standards, tools and visualization
  - Classification of Data Mining techniques: Predictive and descriptive DM
- **Selected data mining techniques:  
Advanced subgroup discovery techniques  
and applications**
- **Recent advances: Cross-context link  
discovery**

## Part II. Predictive DM techniques

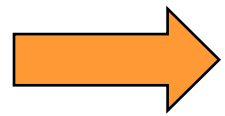

- Naive Bayesian classifier
- Decision tree learning
- Classification rule learning
- Classifier evaluation

# Bayesian methods

- Bayesian methods – simple but powerful classification methods
  - Based on Bayesian formula

$$p(H | D) = \frac{p(D | H)}{p(D)} p(H)$$

- Main methods:
  - Naive Bayesian classifier
  - Semi-naïve Bayesian classifier
  - Bayesian networks \*

\* Out of scope of this course



# Naïve Bayesian classifier

- Probability of class, for given attribute values

$$p(c_j | v_1 \dots v_n) = p(c_j) \cdot \frac{p(v_1 \dots v_n | c_j)}{p(v_1 \dots v_n)}$$

- For all  $C_j$  compute probability  $p(C_j)$ , given values  $v_i$  of all attributes describing the example which we want to classify (assumption: conditional independence of attributes, when estimating  $p(C_j)$  and  $p(C_j | v_i)$ )

$$p(c_j | v_1 \dots v_n) \approx p(c_j) \cdot \prod_i \frac{p(c_j | v_i)}{p(c_j)}$$

- Output  $C_{MAX}$  with maximal posterior probability of class:

$$C_{MAX} = \arg \max_{c_j} p(c_j | v_1 \dots v_n)$$

# Naïve Bayesian classifier

$$\begin{aligned}
 p(c_j | v_1 \dots v_n) &= \frac{p(c_j \cdot v_1 \dots v_n)}{p(v_1 \dots v_n)} = \frac{p(v_1 \dots v_n | c_j) \cdot p(c_j)}{p(v_1 \dots v_n)} = \\
 &= \frac{\prod_i p(v_i | c_j) \cdot p(c_j)}{p(v_1 \dots v_n)} = \frac{p(c_j)}{p(v_1 \dots v_n)} \prod_i \frac{p(c_j | v_i) \cdot p(v_i)}{p(c_j)} = \\
 &= p(c_j) \cdot \frac{\prod_i p(v_i)}{p(v_1 \dots v_n)} \prod_i \frac{p(c_j | v_i)}{p(c_j)} \approx p(c_j) \cdot \prod_i \frac{p(c_j | v_i)}{p(c_j)}
 \end{aligned}$$

# Semi-naïve Bayesian classifier

- Naive Bayesian estimation of probabilities (reliable)

$$\frac{p(c_j | v_i)}{p(c_j)} \cdot \frac{p(c_j | v_k)}{p(c_j)}$$

- Semi-naïve Bayesian estimation of probabilities (less reliable)

$$\frac{p(c_j | v_i, v_k)}{p(c_j)}$$

# Probability estimation

- Relative frequency:

$$p(c_j) = \frac{n(c_j)}{N}, p(c_j | v_i) = \frac{n(c_j, v_i)}{n(v_i)} \quad j = 1..k, \text{ for } k \text{ classes}$$

- Prior probability: Laplace law

$$p(c_j) = \frac{n(c_j) + 1}{N + k}$$

- m-estimate:

$$p(c_j) = \frac{n(c_j) + m \cdot p_a(c_j)}{N + m}$$

# Probability estimation: intuition

- Experiment with  $N$  trials,  $n$  successful
- Estimate probability of success of next trial
- **Relative frequency:  $n/N$** 
  - reliable estimate when number of trials is large
  - Unreliable when number of trials is small, e.g.,  $1/1=1$
- **Laplace:  $(n+1)/(N+2)$ ,  $(n+1)/(N+k)$ ,  $k$  classes**
  - Assumes uniform distribution of classes
- **$m$ -estimate:  $(n+m.p_a)/(N+m)$** 
  - Prior probability of success  $p_a$ , parameter  $m$  (weight of prior probability, i.e., number of ‘virtual’ examples )

# Explanation of Bayesian classifier

- Based on information theory
  - Expected number of bits needed to encode a message = optimal code length  $-\log p$  for a message, whose probability is  $p$  (\*)
- Explanation based on the sum of information gains of individual attribute values  $v_i$  (Kononenko and Bratko 1991, Kononenko 1993)

$$\begin{aligned} -\log(p(c_j | v_1 \dots v_n)) &= \\ &= -\log(p(c_j)) - \sum_{i=1}^n (-\log p(c_j) + \log(p(c_j | v_i))) \end{aligned}$$

\*  $\log p$  denotes binary logarithm

# Example of explanation of semi-naïve Bayesian classifier

Hip surgery prognosis

Class = no (“no complications”, most probable class, 2 class problem)

Attribute value	For decision (bit)	Against (bit)
Age = 70-80	0.07	
Sex = Female		-0.19
Mobility before injury = Fully mobile	0.04	
State of health before injury = Other	0.52	
Mechanism of injury = Simple fall		-0.08
Additional injuries = None	0	
Time between injury and operation > 10 days	0.42	
Fracture classification acc. To Garden = Garden III		-0.3
Fracture classification acc. To Pauwels = Pauwels III		-0.14
Transfusion = Yes	0.07	
Antibiotic profilaxies = Yes		-0.32
Hospital rehabilitation = Yes	0.05	
General complications = None		0
<b>Combination:</b>	0.21	
Time between injury and examination < 6 hours AND Hospitalization time between 4 and 5 weeks		
<b>Combination:</b>	0.63	
Therapy = Arthroplastic AND anticoagulant therapy = Yes		

# Visualization of information gains for/against $C_i$

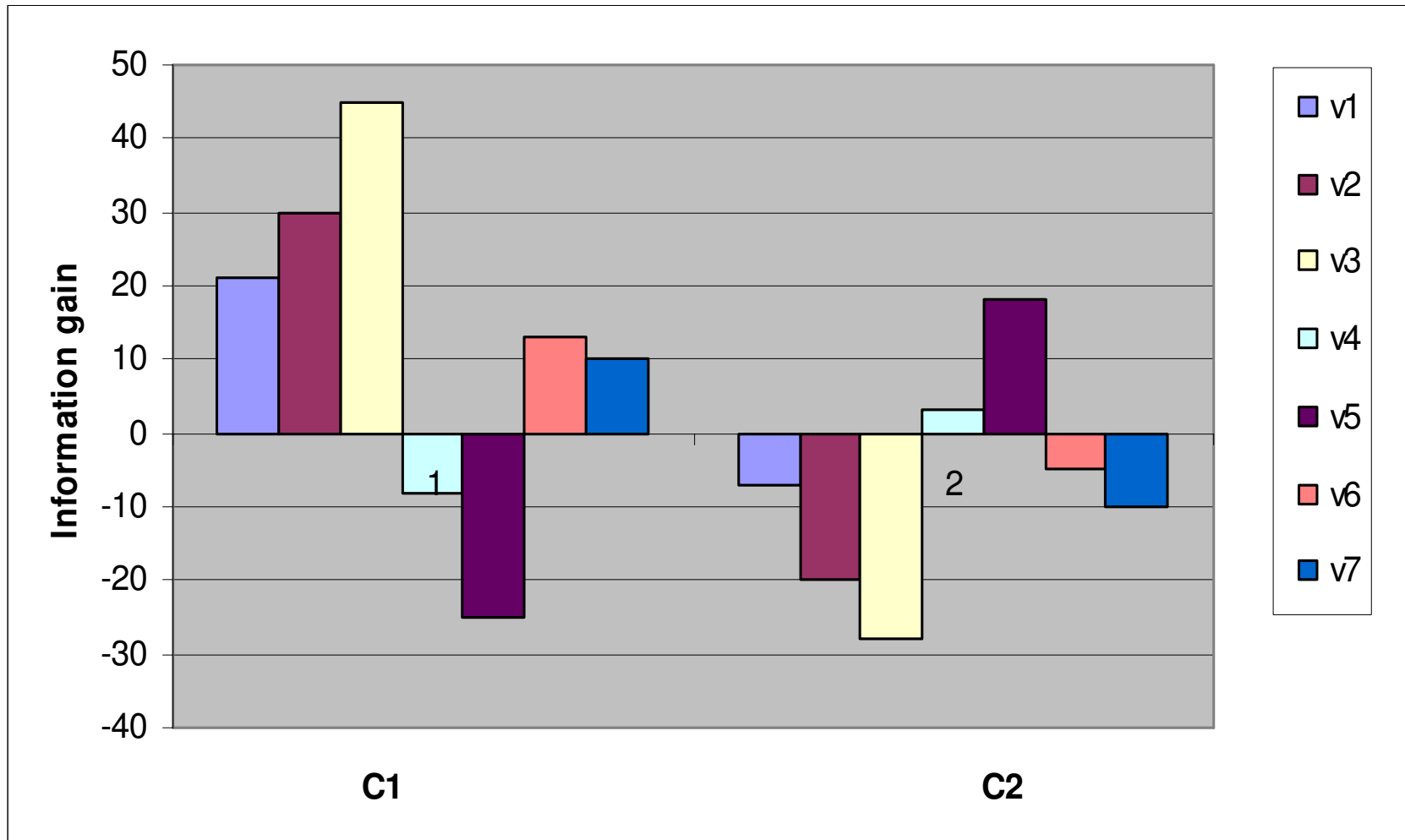



# Naïve Bayesian classifier

- Naïve Bayesian classifier can be used
  - when we have sufficient number of training examples for reliable probability estimation
- It achieves good classification accuracy
  - can be used as ‘gold standard’ for comparison with other classifiers
- Resistant to noise (errors)
  - Reliable probability estimation
  - Uses all available information
- Successful in many application domains
  - Web page and document classification
  - Medical diagnosis and prognosis, ...

# Improved classification accuracy due to using m-estimate

	Primary tumor	Breast cancer	thyroid	Rheumatology
#instan	339	288	884	355
#class	22	2	4	6
#attrib	17	10	15	32
#values	2	2.7	9.1	9.1
majority	25%	80%	56%	66%
entropy	3.64	0.72	1.59	1.7

	Relative freq.	m-estimate
Primary tumor	48.20%	52.50%
Breast cancer	77.40%	79.70%
hepatitis	58.40%	90.00%
lymphography	79.70%	87.70%

## Part II. Predictive DM techniques

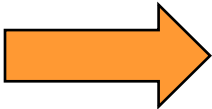
- Naïve Bayesian classifier
-  • Decision tree learning
- Classification rule learning
- Classifier evaluation

# Illustrative example: Contact lenses data

Person	Age	Spect. presc.	Astigm.	Tear prod.	Lenses
O1	young	myope	no	reduced	NONE
O2	young	myope	no	normal	SOFT
O3	young	myope	yes	reduced	NONE
O4	young	myope	yes	normal	HARD
O5	young	hypermetrope	no	reduced	NONE
O6-O13	...	...	...	...	...
O14	pre-presbyc	hypermetrope	no	normal	SOFT
O15	pre-presbyc	hypermetrope	yes	reduced	NONE
O16	pre-presbyc	hypermetrope	yes	normal	NONE
O17	presbyopic	myope	no	reduced	NONE
O18	presbyopic	myope	no	normal	NONE
O19-O23	...	...	...	...	...
O24	presbyopic	hypermetrope	yes	normal	NONE

# Decision tree for contact lenses recommendation

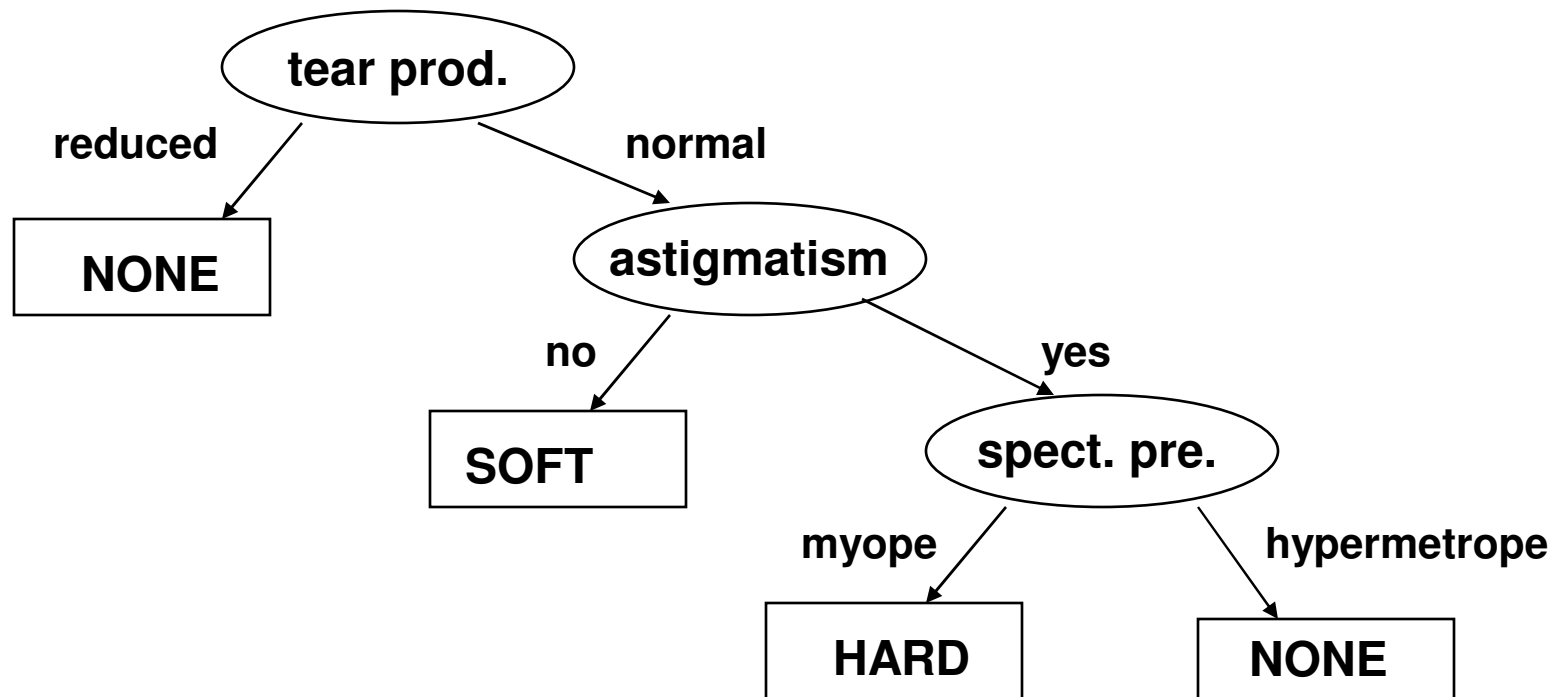

# Decision tree for contact lenses recommendation

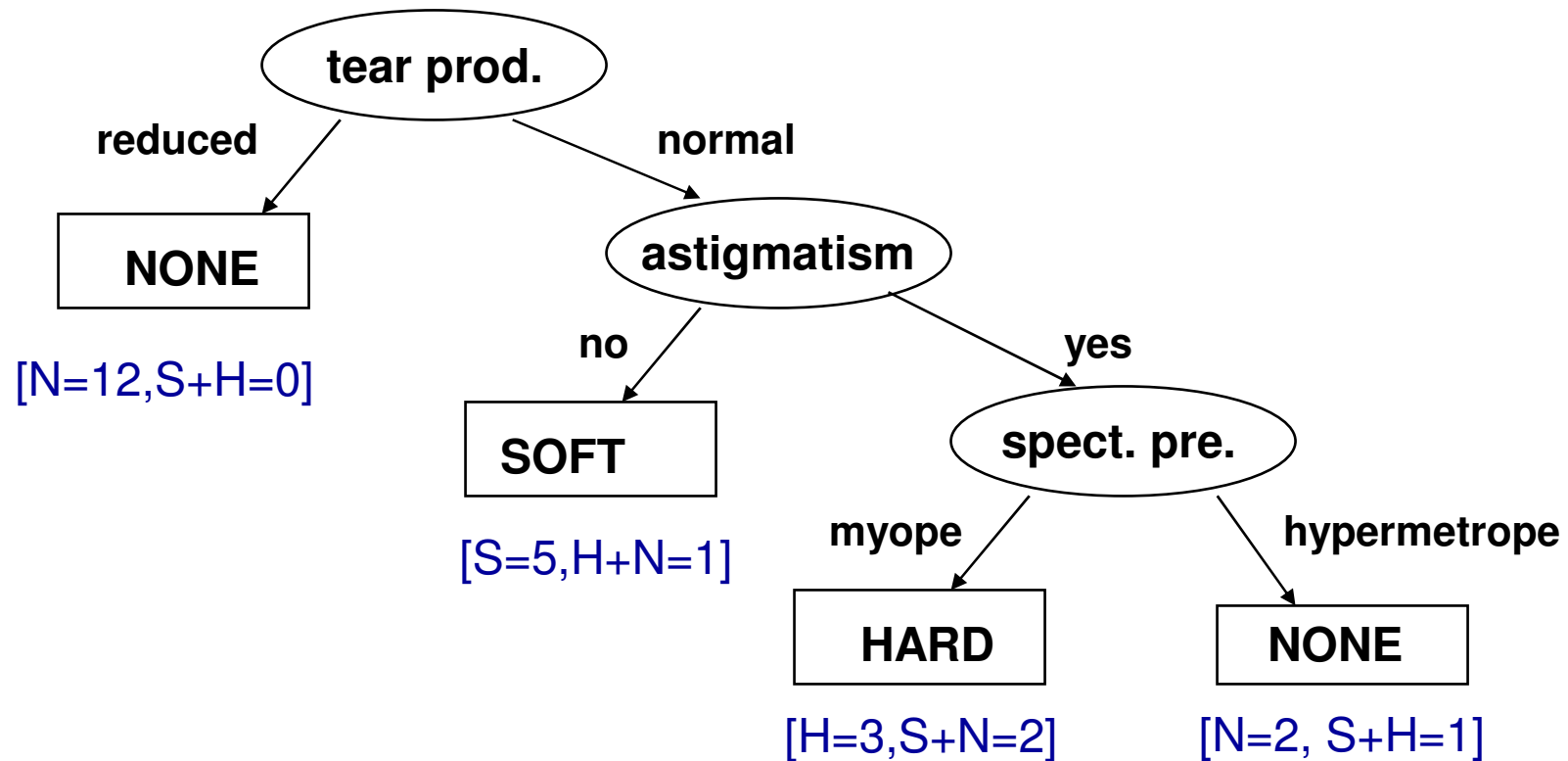

# PlayTennis: Training examples

Day	Outlook	Temperature	Humidity	Wind	PlayTennis
D1	Sunny	Hot	High	Weak	No
D2	Sunny	Hot	High	Strong	No
D3	Overcast	Hot	High	Weak	Yes
D4	Rain	Mild	High	Weak	Yes
D5	Rain	Cool	Normal	Weak	Yes
D6	Rain	Cool	Normal	Strong	No
D7	Overcast	Cool	Normal	Strong	Yes
D8	Sunny	Mild	High	Weak	No
D9	Sunny	Cool	Normal	Weak	Yes
D10	Rain	Mild	Normal	Weak	Yes
D11	Sunny	Mild	Normal	Strong	Yes
D12	Overcast	Mild	High	Weak	Yes
D13	Overcast	Hot	Normal	Weak	Yes
D14	Rain	Mild	High	Strong	No

# Decision tree representation for PlayTennis

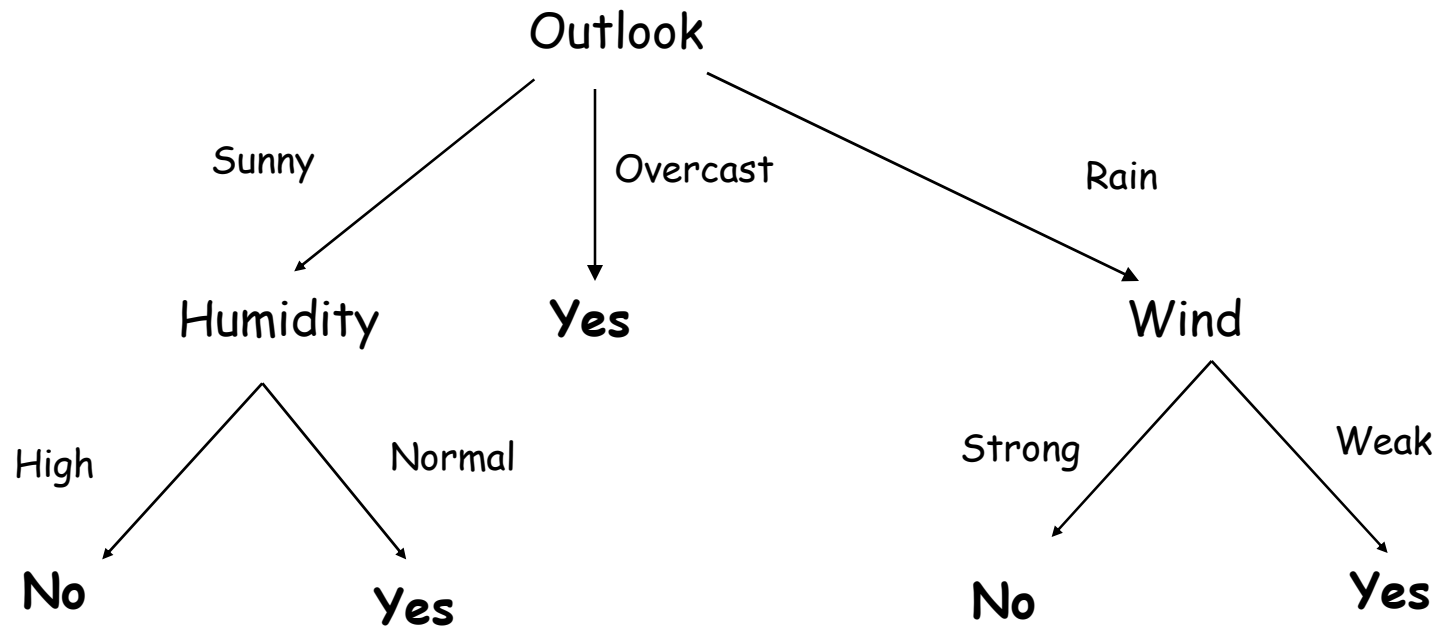

- each internal node is a test of an attribute
- each branch corresponds to an attribute value
- each path is a conjunction of attribute values
- each leaf node assigns a classification



# Decision tree representation for PlayTennis

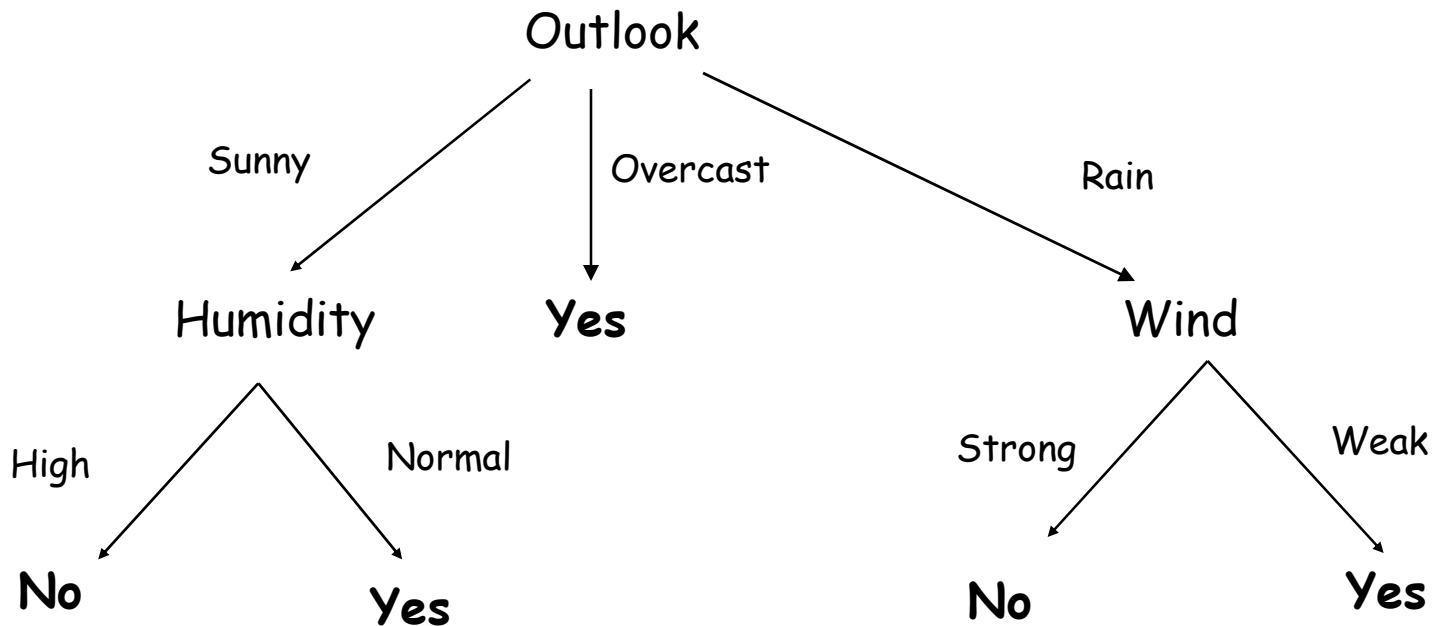

Decision trees represent a disjunction of conjunctions of constraints on the attribute values of instances

$$\begin{aligned}
 & ( \text{Outlook}=\text{Sunny} \wedge \text{Humidity}=\text{Normal} ) \\
 \vee & \quad ( \text{Outlook}=\text{Overcast} ) \\
 \vee & \quad ( \text{Outlook}=\text{Rain} \wedge \text{Wind}=\text{Weak} )
 \end{aligned}$$

# PlayTennis:

## Other representations

- Logical expression for PlayTennis=Yes:
  - $(\text{Outlook}=\text{Sunny} \wedge \text{Humidity}=\text{Normal}) \vee (\text{Outlook}=\text{Overcast}) \vee (\text{Outlook}=\text{Rain} \wedge \text{Wind}=\text{Weak})$
- Converting a tree to if-then rules
  - **IF** Outlook=Sunny  $\wedge$  Humidity=Normal **THEN** PlayTennis=Yes
  - **IF** Outlook=Overcast **THEN** PlayTennis=Yes
  - **IF** Outlook=Rain  $\wedge$  Wind=Weak **THEN** PlayTennis=Yes
  - **IF** Outlook=Sunny  $\wedge$  Humidity=High **THEN** PlayTennis=No
  - **IF** Outlook=Rain  $\wedge$  Wind=Strong **THEN** PlayTennis=No

# PlayTennis: Using a decision tree for classification

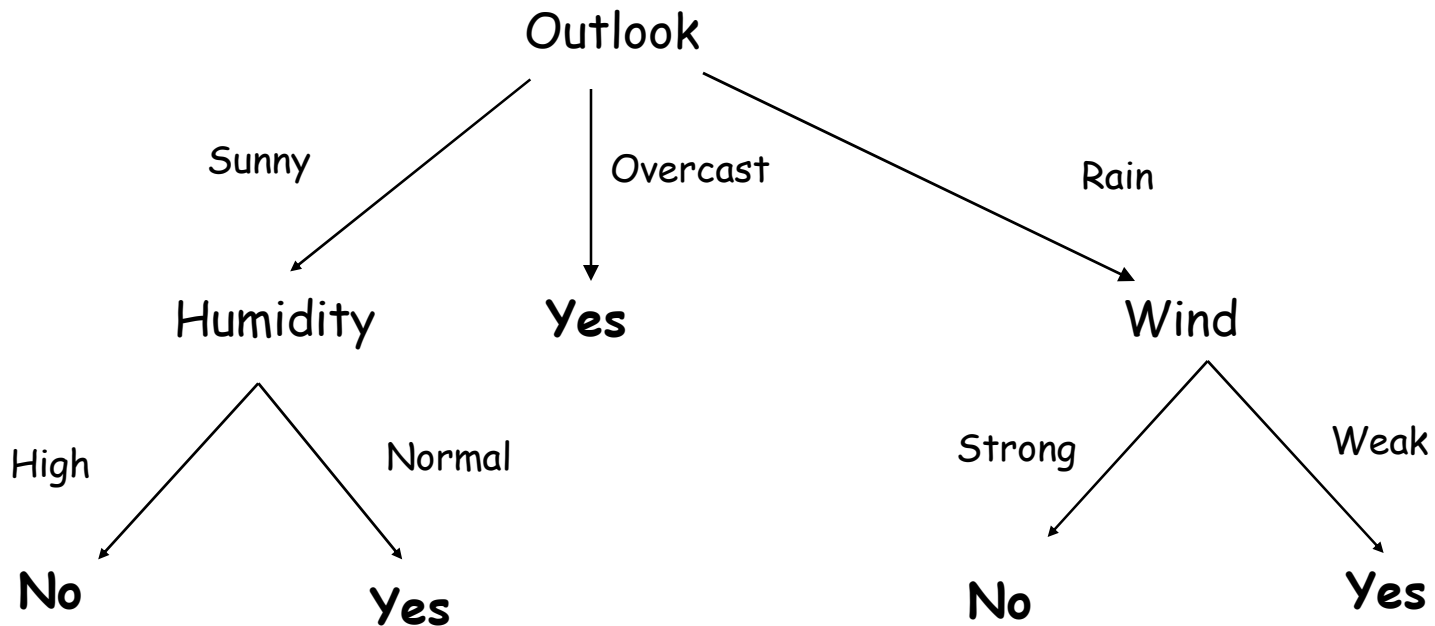

Is Saturday morning OK for playing tennis?

Outlook=Sunny, Temperature=Hot, Humidity=High, Wind=Strong

PlayTennis = No, because Outlook=Sunny  $\wedge$  Humidity=High

# Appropriate problems for decision tree learning

- Classification problems: classify an instance into one of a discrete set of possible categories (medical diagnosis, classifying loan applicants, ...)
- Characteristics:
  - instances described by attribute-value pairs  
(discrete or real-valued attributes)
  - target function has discrete output values  
(boolean or multi-valued, if real-valued then regression trees)
  - disjunctive hypothesis may be required
  - training data may be noisy  
(classification errors and/or errors in attribute values)
  - training data may contain missing attribute values

# Learning of decision trees

- ID3 (Quinlan 1979), CART (Breiman et al. 1984), C4.5, WEKA, ...
  - create the root node of the tree
  - if all examples from  $S$  belong to the same class  $C_j$ 
    - then label the root with  $C_j$
  - else
    - select the ‘most informative’ attribute **A** with values **v1, v2, ... vn**
    - divide training set **S** into **S1, ... , Sn** according to values **v1, ..., vn**
    - recursively build sub-trees **T1, ..., Tn** for **S1, ..., Sn**

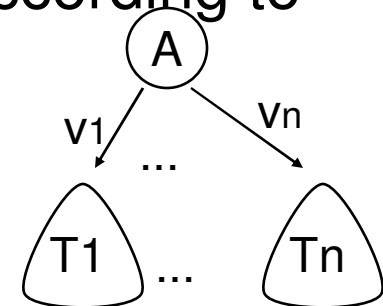

# Search heuristics in ID3

- Central choice in ID3: Which attribute to test at each node in the tree ? The attribute that is most useful for classifying examples.
- Define a statistical property, called **information gain**, measuring how well a given attribute separates the training examples w.r.t their target classification.
- First define a measure commonly used in information theory, called **entropy**, to characterize the (im)purity of an arbitrary collection of examples.

# Entropy

- **S** - training set, **C<sub>1</sub>, ..., C<sub>N</sub>** - classes
- **Entropy E(S)** – measure of the impurity of training set S

$$E(S) = - \sum_{c=1}^N p_c \cdot \log_2 p_c$$

$p_c$  - prior probability of class **C<sub>c</sub>**  
(relative frequency of **C<sub>c</sub>** in **S**)

- Entropy in binary classification problems

$$E(S) = - p_+ \log_2 p_+ - p_- \log_2 p_-$$

# Entropy

- $E(S) = - p_+ \log_2 p_+ - p_- \log_2 p_-$ .
- The entropy function relative to a Boolean classification, as the proportion  $p_+$  of positive examples varies between 0 and 1

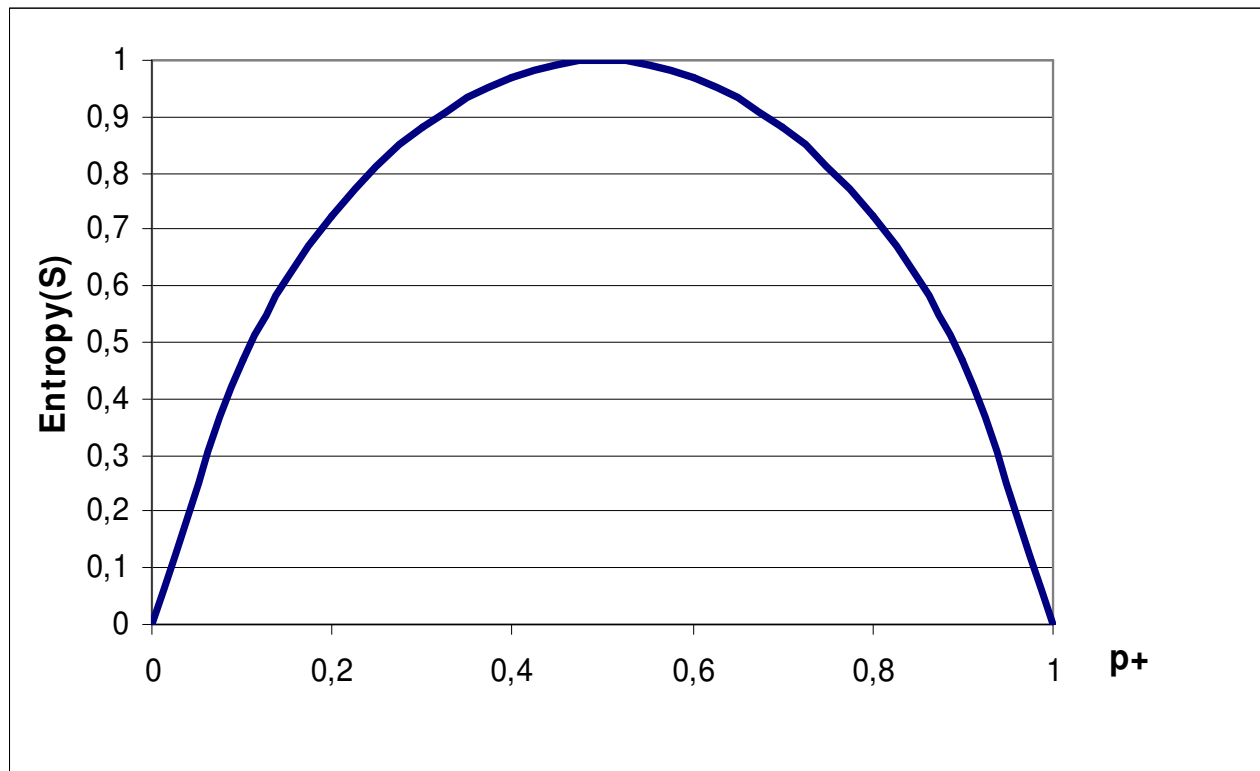



# Entropy – why ?

- **Entropy  $E(S)$**  = expected amount of information (in bits) needed to assign a class to a randomly drawn object in  $S$  (under the optimal, shortest-length code)
- Why ?
- Information theory: optimal length code assigns  $-\log_2 p$  bits to a message having probability  $p$
- So, in binary classification problems, the expected number of bits to encode + or – of a random member of  $S$  is:

$$p_+ (-\log_2 p_+) + p_- (-\log_2 p_-) = -p_+ \log_2 p_+ - p_- \log_2 p_-$$

# PlayTennis: Entropy

- Training set  $S$ : 14 examples (9 pos., 5 neg.)
- Notation:  $S = [9+, 5-]$
- $E(S) = -p_+ \log_2 p_+ - p_- \log_2 p_-$
- Computing entropy, if probability is estimated by relative frequency

$$E(S) = -\left(\frac{|S_+|}{|S|} \cdot \log \frac{|S_+|}{|S|}\right) - \left(\frac{|S_-|}{|S|} \cdot \log \frac{|S_-|}{|S|}\right)$$

- $E([9+,5-]) = - (9/14) \log_2(9/14) - (5/14) \log_2(5/14)$   
 $= 0.940$

# PlayTennis: Entropy

- $E(S) = - p_+ \log_2 p_+ - p_- \log_2 p_-$ .
- $E(9+,5-) = -(9/14) \log_2(9/14) - (5/14) \log_2(5/14) = 0.940$

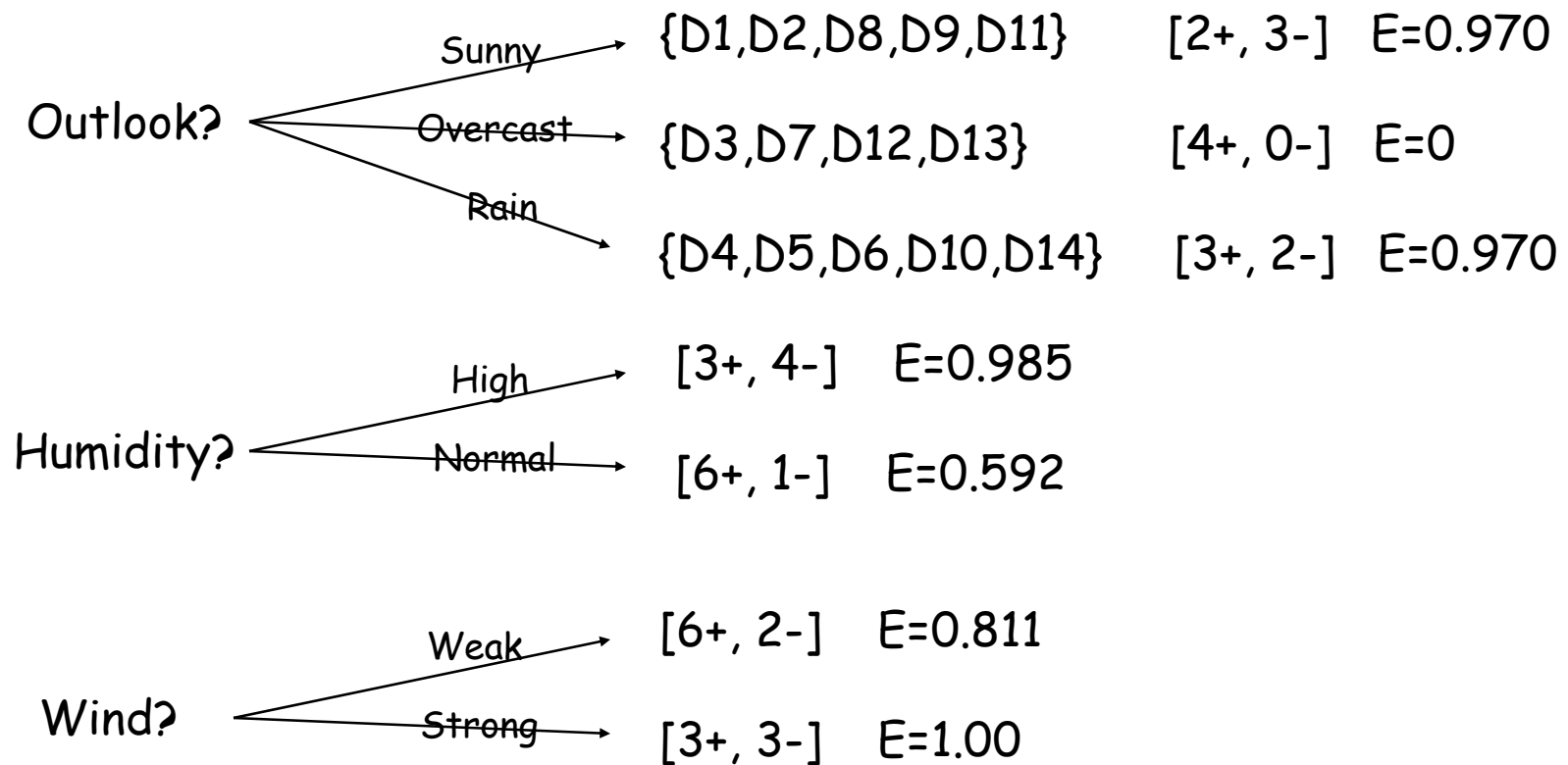

# Information gain search heuristic

- **Information gain** measure is aimed to minimize the number of tests needed for the classification of a new object
- **Gain(S,A)** – expected reduction in entropy of S due to sorting on A

$$Gain(S, A) = E(S) - \sum_{v \in Values(A)} \frac{|S_v|}{|S|} \cdot E(S_v)$$

- **Most informative attribute: max Gain(S,A)**

# Information gain search heuristic

- Which attribute is more informative, A1 or A2 ?

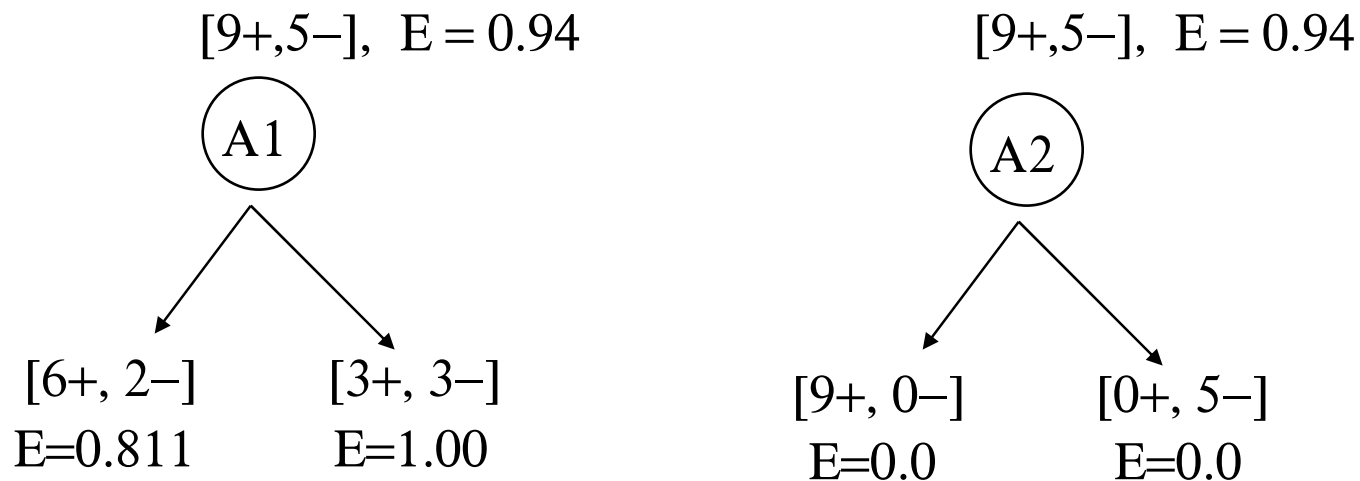

- $\text{Gain}(S, A1) = 0.94 - (8/14 \times 0.811 + 6/14 \times 1.00) = 0.048$
- $\text{Gain}(S, A2) = 0.94 - 0 = 0.94$                       A2 has max Gain

# PlayTennis: Information gain

$$Gain(S, A) = E(S) - \sum_{v \in Values(A)} \frac{|S_v|}{|S|} \cdot E(S_v)$$

- $Values(Wind) = \{Weak, Strong\}$

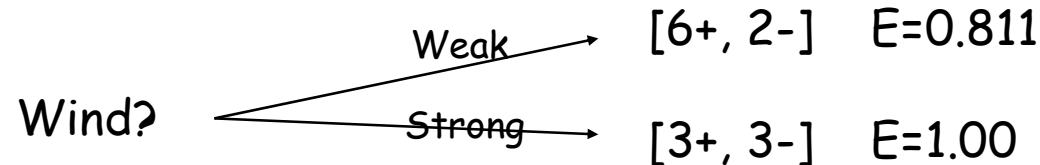

- $S = [9+, 5-], E(S) = 0.940$
- $S_{weak} = [6+, 2-], E(S_{weak}) = 0.811$
- $S_{strong} = [3+, 3-], E(S_{strong}) = 1.0$
- **Gain(S, Wind) =  $E(S) - (8/14)E(S_{weak}) - (6/14)E(S_{strong}) = 0.940 - (8/14) \times 0.811 - (6/14) \times 1.0 = 0.048$**

# PlayTennis: Information gain

- **Which attribute is the best?**
  - $\text{Gain}(S, \text{Outlook}) = 0.246$       *MAX !*
  - $\text{Gain}(S, \text{Humidity}) = 0.151$
  - $\text{Gain}(S, \text{Wind}) = 0.048$
  - $\text{Gain}(S, \text{Temperature}) = 0.029$

# PlayTennis: Information gain

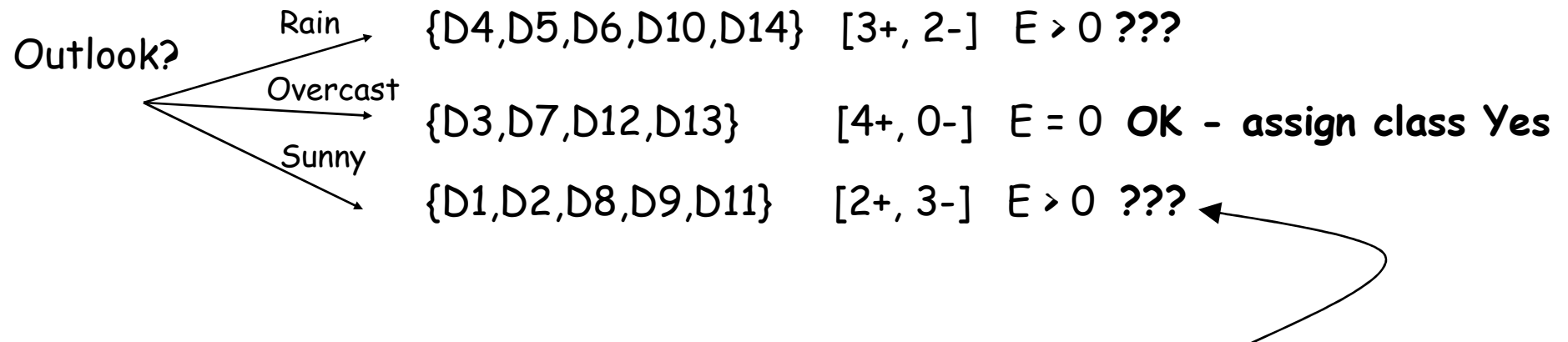

- Which attribute should be tested here?
  - $\text{Gain}(S_{\text{sunny}}, \text{Humidity}) = 0.97 - (3/5)0 - (2/5)0 = 0.970$  **MAX !**
  - $\text{Gain}(S_{\text{sunny}}, \text{Temperature}) = 0.97 - (2/5)0 - (2/5)1 - (1/5)0 = 0.570$
  - $\text{Gain}(S_{\text{sunny}}, \text{Wind}) = 0.97 - (2/5)1 - (3/5)0.918 = 0.019$



# Probability estimates

- **Relative frequency :**
  - problems with small samples

$$p(\text{Class} | \text{Cond}) = \frac{n(\text{Class}.\text{Cond})}{n(\text{Cond})}$$

$$[6+, 1-] (7) = 6/7$$

$$[2+, 0-] (2) = 2/2 = 1$$

- **Laplace estimate :**
  - assumes uniform prior distribution of k classes

$$= \frac{n(\text{Class}.\text{Cond}) + 1}{n(\text{Cond}) + k} \quad k = 2$$

$$[6+, 1-] (7) = 6+1 / 7+2 = 7/9$$

$$[2+, 0-] (2) = 2+1 / 2+2 = 3/4$$

# Heuristic search in ID3

- **Search bias:** Search the space of decision trees from simplest to increasingly complex (greedy search, no backtracking, prefer small trees)
- **Search heuristics:** At a node, select the attribute that is most useful for classifying examples, split the node accordingly
- **Stopping criteria:** A node becomes a leaf
  - if all examples belong to same class  $C_j$ , label the leaf with  $C_j$
  - if all attributes were used, label the leaf with the most common value  $C_k$  of examples in the node
- **Extension to ID3:** handling noise - tree pruning

# Pruning of decision trees

- Avoid overfitting the data by tree pruning
- Pruned trees are
  - less accurate on training data
  - more accurate when classifying unseen data

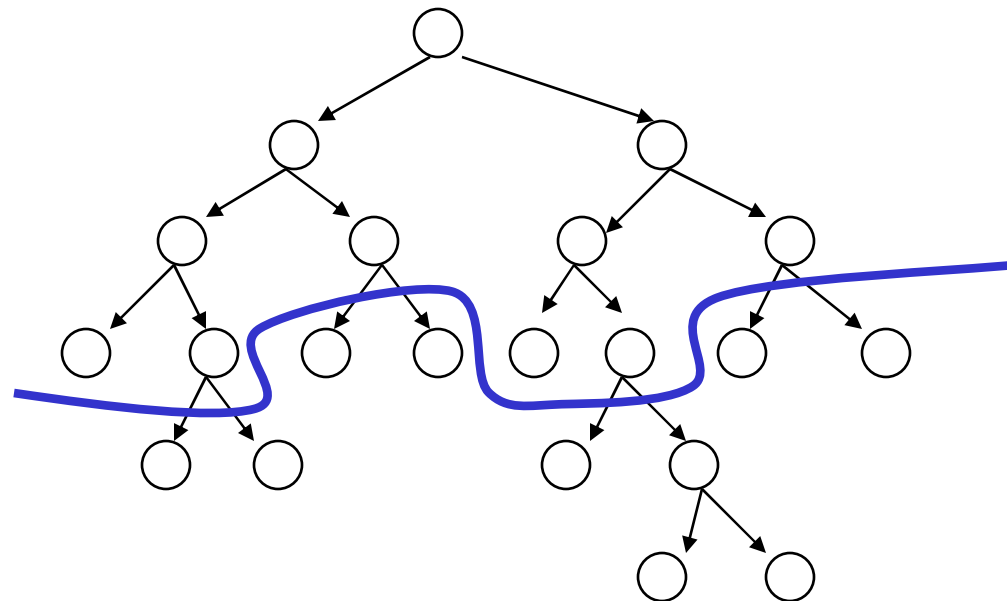

# Handling noise – Tree pruning

Sources of imperfection

1. Random errors (noise) in training examples
  - erroneous attribute values
  - erroneous classification
2. Too sparse training examples (incompleteness)
3. Inappropriate/insufficient set of attributes (inexactness)
4. Missing attribute values in training examples

# Handling noise – Tree pruning

- Handling imperfect data
  - handling imperfections of type 1-3
    - pre-pruning (stopping criteria)
    - post-pruning / rule truncation
  - handling missing values
- Pruning avoids perfectly fitting noisy data: relaxing the completeness (fitting all +) and consistency (fitting all -) criteria in ID3

# Prediction of breast cancer recurrence: Tree pruning

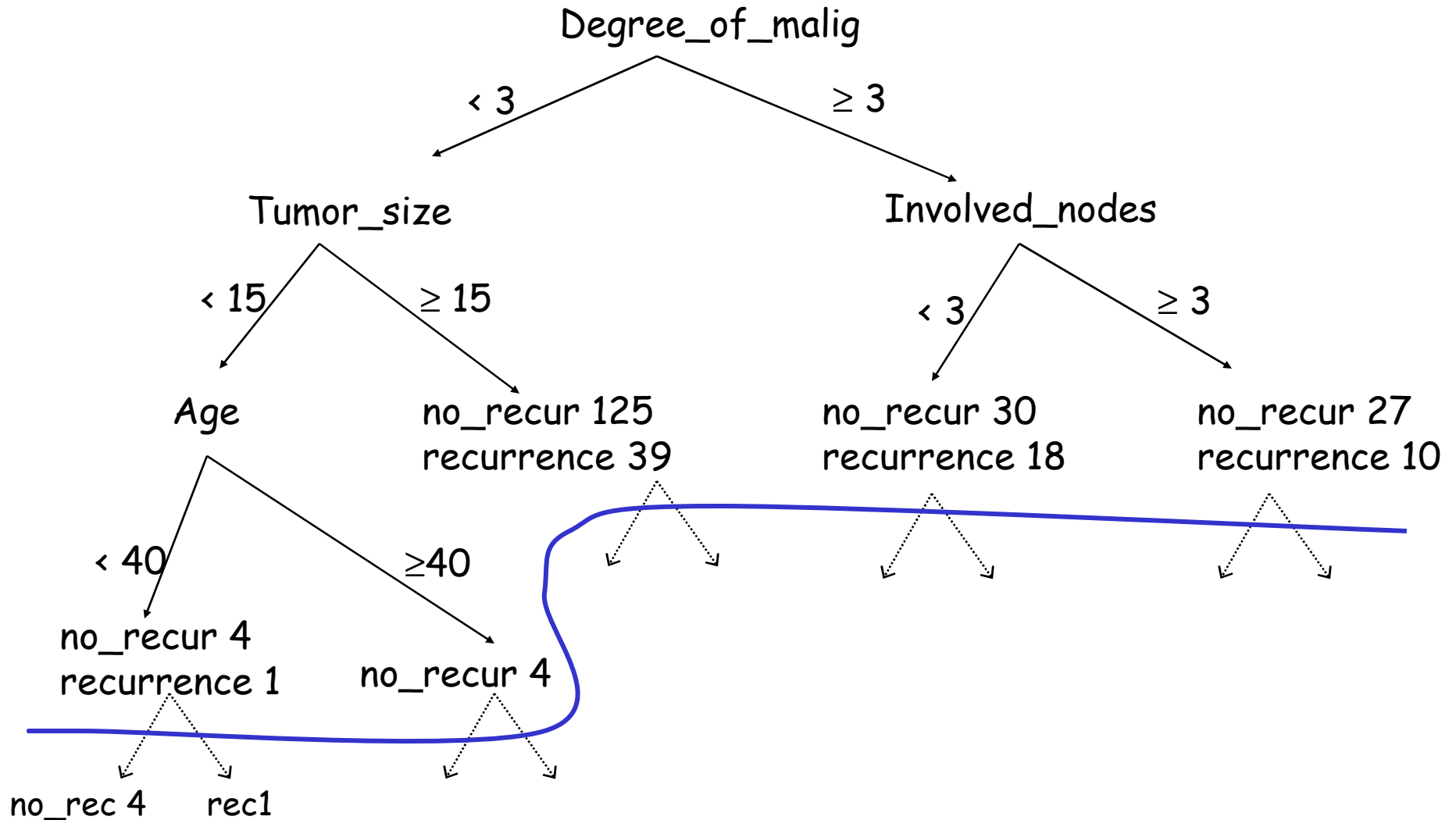

# Accuracy and error

- Accuracy: percentage of correct classifications
  - on the training set
  - on unseen instances
- How accurate is a decision tree when classifying unseen instances
  - An estimate of accuracy on unseen instances can be computed, e.g., by averaging over 4 runs:
    - split the example set into training set (e.g. 70%) and test set (e.g. 30%)
    - induce a decision tree from training set, compute its accuracy on test set
- Error = 1 - Accuracy
- High error may indicate data overfitting

# Overfitting and accuracy

- Typical relation between tree size and accuracy

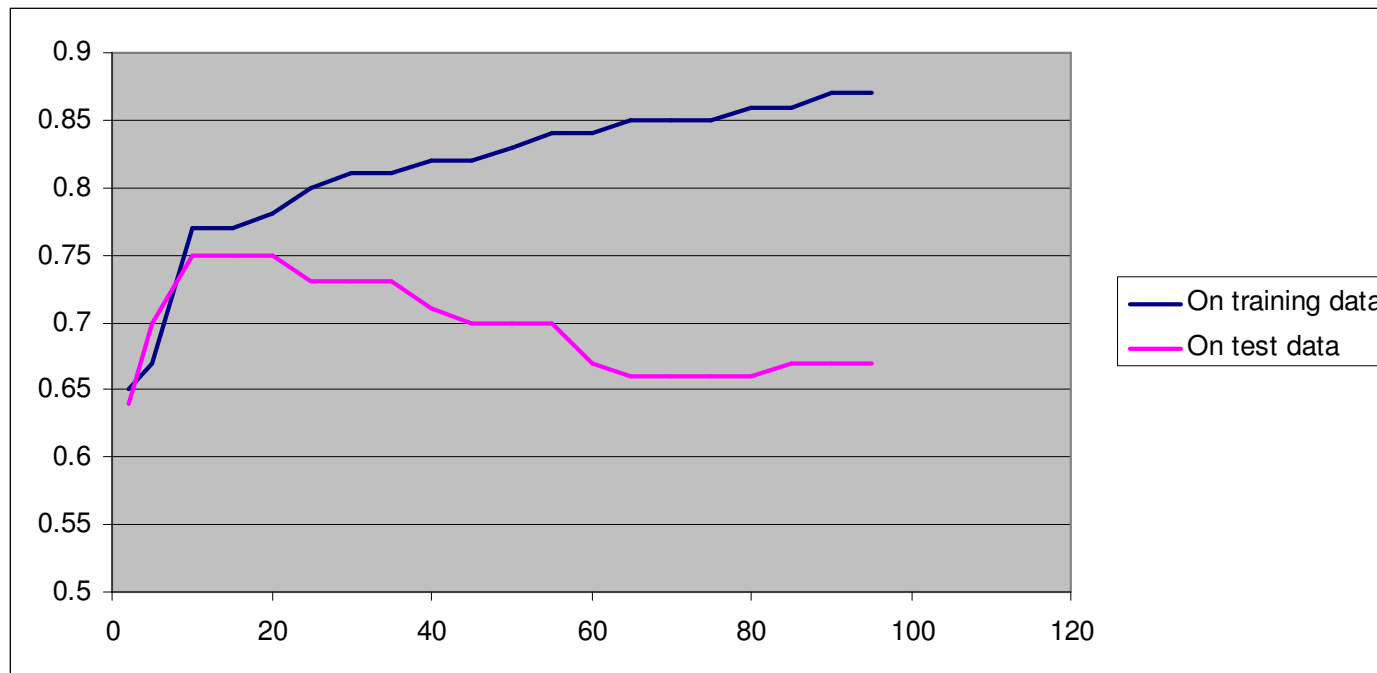

- Question: how to prune optimally?



# Avoiding overfitting

- How can we avoid overfitting?
  - Pre-pruning (forward pruning): stop growing the tree e.g., when data split not statistically significant or too few examples are in a split
  - Post-pruning: grow full tree, then post-prune

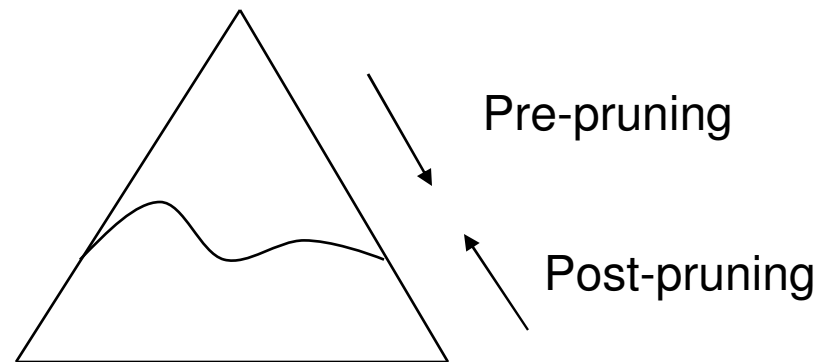

- forward pruning considered inferior (myopic)
- post pruning makes use of sub trees

# How to select the “best” tree

- Measure performance over training data (e.g., pessimistic post-pruning, Quinlan 1993)
- Measure performance over separate validation data set (e.g., reduced error pruning, Quinlan 1987)
  - until further pruning is harmful DO:
    - for each node evaluate the impact of replacing a subtree by a leaf, assigning the majority class of examples in the leaf, if the pruned tree performs no worse than the original over the validation set
    - greedily select the node whose removal most improves tree accuracy over the validation set
- MDL: minimize  
 $\text{size}(\text{tree}) + \text{size}(\text{misclassifications}(\text{tree}))$

# Selected decision/regression tree learners

- Decision tree learners
  - ID3 (Quinlan 1979)
  - CART (Breiman et al. 1984)
  - Assistant (Cestnik et al. 1987)
  - C4.5 (Quinlan 1993), C5 (See5, Quinlan)
  - J48 (available in WEKA)
- Regression tree learners, model tree learners
  - M5, M5P (implemented in WEKA)

# Features of C4.5

- Implemented as part of the WEKA data mining workbench
- Handling noisy data: post-pruning
- Handling incompletely specified training instances: 'unknown' values (?)
  - in learning assign conditional probability of value  $v$ :  
$$p(v|C) = p(vC) / p(C)$$
  - in classification: follow all branches, weighted by prior prob. of missing attribute values

# Other features of C4.5

- Binarization of attribute values
  - for continuous values select a boundary value maximally increasing the informativity of the attribute: sort the values and try every possible split (done automatically)
  - for discrete values try grouping the values until two groups remain \*
- ‘Majority’ classification in NULL leaf (with no corresponding training example)
  - if an example ‘falls’ into a NULL leaf during classification, the class assigned to this example is the majority class of the parent of the NULL leaf

\* the basic C4.5 doesn't support binarisation of discrete attributes, it supports grouping

## Part II. Predictive DM techniques

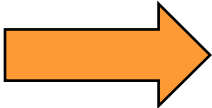
- Naïve Bayesian classifier
- Decision tree learning
-  • Classification rule learning
- Classifier evaluation

# Rule Learning in a Nutshell

Person	Age	Spect. presc.	Astigm.	Tear prod.	Lenses
O1	young	myope	no	reduced	NONE
O2	young	myope	no	normal	SOFT
O3	young	myope	yes	reduced	NONE
O4	young	myope	yes	normal	HARD
O5	young	hypermetrope	no	reduced	NONE
O6-O13	...	...	...	...	...
O14	pre-presbyc	hypermetrope	no	normal	SOFT
O15	pre-presbyc	hypermetrope	yes	reduced	NONE
O16	pre-presbyc	hypermetrope	yes	normal	NONE
O17	presbyopic	myope	no	reduced	NONE
O18	presbyopic	myope	no	normal	NONE
O19-O23	...	...	...	...	...
O24	presbyopic	hypermetrope	yes	normal	NONE

data

knowledge discovery  
from data

Rule learning

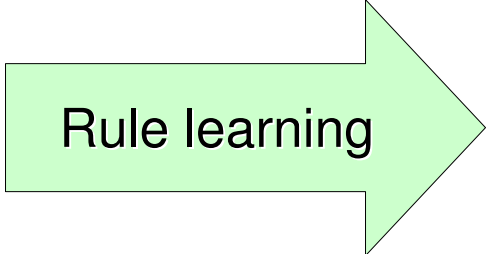

Model: a set of rules

Patterns: individual rules

**Given:** transaction data table, relational database (a set of objects, described by attribute values)

**Find:** a classification model in the form of a set of rules;  
or a set of interesting patterns in the form of individual rules

# Rule set representation

- Rule base is a disjunctive set of conjunctive rules

- Standard form of rules:

IF Condition THEN Class

Class IF Conditions

Class  $\leftarrow$  Conditions

**IF Outlook=Sunny  $\wedge$  Humidity=Normal THEN**

PlayTennis=Yes

**IF Outlook=Overcast THEN PlayTennis=Yes**

**IF Outlook=Rain  $\wedge$  Wind=Weak THEN PlayTennis=Yes**

- Form of CN2 rules:

IF Conditions THEN MajClass [ClassDistr]

- Rule base: {R1, R2, R3, ..., DefaultRule}



# Data mining example

## Input: Contact lens data

Person	Age	Spect. presc.	Astigm.	Tear prod.	Lenses
O1	young	myope	no	reduced	NONE
O2	young	myope	no	normal	SOFT
O3	young	myope	yes	reduced	NONE
O4	young	myope	yes	normal	HARD
O5	young	hypermetrope	no	reduced	NONE
O6-O13	...	...	...	...	...
O14	pre-presbyc	hypermetrope	no	normal	SOFT
O15	pre-presbyc	hypermetrope	yes	reduced	NONE
O16	pre-presbyc	hypermetrope	yes	normal	NONE
O17	presbyopic	myope	no	reduced	NONE
O18	presbyopic	myope	no	normal	NONE
O19-O23	...	...	...	...	...
O24	presbyopic	hypermetrope	yes	normal	NONE

# Contact lens data: Classification rules

**Type of task:** prediction and classification

**Hypothesis language:** rules  $X \rightarrow C$ , if  $X$  then  $C$   
 $X$  conjunction of attribute values,  $C$  class

tear production=reduced  $\rightarrow$  **lenses=NONE**

tear production=normal & astigmatism=yes &  
spect. pre.=hypermetrope  $\rightarrow$  **lenses=NONE**

tear production=normal & astigmatism=no  $\rightarrow$   
**lenses=SOFT**

tear production=normal & astigmatism=yes &  
spect. pre.=myope  $\rightarrow$  **lenses=HARD**

DEFAULT **lenses=NONE**

# Rule learning

- Two rule learning approaches:
  - Learn decision tree, convert to rules
  - Learn set/list of rules
    - Learning an unordered set of rules
    - Learning an ordered list of rules
- Heuristics, overfitting, pruning

# Contact lenses: convert decision tree to an unordered rule set

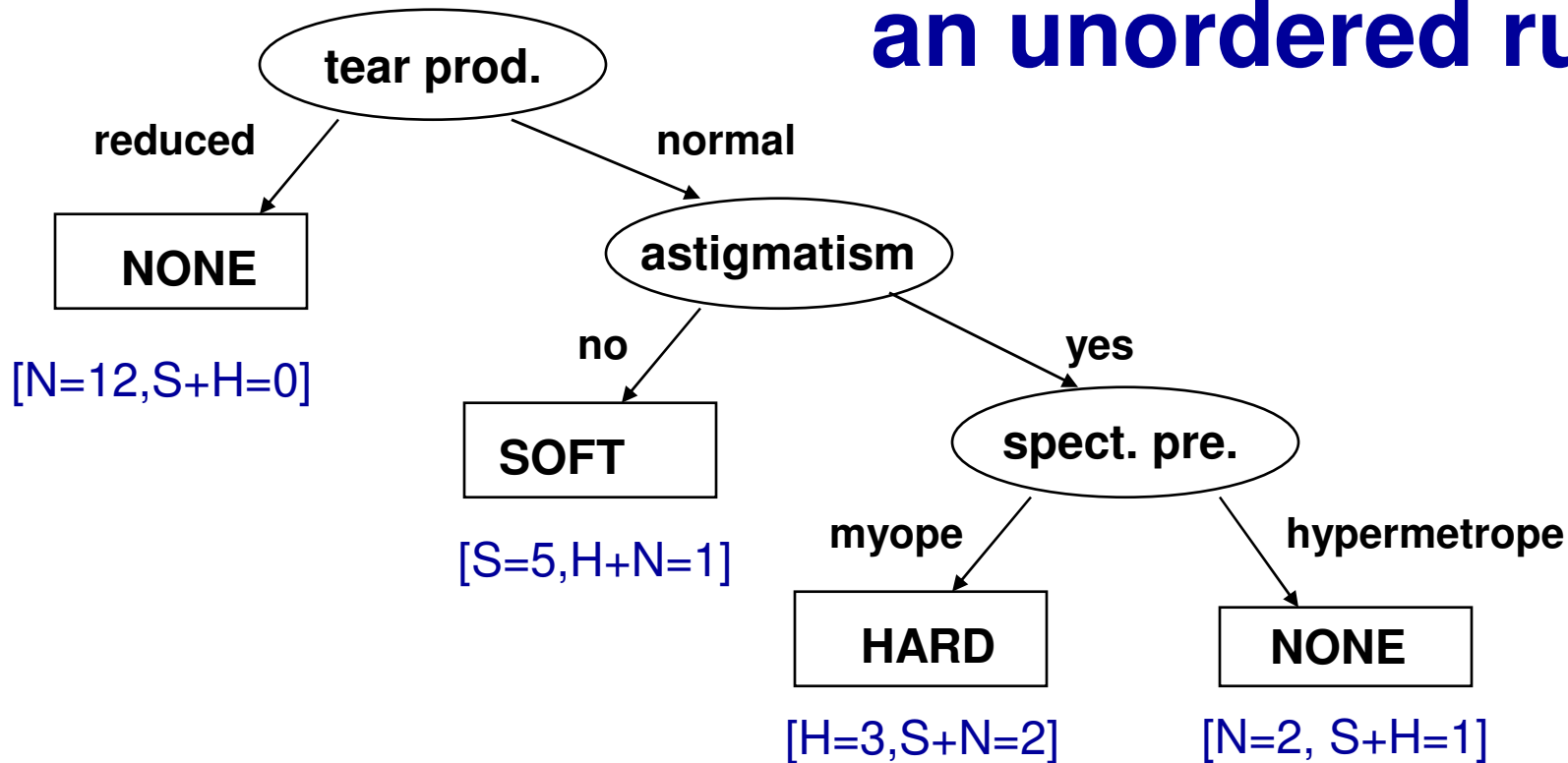

tear production=reduced => lenses=NONE [S=0,H=0,N=12]

tear production=normal & astigmatism=yes & spect. pre.=hypermetrope => lenses=NONE [S=0,H=1,N=2]

tear production=normal & astigmatism=no => lenses=SOFT [S=5,H=0,N=1]

tear production=normal & astigmatism=yes & spect. pre.=myope => lenses=HARD [S=0,H=3,N=2]

DEFAULT lenses=NONE

Order independent rule set (may overlap)

# Contact lenses: convert decision tree to decision list

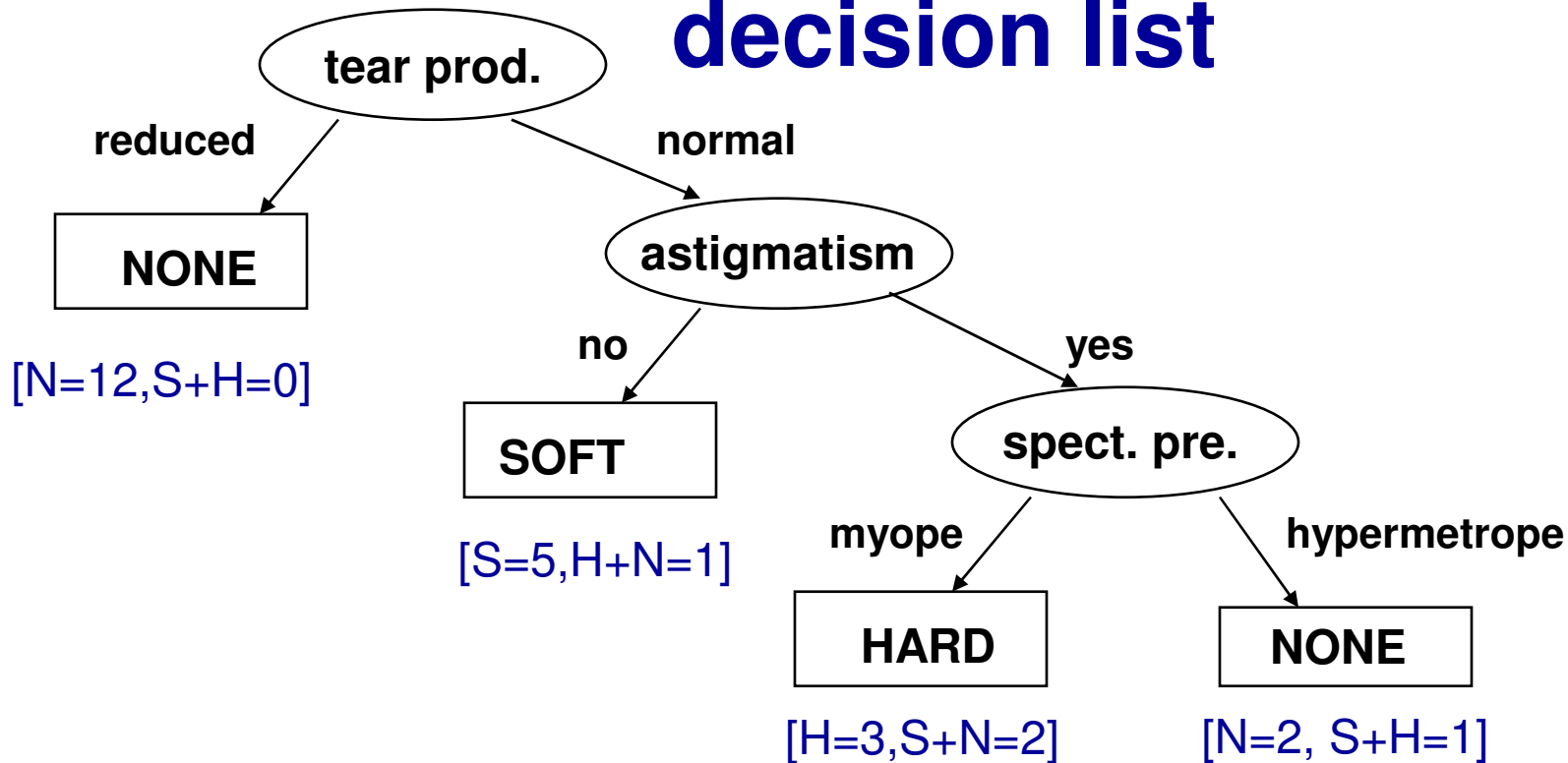

```

IF tear production=reduced THEN lenses=NONE
ELSE /*tear production=normal*/
  IF astigmatism=no THEN lenses=SOFT
  ELSE /*astigmatism=yes*/
    IF spect. pre.=myope THEN lenses=HARD
    ELSE /* spect.pre.=hypermetrope*/
      lenses=NONE
  
```

Ordered (order dependent) rule list

# Converting decision tree to rules, and rule post-pruning (Quinlan 1993)

- Very frequently used method, e.g., in C4.5 and J48
- Procedure:
  - grow a full tree (allowing overfitting)
  - convert the tree to an equivalent set of rules
  - prune each rule independently of others
  - sort final rules into a desired sequence for use

## Concept learning: Task reformulation for rule learning: (pos. vs. neg. examples of Target class)

Person	Age	Spect. presc.	Astigm.	Tear prod.	Lenses
O1	young	myope	no	reduced	NO
O2	young	myope	no	normal	YES
O3	young	myope	yes	reduced	NO
O4	young	myope	yes	normal	YES
O5	young	hypermetrope	no	reduced	NO
O6-O13	...	...	...	...	...
O14	pre-presbyc	hypermetrope	no	normal	YES
O15	pre-presbyc	hypermetrope	yes	reduced	NO
O16	pre-presbyc	hypermetrope	yes	normal	NO
O17	presbyopic	myope	no	reduced	NO
O18	presbyopic	myope	no	normal	NO
O19-O23	...	...	...	...	...
O24	presbyopic	hypermetrope	yes	normal	NO

# Original covering algorithm (AQ, Michalski 1969,86)

**Given** examples of  $N$  classes  $C_1, \dots, C_N$   
**for each class  $C_i$  do**

- $E_i := P_i \cup N_i$  ( $P_i$  pos.,  $N_i$  neg.)
- $\text{RuleBase}(C_i) := \text{empty}$
- **repeat {learn-set-of-rules}**
  - **learn-one-rule**  $R$  covering some positive examples and no negatives
  - add  $R$  to  $\text{RuleBase}(C_i)$
  - delete from  $P_i$  all pos. ex. covered by  $R$
- **until**  $P_i = \text{empty}$

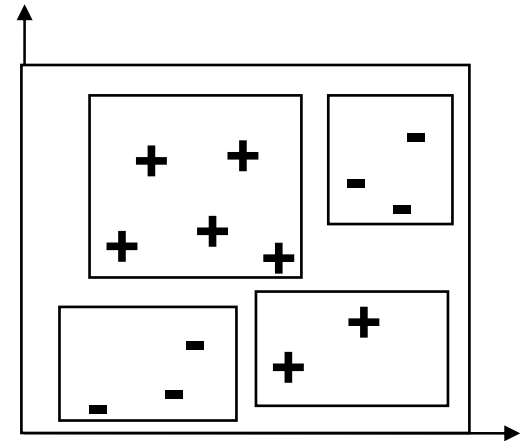



# Covering algorithm

Positive examples

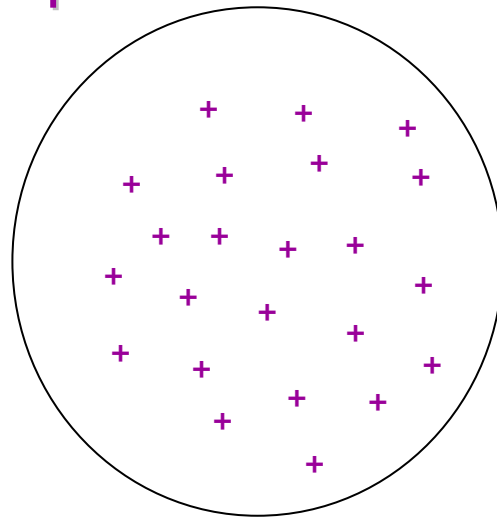

Negative examples

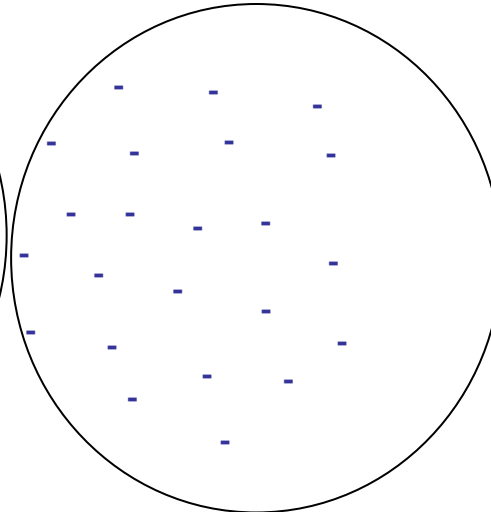

# Covering algorithm

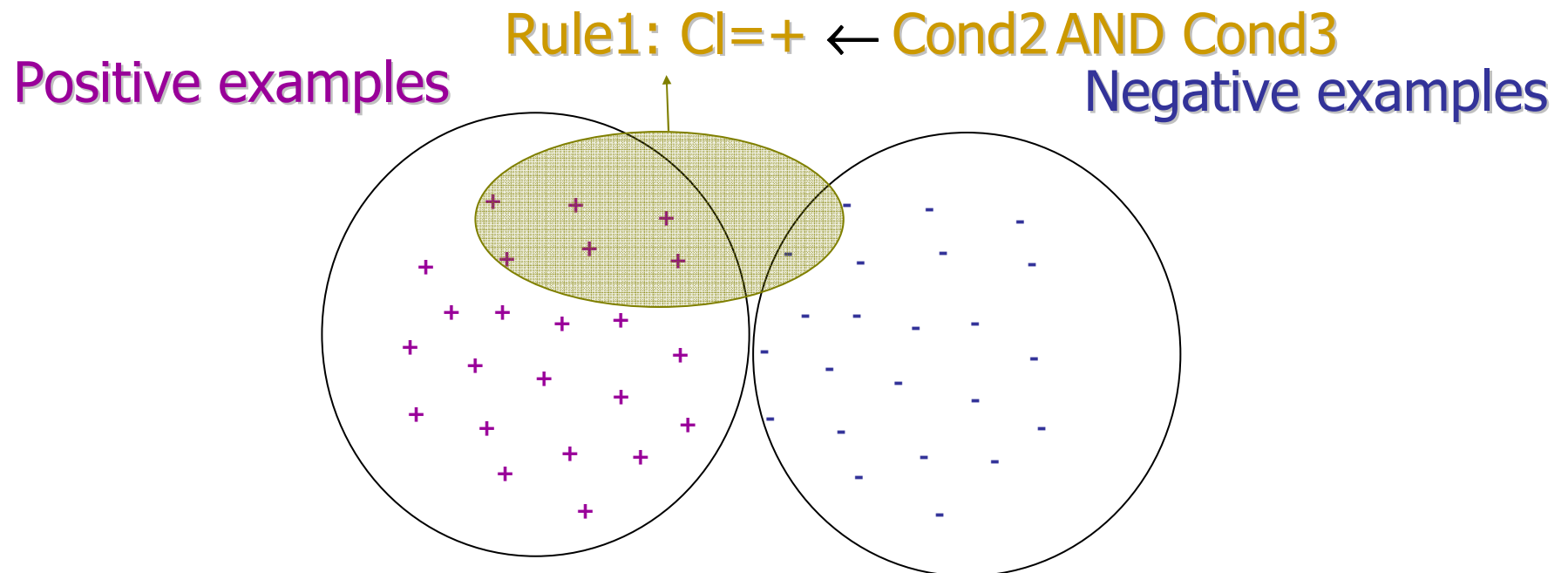

# Covering algorithm

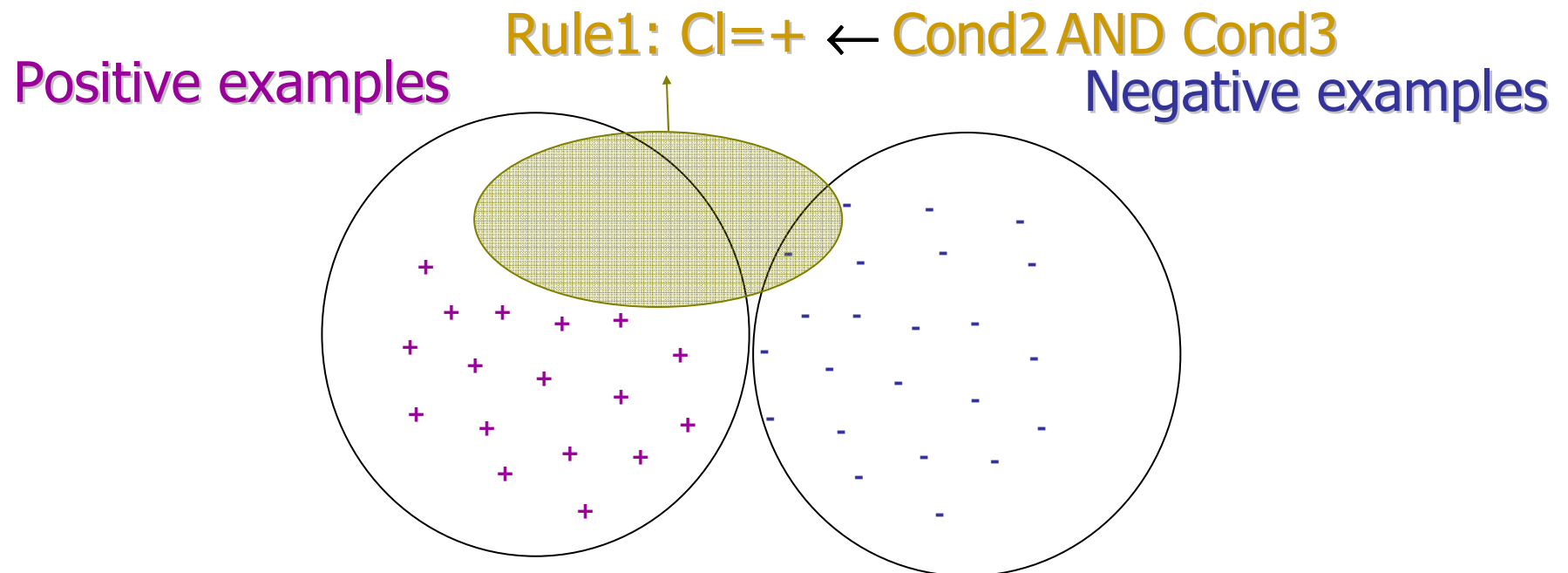

# Covering algorithm

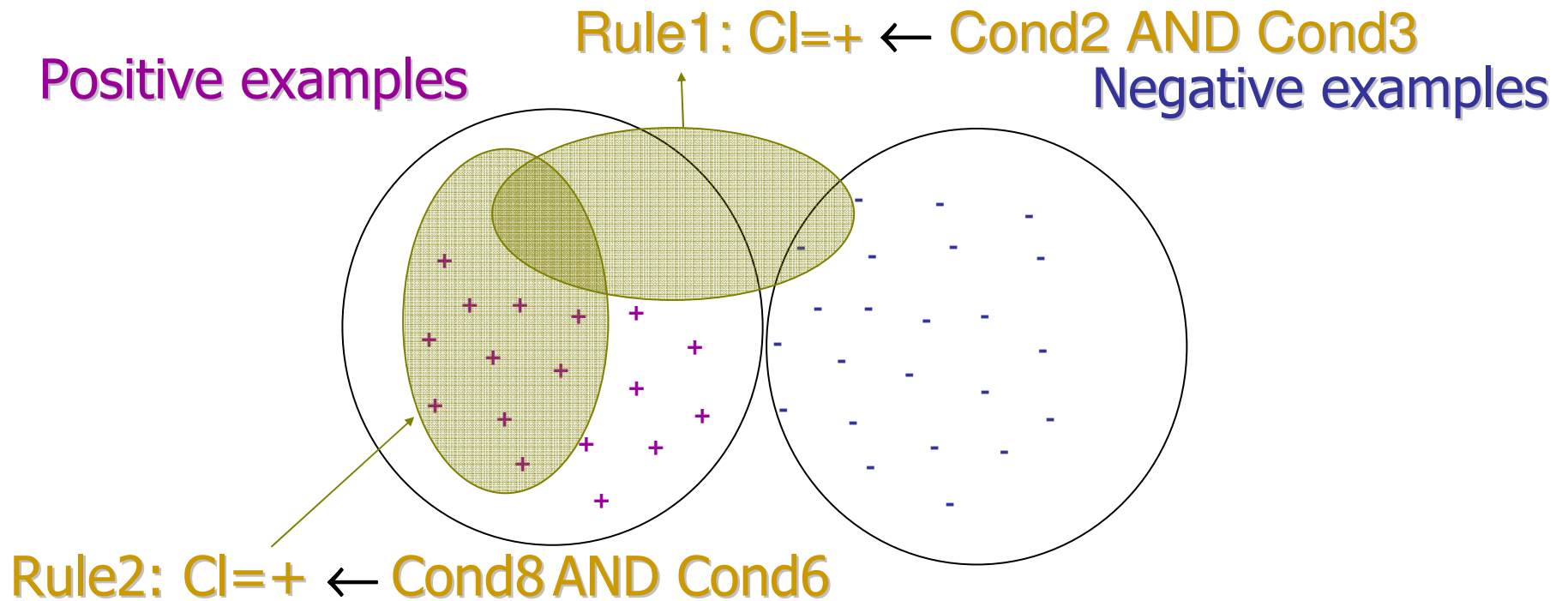

# Covering algorithm

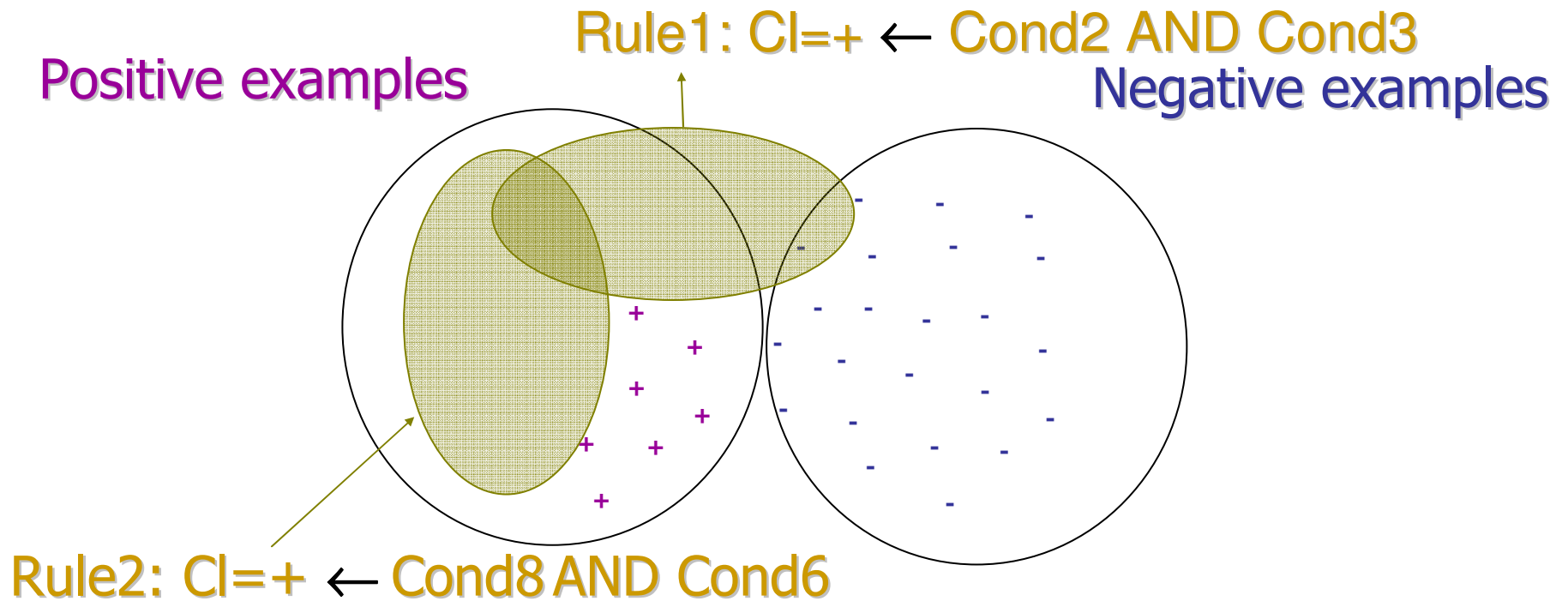

# PlayTennis: Training examples

Day	Outlook	Temperature	Humidity	Wind	PlayTennis
D1	Sunny	Hot	High	Weak	No
D2	Sunny	Hot	High	Strong	No
D3	Overcast	Hot	High	Weak	Yes
D4	Rain	Mild	High	Weak	Yes
D5	Rain	Cool	Normal	Weak	Yes
D6	Rain	Cool	Normal	Strong	No
D7	Overcast	Cool	Normal	Strong	Yes
D8	Sunny	Mild	High	Weak	No
D9	Sunny	Cool	Normal	Weak	Yes
D10	Rain	Mild	Normal	Weak	Yes
D11	Sunny	Mild	Normal	Strong	Yes
D12	Overcast	Mild	High	Weak	Yes
D13	Overcast	Hot	Normal	Weak	Yes
D14	Rain	Mild	High	Strong	No

# Heuristics for learn-one-rule: PlayTennis example

PlayTennis = yes [9+,5-] (14)

PlayTennis = yes      ← Wind=weak [6+,2-] (8)  
                              ← Wind=strong [3+,3-] (6)  
                              ← Humidity=normal [6+,1-] (7)  
                              ← ...

PlayTennis = yes      ← Humidity=normal  
    Outlook=sunny [2+,0-] (2)  
                              ← ...

Estimating **rule accuracy (rule precision)** with the **probability** that a covered example is positive

$$A(\text{Class} \leftarrow \text{Cond}) = p(\text{Class} | \text{Cond})$$

Estimating the **probability** with the **relative frequency** of covered pos. ex. / all covered ex.

$$[6+,1-] (7) = 6/7,$$

$$[2+,0-] (2) = 2/2 = 1$$

# Probability estimates

- **Relative frequency :**
  - problems with small samples

$$p(\text{Class} | \text{Cond}) = \frac{n(\text{Class}.\text{Cond})}{n(\text{Cond})}$$

$$[6+, 1-] (7) = 6/7$$

$$[2+, 0-] (2) = 2/2 = 1$$

- **Laplace estimate :**
  - assumes uniform prior distribution of k classes

$$= \frac{n(\text{Class}.\text{Cond}) + 1}{n(\text{Cond}) + k} \quad k = 2$$

$$[6+, 1-] (7) = 6+1 / 7+2 = 7/9$$

$$[2+, 0-] (2) = 2+1 / 2+2 = 3/4$$



# Learn-one-rule: search heuristics

- Assume a two-class problem
- Two classes (+,-), learn rules for + class (Cl).
- Search for specializations R' of a rule  $R = Cl \leftarrow Cond$  from the RuleBase.
- Specialization R' of rule  $R = Cl \leftarrow Cond$   
has the form  $R' = Cl \leftarrow Cond \ \& \ Cond'$
- Heuristic search for rules: find the 'best' Cond' to be added to the current rule R, such that rule accuracy is improved, e.g., such that  $Acc(R') > Acc(R)$ 
  - where the expected **classification accuracy** can be estimated as  $A(R) = p(Cl|Cond)$

# Learn-one-rule: Greedy vs. beam search

- learn-one-rule by greedy general-to-specific search, at each step selecting the `best' descendant, no backtracking
  - e.g., the best descendant of the initial rule  
PlayTennis = yes ←
  - is rule PlayTennis = yes ← Humidity=normal
- beam search: maintain a list of k best candidates at each step; descendants (specializations) of each of these k candidates are generated, and the resulting set is again reduced to k best candidates

# Learn-one-rule as search: PlayTennis example

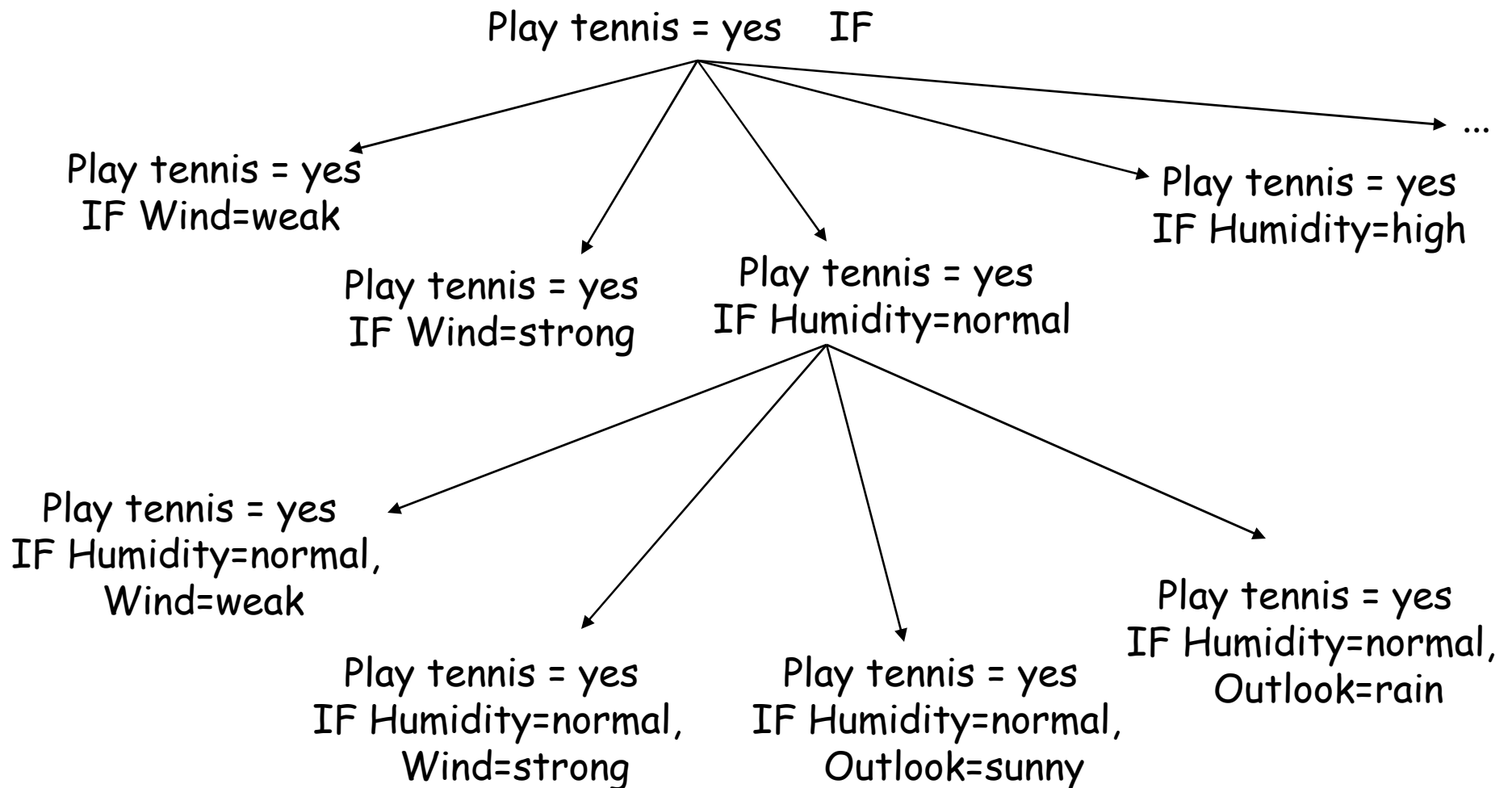

# Learn-one-rule as heuristic search: PlayTennis example

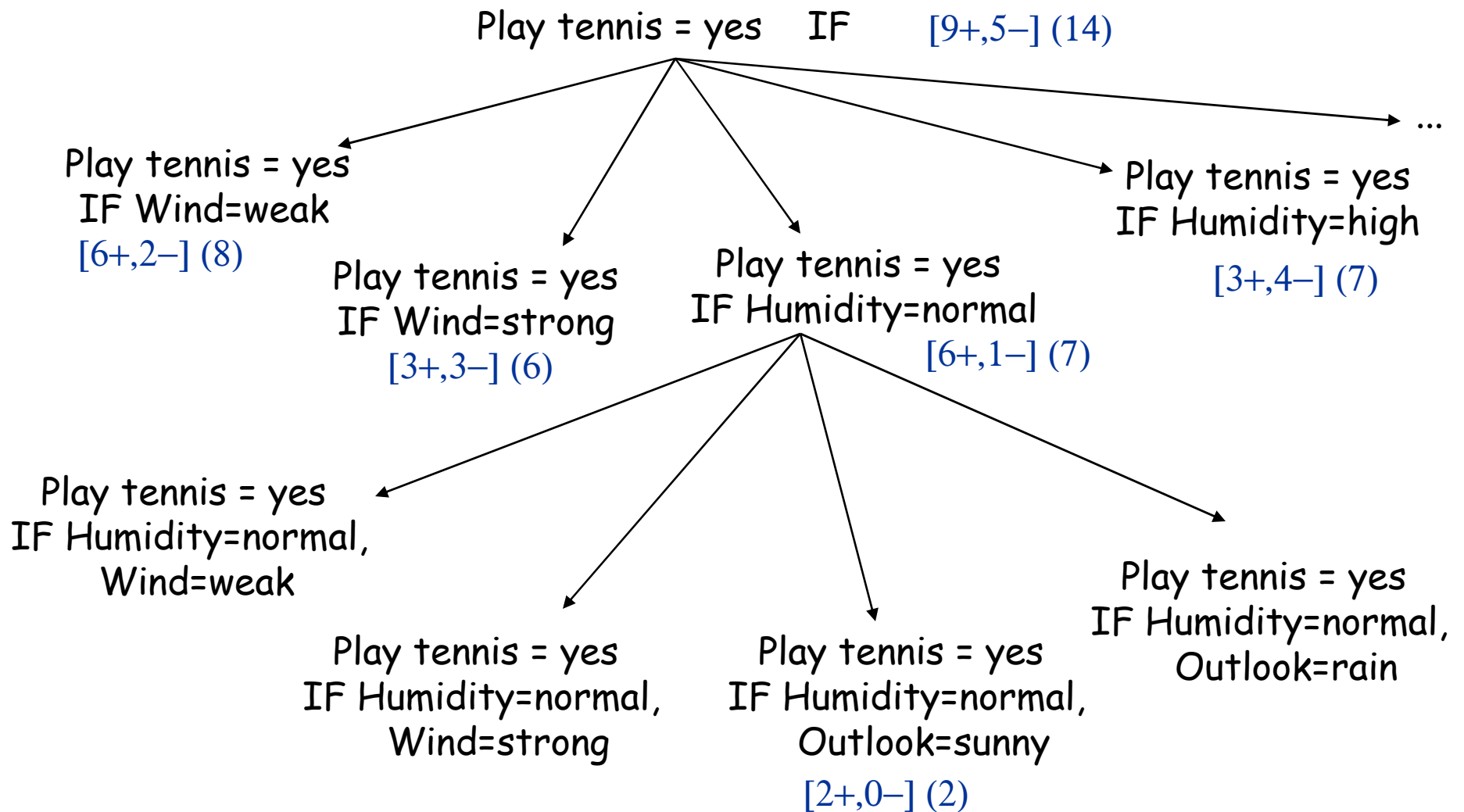

# What is “high” rule accuracy (rule precision) ?

- Rule evaluation measures:
  - aimed at maximizing classification accuracy
  - minimizing Error = 1 - Accuracy
  - avoiding overfitting
- BUT: Rule accuracy/precision should be traded off against the “default” accuracy/precision of the rule **CI ← true**
  - 68% accuracy is OK if there are 20% examples of that class in the training set, but bad if there are 80%
- **Relative accuracy**
  - $\text{RAcc}(\text{CI} \leftarrow \text{Cond}) = p(\text{CI} \mid \text{Cond}) - p(\text{CI})$

# Weighted relative accuracy

- If a rule covers a single example, its accuracy/precision is either 0% or 100%
  - maximising relative accuracy tends to produce many overly specific rules
- **Weighted relative accuracy**  
$$\text{WRAcc}(\text{CI} \leftarrow \text{Cond}) = p(\text{Cond}) \cdot [p(\text{CI} \mid \text{Cond}) - p(\text{CI})]$$
- WRAcc is a fundamental rule evaluation measure:
  - WRAcc can be used if you want to assess both accuracy and significance
  - WRAcc can be used if you want to compare rules with different heads **and** bodies

# Learn-one-rule: search heuristics

- Assume two classes (+,-), learn rules for + class (Cl). Search for specializations of one rule  $R = Cl \leftarrow Cond$  from RuleBase.
- Expected **classification accuracy**:  $A(R) = p(Cl|Cond)$
- **Informativity** (info needed to specify that example covered by Cond belongs to Cl):  $I(R) = -\log_2 p(Cl|Cond)$
- **Accuracy gain** (increase in expected accuracy):  
 $AG(R',R) = p(Cl|Cond') - p(Cl|Cond)$
- **Information gain** (decrease in the information needed):  
 $IG(R',R) = \log_2 p(Cl|Cond') - \log_2 p(Cl|Cond)$
- **Weighted** measures favoring more general rules: WAG, WIG  
 $WAG(R',R) =$   
 $p(Cond')/p(Cond) \cdot (p(Cl|Cond') - p(Cl|Cond))$
- **Weighted relative accuracy** trades off coverage and relative accuracy  $WRAcc(R) = p(Cond) \cdot (p(Cl|Cond) - p(Cl))$

# Ordered set of rules: if-then-else rules

- rule Class IF Conditions is learned by first determining Conditions and then Class
- **Notice:** mixed sequence of classes  $C_1, \dots, C_n$  in RuleBase
- **But: ordered** execution when classifying a new instance: rules are sequentially tried and the first rule that `fires' (covers the example) is used for classification
- **Decision list**  $\{R_1, R_2, R_3, \dots, D\}$ : rules  $R_i$  are interpreted as **if-then-else** rules
- If no rule fires, then DefaultClass (majority class in  $E_{cur}$ )



# Sequential covering algorithm (similar as in Mitchell's book)

- RuleBase := empty
- $E_{\text{cur}} := E$
- **repeat**
  - learn-one-rule R
  - RuleBase := RuleBase U R
  - $E_{\text{cur}} := E_{\text{cur}} - \{\text{examples covered and correctly classified by R}\}$  **(DELETE ONLY POS. EX.!)**
  - **until** performance(R,  $E_{\text{cur}}$ ) < ThresholdR
- RuleBase := sort RuleBase by performance(R,E)
- return RuleBase

# Learn ordered set of rules (CN2, Clark and Niblett 1989)

- RuleBase := empty
- $E_{\text{cur}} := E$
- **repeat**
  - learn-one-rule R
  - RuleBase := RuleBase U R
  - $E_{\text{cur}} := E_{\text{cur}} - \{\text{all examples covered by R}\}$   
**(NOT ONLY POS. EX.!)**
- **until** performance(R,  $E_{\text{cur}}$ ) < ThresholdR
- RuleBase := sort RuleBase by performance(R, E)
- RuleBase := RuleBase U DefaultRule( $E_{\text{cur}}$ )

# Learn-one-rule: Beam search in CN2

- Beam search in CN2 learn-one-rule algo.:
  - construct BeamSize of best rule bodies (conjunctive conditions) that are statistically significant
  - BestBody - min. entropy of examples covered by Body
  - construct best rule  $R := \text{Head} \leftarrow \text{BestBody}$  by adding majority class of examples covered by BestBody in rule Head
- performance  $(R, E_{\text{cur}}) : - \text{Entropy}(E_{\text{cur}})$ 
  - performance  $(R, E_{\text{cur}}) < \text{ThresholdR}$  (neg. num.)
  - Why? Ent.  $> t$  is bad, Perf. =  $-\text{Ent} < -t$  is bad

# Variations

- Sequential vs. simultaneous covering of data (as in TDIDT): choosing between attribute-values vs. choosing attributes
- Learning rules vs. learning decision trees and converting them to rules
- Pre-pruning vs. post-pruning of rules
- What statistical evaluation functions to use
- Probabilistic classification

# Probabilistic classification

- In the ordered case of standard CN2 rules are interpreted in an IF-THEN-ELSE fashion, and the first fired rule assigns the class.
- In the unordered case all rules are tried and all rules which fire are collected. If a clash occurs, a probabilistic method is used to resolve the clash.
- A simplified example:
  1. tear production=reduced => lenses=NONE [S=0,H=0,N=12]
  2. tear production=normal & astigmatism=yes & spect. pre.=hypermetrope => lenses=NONE [S=0,H=1,N=2]
  3. tear production=normal & astigmatism=no => lenses=SOFT [S=5,H=0,N=1]
  4. tear production=normal & astigmatism=yes & spect. pre.=myope => lenses=HARD [S=0,H=3,N=2]
  5. DEFAULT lenses=NONE

Suppose we want to classify a person with normal tear production and astigmatism. Two rules fire: rule 2 with coverage [S=0,H=1,N=2] and rule 4 with coverage [S=0,H=3,N=2]. The classifier computes total coverage as [S=0,H=4,N=4], resulting in probabilistic classification into class H with probability 0.5 and N with probability 0.5. In this case, the clash can not be resolved, as both probabilities are equal.

## Part II. Predictive DM techniques

- Naïve Bayesian classifier
- Decision tree learning
- Classification rule learning
- Classifier evaluation

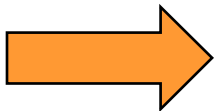

# Classifier evaluation

- Accuracy and Error
- n-fold cross-validation
- Confusion matrix
- ROC

# Evaluating hypotheses

- **Use of induced hypotheses**
  - discovery of new patterns, new knowledge
  - classification of new objects
- **Evaluating the quality of induced hypotheses**
  - Accuracy, Error =  $1 - \text{Accuracy}$
  - classification accuracy on testing examples = percentage of correctly classified instances
    - split the example set into training set (e.g. 70%) to induce a concept, and test set (e.g. 30%) to test its accuracy
    - more elaborate strategies: 10-fold cross validation, leave-one-out, ...
  - comprehensibility (compactness)
  - information contents (information score), significance



# n-fold cross validation

- A method for accuracy estimation of classifiers
- Partition set  $D$  into  $n$  disjoint, almost equally-sized folds  $T_i$  where  $\bigcup_i T_i = D$
- **for**  $i = 1, \dots, n$  **do**
  - form a training set out of  $n-1$  folds:  $D_i = D \setminus T_i$
  - induce classifier  $H_i$  from examples in  $D_i$
  - use fold  $T_i$  for testing the accuracy of  $H_i$
- Estimate the accuracy of the classifier by averaging accuracies over  $n$  folds  $T_i$

• Partition

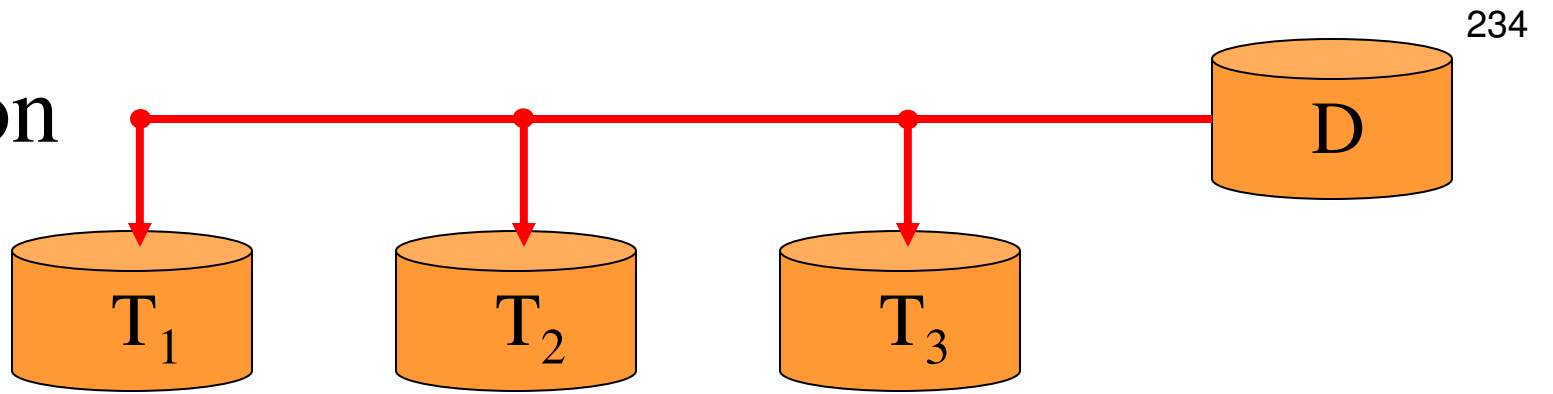

•Partition

•Train

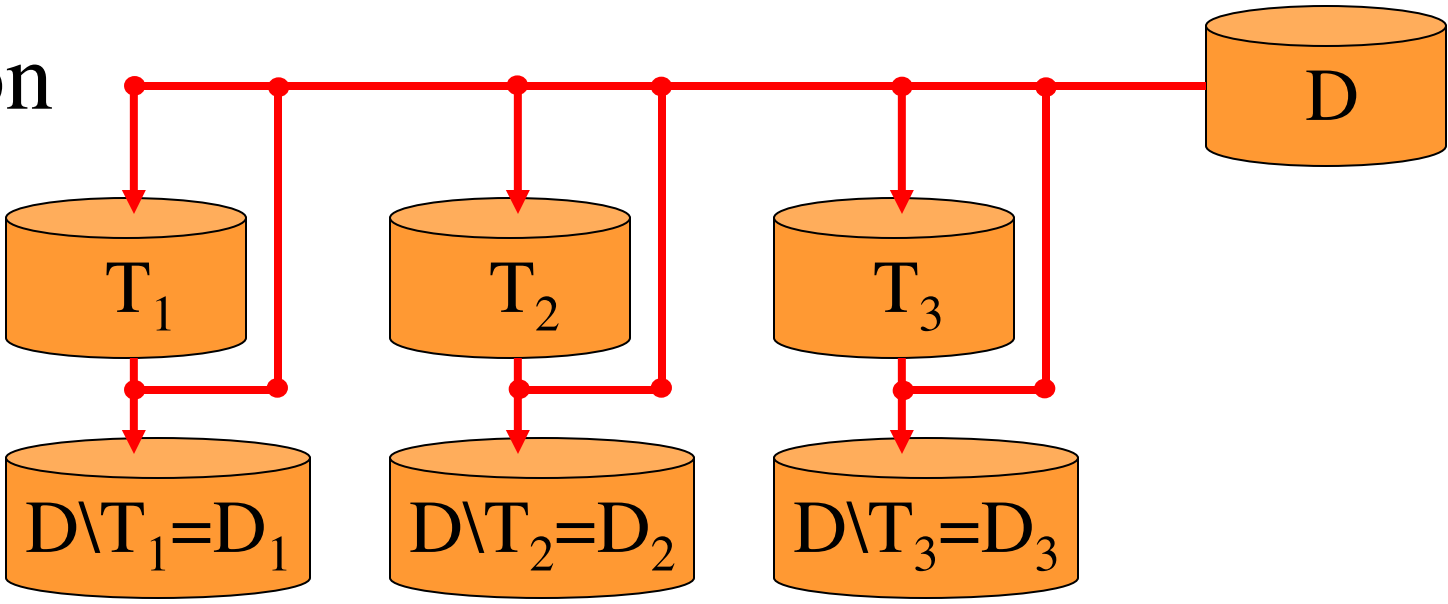

•Partition

•Train

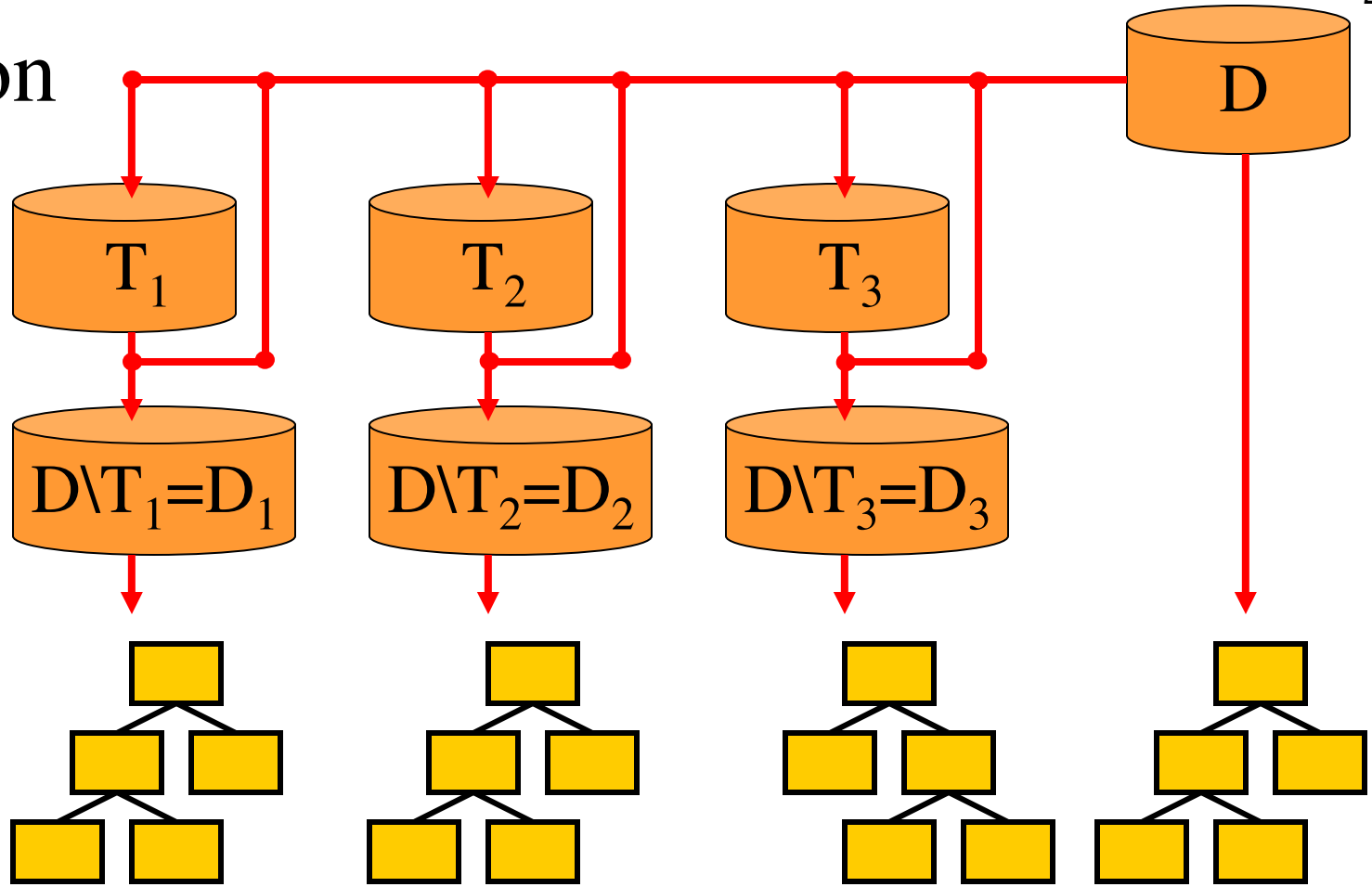

•Partition

•Train

•Test

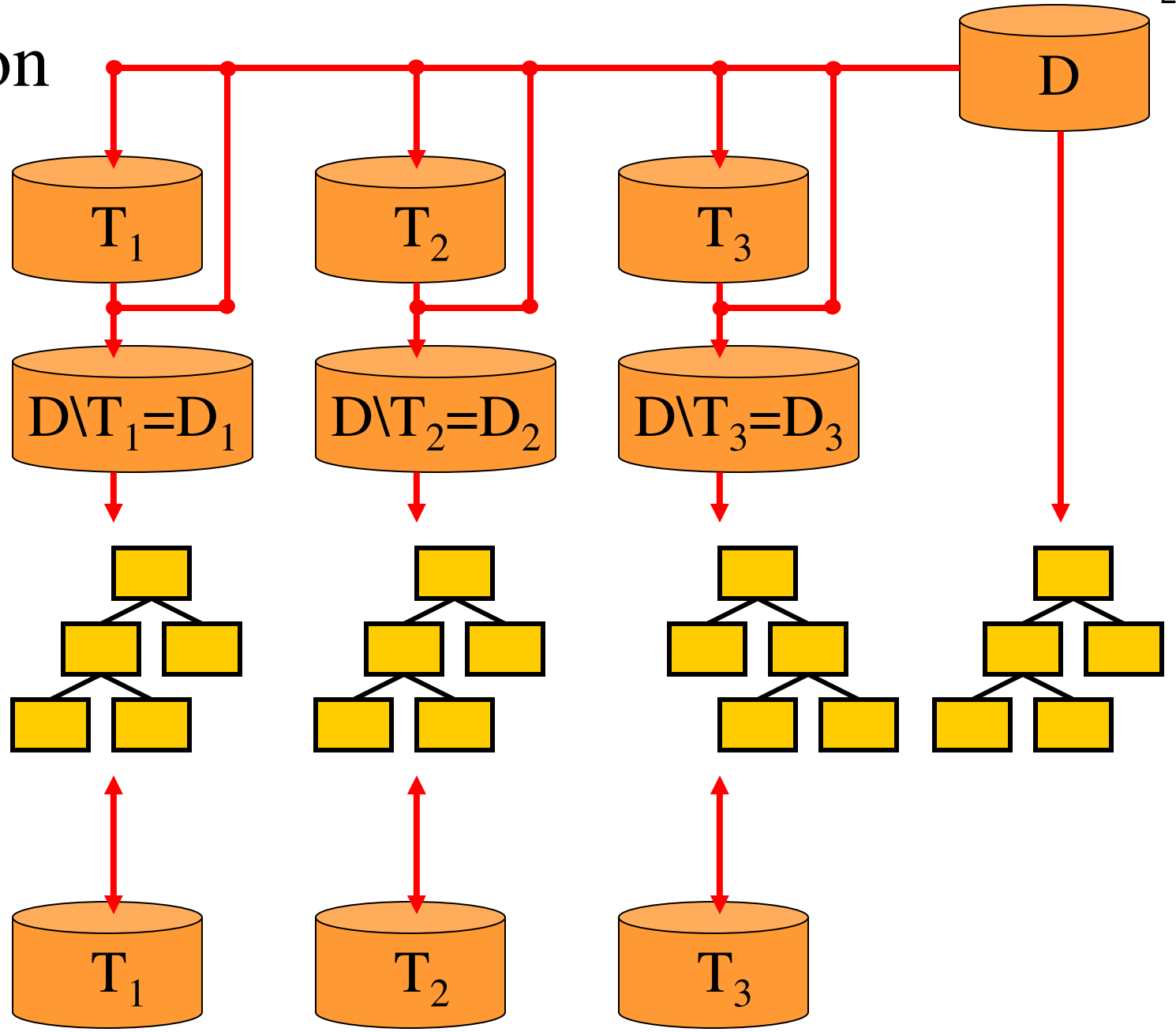

# Confusion matrix and rule (in)accuracy

- Accuracy of a classifier is measured as  $TP+TN / N$ .
- Suppose two rules are both 80% accurate on an evaluation dataset, are they always equally good?
  - e.g., Rule 1 correctly classifies 40 out of 50 positives and 40 out of 50 negatives; Rule 2 correctly classifies 30 out of 50 positives and 50 out of 50 negatives
  - on a test set which has more negatives than positives, Rule 2 is preferable;
  - on a test set which has more positives than negatives, Rule 1 is preferable; unless...
  - ...the proportion of positives becomes so high that the 'always positive' predictor becomes superior!
- Conclusion: classification accuracy is not always an appropriate rule quality measure

# Confusion matrix

	Predicted positive	Predicted negative	
Positive examples	<b>True positives</b>	<b>False negatives</b>	
Negative examples	<b>False positives</b>	<b>True negatives</b>	

- also called *contingency table*

Classifier 1			
	Predicted positive	Predicted negative	
Positive examples	<b>40</b>	<b>10</b>	50
Negative examples	<b>10</b>	<b>40</b>	50
	50	50	100

Classifier 2			
	Predicted positive	Predicted negative	
Positive examples	<b>30</b>	<b>20</b>	50
Negative examples	<b>0</b>	<b>50</b>	50
	30	70	100

# ROC space

- **True positive rate** =  
#true pos. / #pos.
  - $TPr_1 = 40/50 = 80\%$
  - $TPr_2 = 30/50 = 60\%$
- **False positive rate**  
= #false pos. / #neg.
  - $FPr_1 = 10/50 = 20\%$
  - $FPr_2 = 0/50 = 0\%$
- **ROC space** has
  - FPr on X axis
  - TPr on Y axis

Classifier 1			
	Predicted positive	Predicted negative	
Positive examples	40	10	50
Negative examples	10	40	50
	50	50	100

Classifier 2			
	Predicted positive	Predicted negative	
Positive examples	30	20	50
Negative examples	0	50	50
	30	70	100

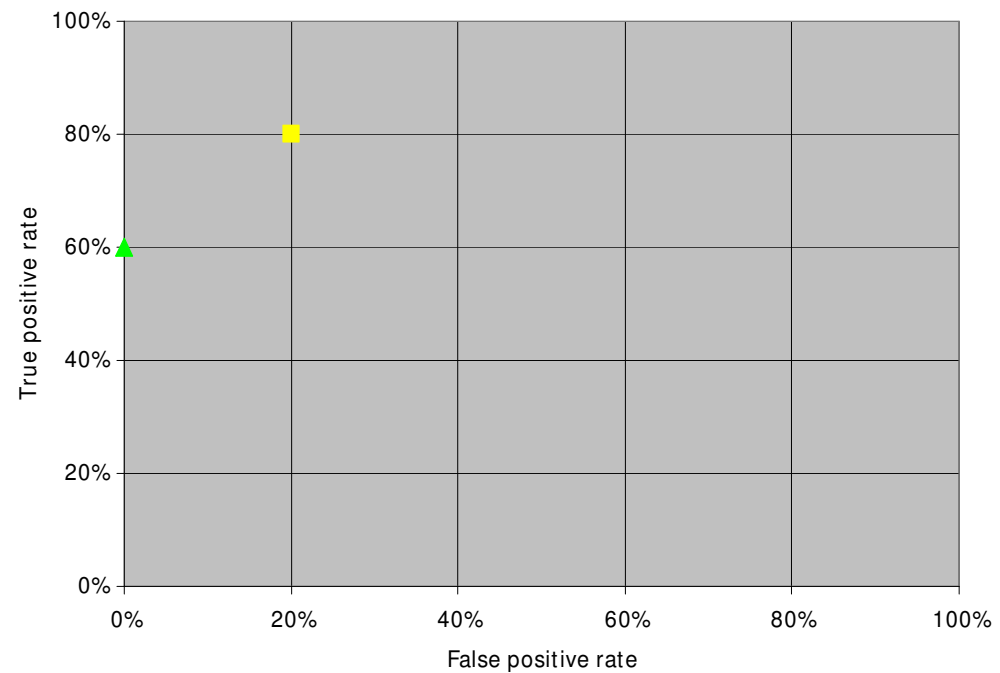



# The ROC space

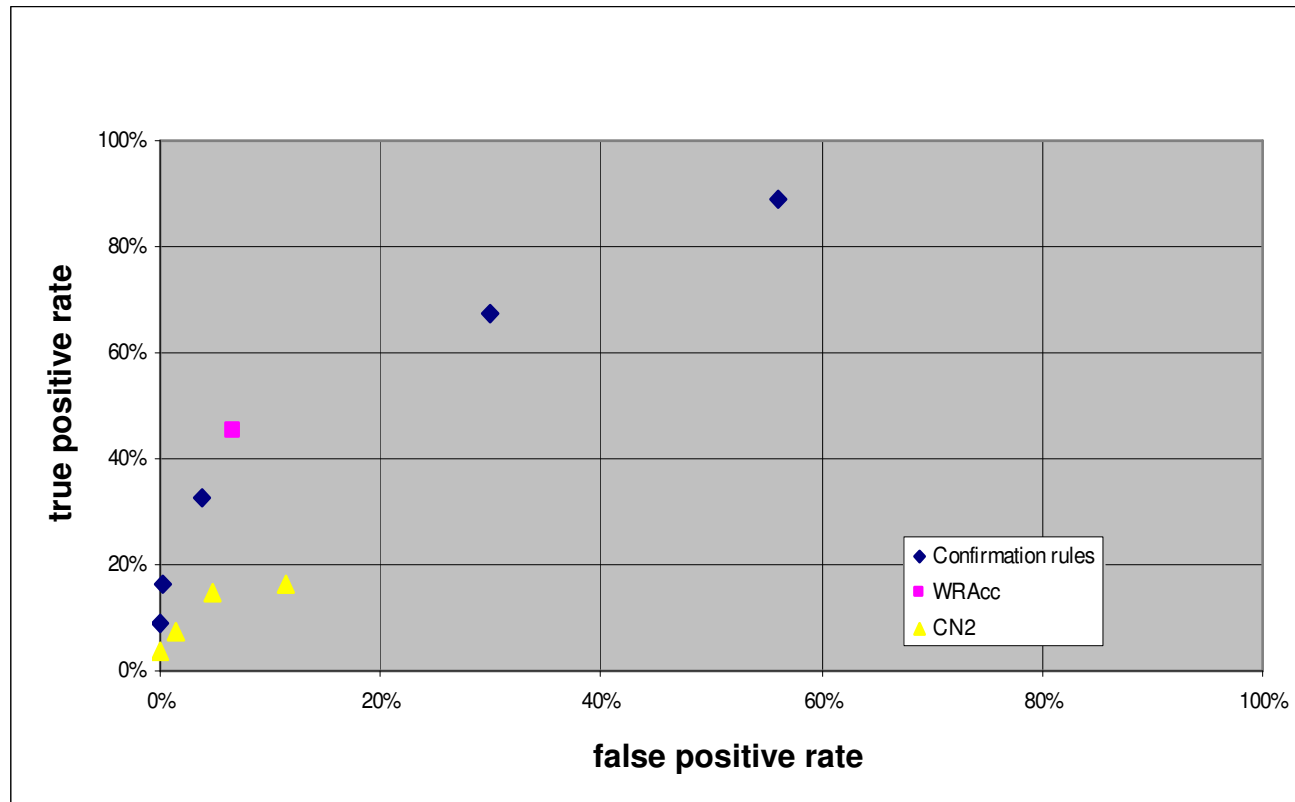

# The ROC convex hull

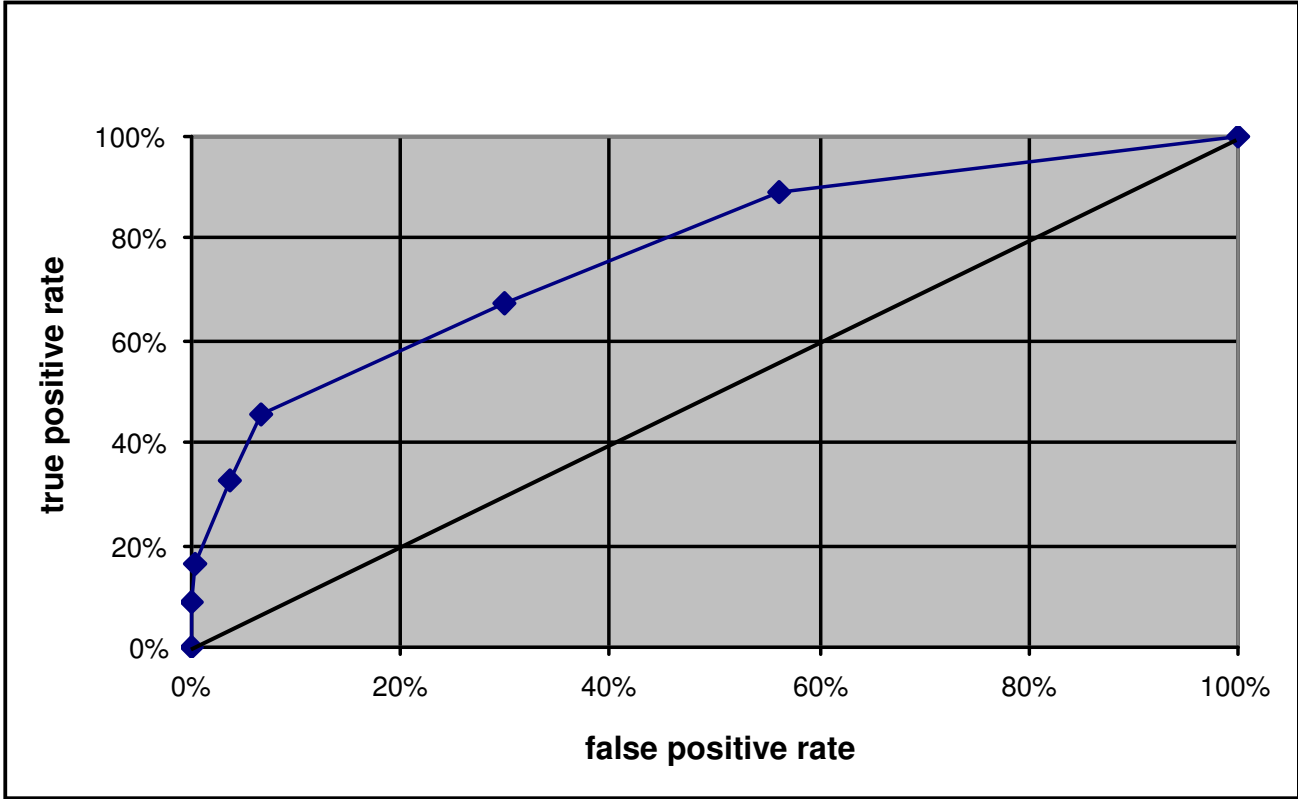

# Summary of evaluation

- 10-fold cross-validation is a standard classifier evaluation method used in machine learning
- ROC analysis is very natural for rule learning and subgroup discovery
  - can take costs into account
  - here used for evaluation
  - also possible to use as search heuristic

# Part III. Numeric prediction

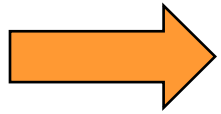

- Baseline
- Linear Regression
- Regression tree
- Model Tree
- kNN

<b>Regression</b>	<b>Classification</b>
<b>Data:</b> attribute-value description	
<b>Target variable:</b> Continuous	<b>Target variable:</b> Categorical (nominal)
<b>Evaluation:</b> cross validation, separate test set, ...	
<b>Error:</b> MSE, MAE, RMSE, ...	<b>Error:</b> 1-accuracy
<b>Algorithms:</b> Linear regression, regression trees,...	<b>Algorithms:</b> Decision trees, Naïve Bayes, ...
<b>Baseline predictor:</b> Mean of the target variable	<b>Baseline predictor:</b> Majority class

# Example

- data about 80 people: Age and Height

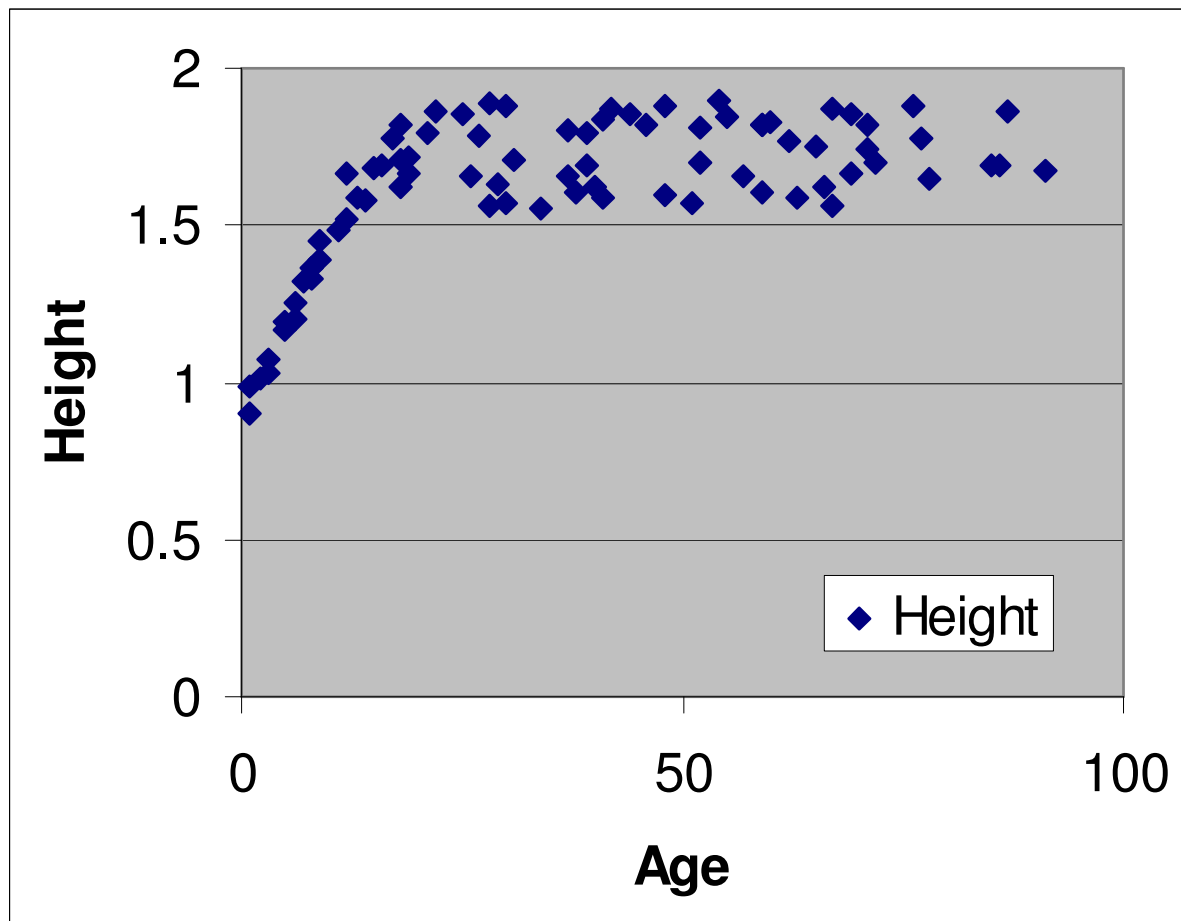

Age	Height
3	1.03
5	1.19
6	1.26
9	1.39
15	1.69
19	1.67
22	1.86
25	1.85
41	1.59
48	1.60
54	1.90
71	1.82
...	...

# Test set

Age	Height
2	0.85
10	1.4
35	1.7
70	1.6

# Baseline numeric predictor

- Average of the target variable

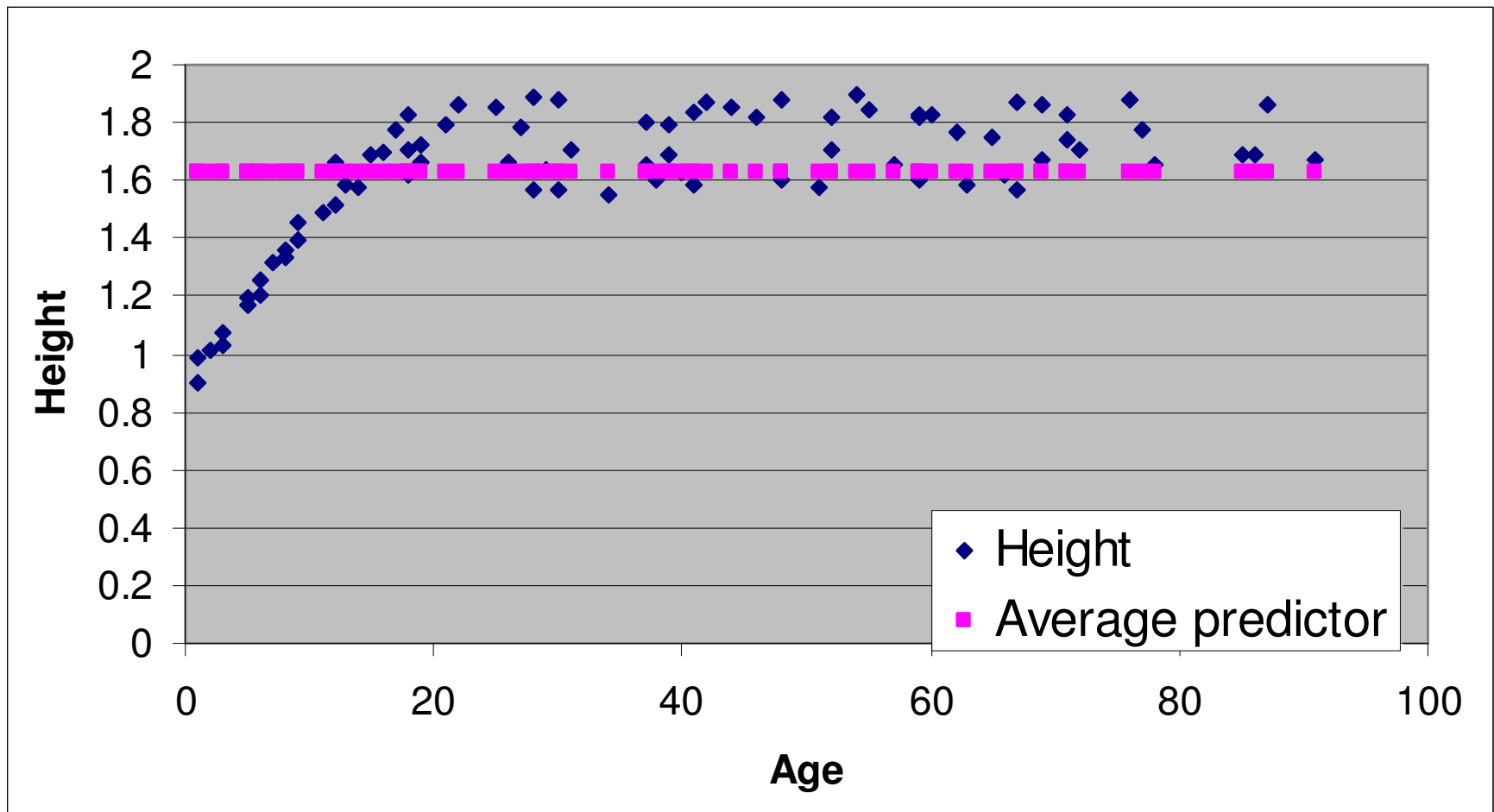



# Baseline predictor: prediction

Average of the target variable is 1.63

Age	Height	Baseline
2	0.85	
10	1.4	
35	1.7	
70	1.6	

# Linear Regression Model

$$\text{Height} = 0.0056 * \text{Age} + 1.4181$$

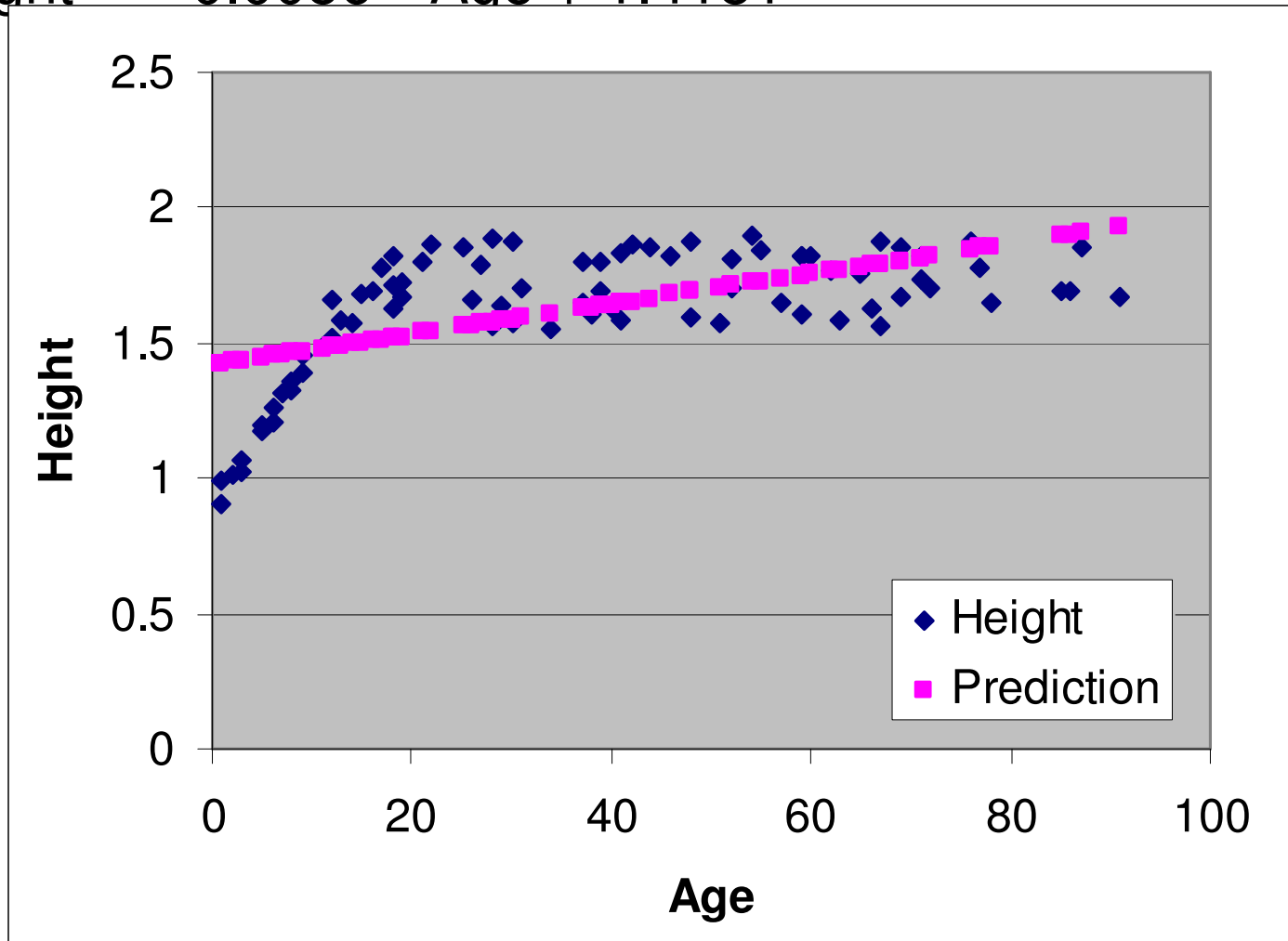

# Linear Regression: prediction

$$\text{Height} = 0.0056 * \text{Age} + 1.4181$$

Age	Height	Linear regression
2	0.85	
10	1.4	
35	1.7	
70	1.6	

# Regression tree

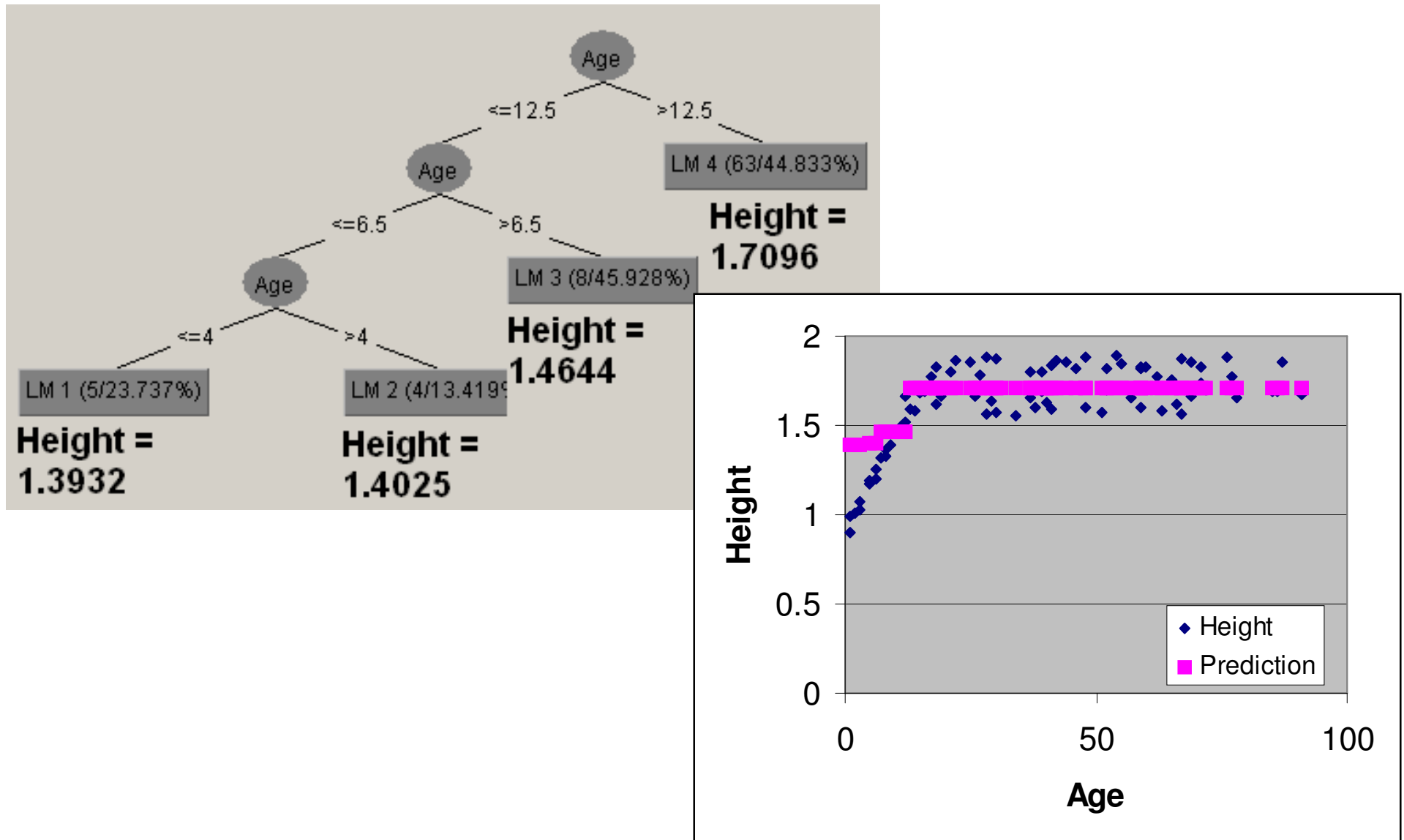

# Regression tree: prediction

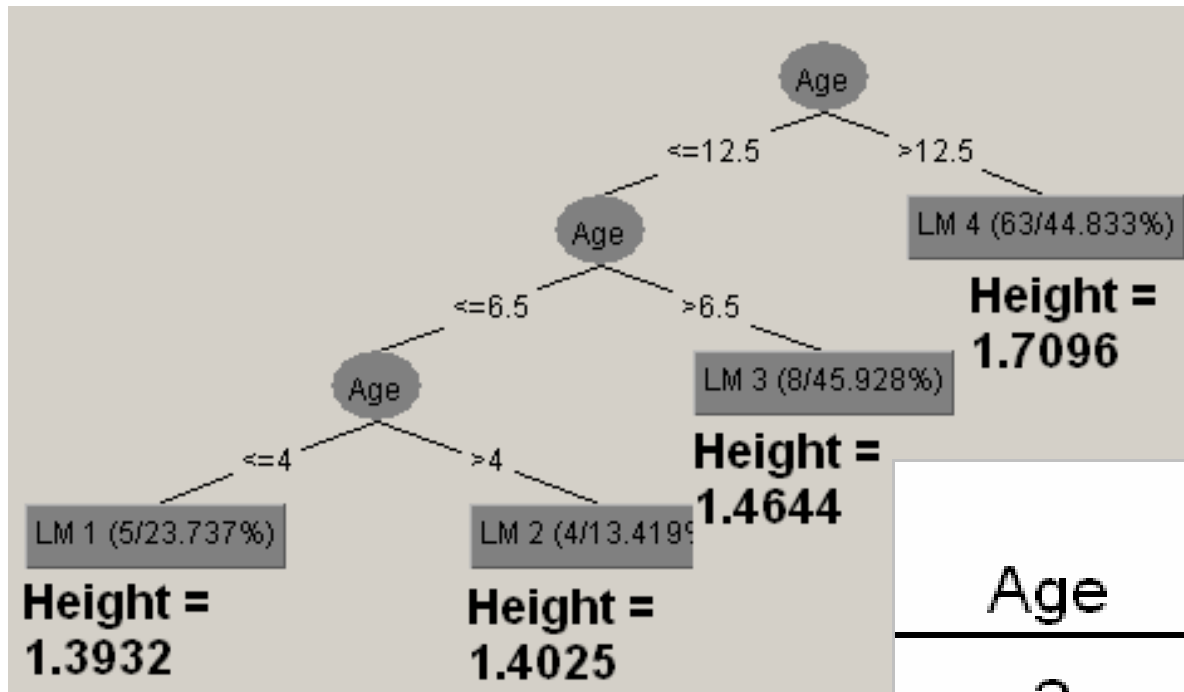

Age	Height	Regression tree
2	0.85	
10	1.4	
35	1.7	
70	1.6	

# Model tree

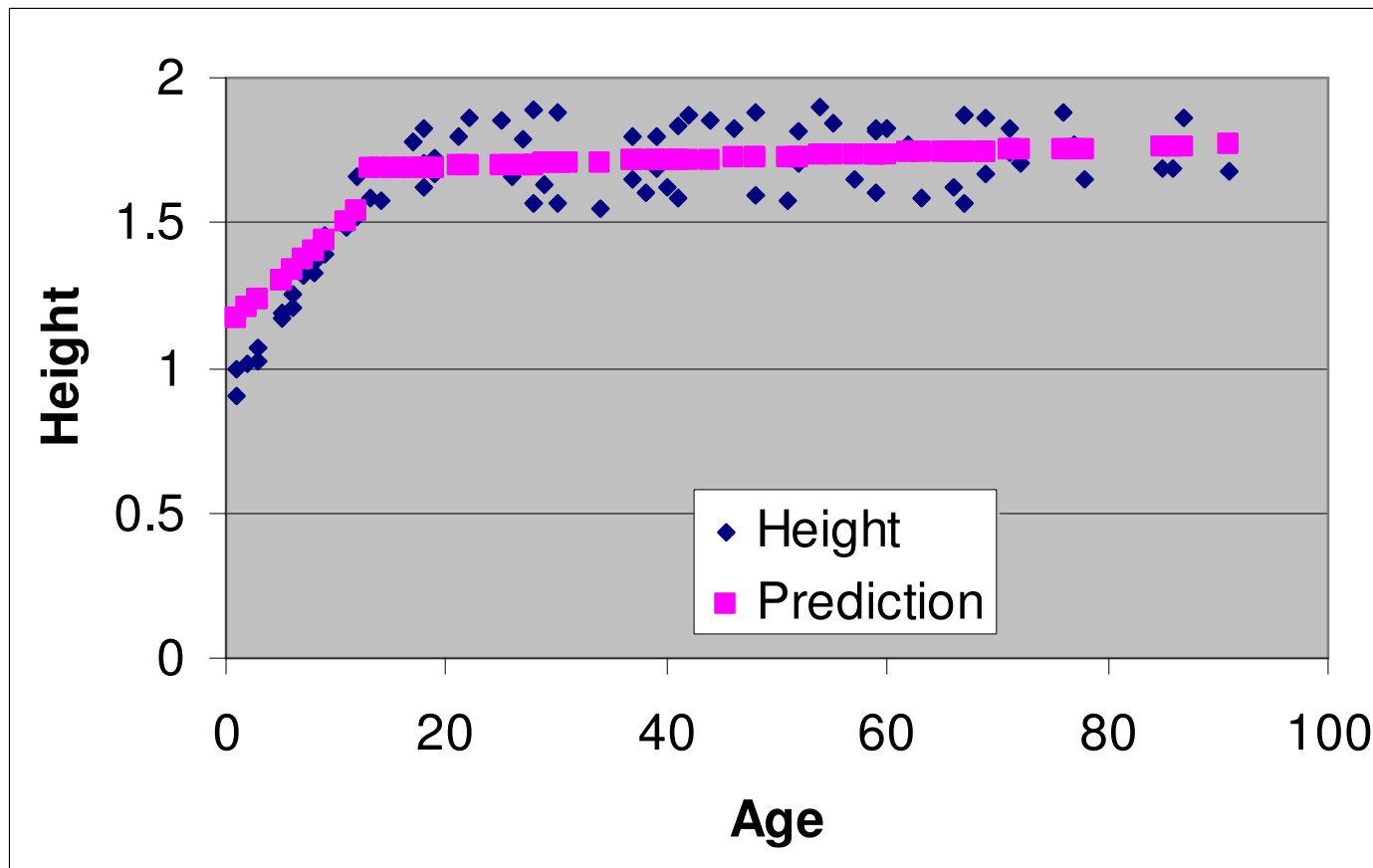

# Model tree: prediction

Age	Height	Model tree
2	0.85	
10	1.4	
35	1.7	
70	1.6	



# kNN – K nearest neighbors

- Looks at K closest examples (by age) and predicts the average of their target variable
- K=3

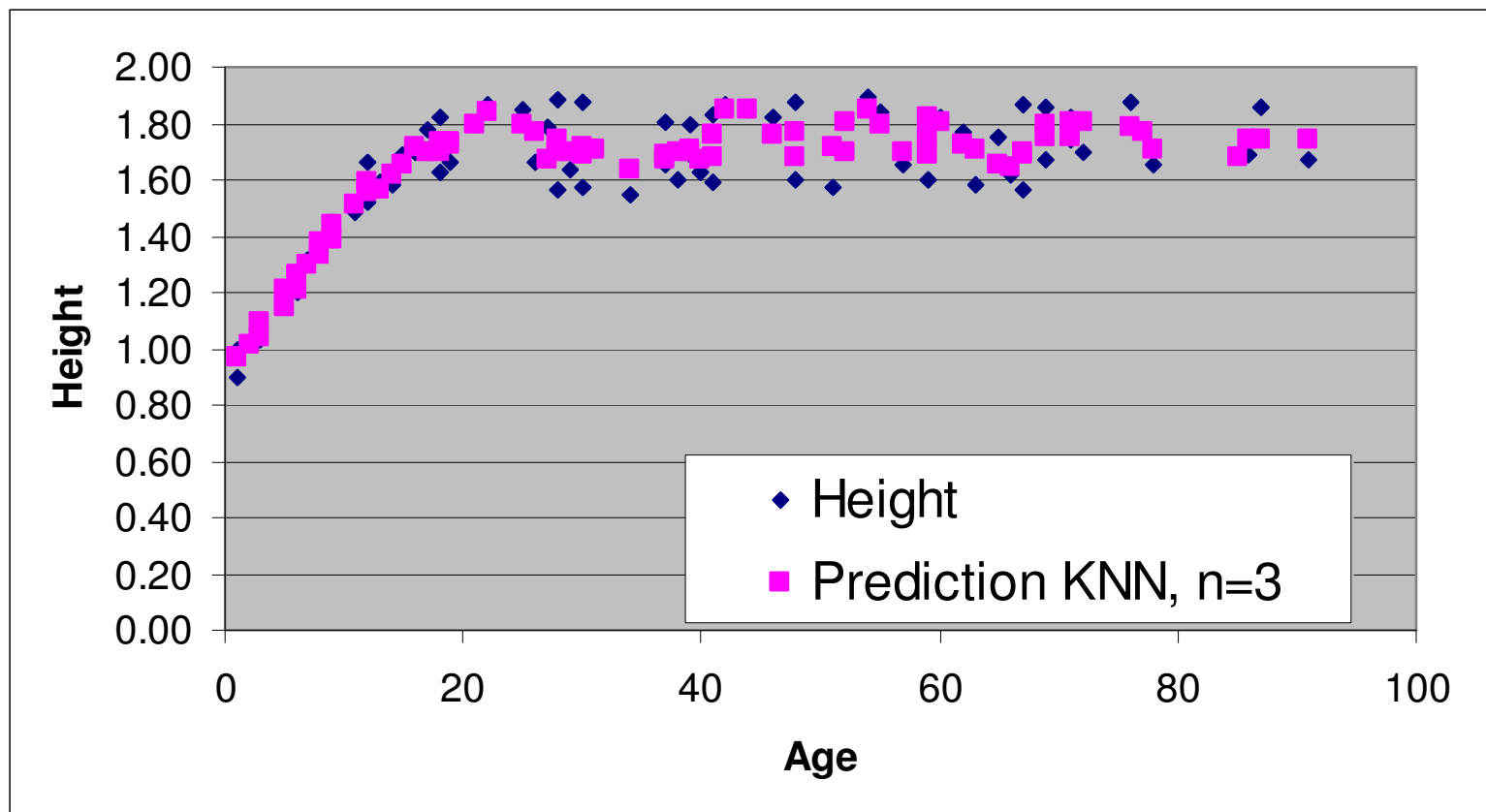



# kNN prediction

Age	Height
1	0.90
1	0.99
2	1.01
3	1.03
3	1.07
5	1.19
5	1.17

Age	Height	kNN
2	0.85	
10	1.4	
35	1.7	
70	1.6	

# kNN prediction

Age	Height
8	1.36
8	1.33
9	1.45
9	1.39
11	1.49
12	1.66
12	1.52
13	1.59
14	1.58

Age	Height	kNN
2	0.85	
10	1.4	
35	1.7	
70	1.6	

# kNN prediction

Age	Height
30	1.57
30	1.88
31	1.71
34	1.55
37	1.65
37	1.80
38	1.60
39	1.69
39	1.80

Age	Height	kNN
2	0.85	
10	1.4	
35	1.7	
70	1.6	

# kNN prediction

Age	Height
67	1.56
67	1.87
69	1.67
69	1.86
71	1.74
71	1.82
72	1.70
76	1.88

Age	Height	kNN
2	0.85	
10	1.4	
35	1.7	
70	1.6	

# Which predictor is the best?

Age	Height	Baseline	Linear regression	Regression tree	Model tree	kNN
2	0.85	1.63	1.43	1.39	1.20	1.01
10	1.4	1.63	1.47	1.46	1.47	1.51
35	1.7	1.63	1.61	1.71	1.71	1.67
70	1.6	1.63	1.81	1.71	1.75	1.81

# Evaluating numeric prediction

Performance measure	Formula
mean-squared error	$\frac{(p_1 - a_1)^2 + \dots + (p_n - a_n)^2}{n}$
root mean-squared error	$\sqrt{\frac{(p_1 - a_1)^2 + \dots + (p_n - a_n)^2}{n}}$
mean absolute error	$\frac{ p_1 - a_1  + \dots +  p_n - a_n }{n}$
relative squared error	$\frac{(p_1 - a_1)^2 + \dots + (p_n - a_n)^2}{(a_1 - \bar{a})^2 + \dots + (a_n - \bar{a})^2}, \text{ where } \bar{a} = \frac{1}{n} \sum_i a_i$
root relative squared error	$\sqrt{\frac{(p_1 - a_1)^2 + \dots + (p_n - a_n)^2}{(a_1 - \bar{a})^2 + \dots + (a_n - \bar{a})^2}}$
relative absolute error	$\frac{ p_1 - a_1  + \dots +  p_n - a_n }{ a_1 - \bar{a}  + \dots +  a_n - \bar{a} }$
correlation coefficient	$\frac{S_{PA}}{\sqrt{S_p S_A}}, \text{ where } S_{PA} = \frac{\sum_i (p_i - \bar{p})(a_i - \bar{a})}{n-1},$ $S_p = \frac{\sum_i (p_i - \bar{p})^2}{n-1}, \text{ and } S_A = \frac{\sum_i (a_i - \bar{a})^2}{n-1}$

## Part IV. Descriptive DM techniques

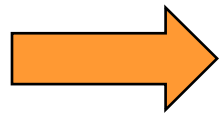

- Predictive vs. descriptive induction
- Subgroup discovery
- Association rule learning
- Hierarchical clustering

# Predictive vs. descriptive induction

- **Predictive induction:** Inducing classifiers for solving classification and prediction tasks,
  - Classification rule learning, Decision tree learning, ...
  - Bayesian classifier, ANN, SVM, ...
  - Data analysis through hypothesis generation and testing
- **Descriptive induction:** Discovering interesting regularities in the data, uncovering patterns, ... for solving KDD tasks
  - Symbolic clustering, Association rule learning, Subgroup discovery, ...
  - Exploratory data analysis



# Descriptive DM

- Often used for preliminary explanatory data analysis
- User gets feel for the data and its structure
- Aims at deriving descriptions of characteristics of the data
- Visualization and descriptive statistical techniques can be used

# Descriptive DM

- **Description**
  - **Data description and summarization**: describe elementary and aggregated data characteristics (statistics, ...)
  - **Dependency analysis**:
    - describe associations, dependencies, ...
    - discovery of properties and constraints
- **Segmentation**
  - **Clustering**: separate objects into subsets according to distance and/or similarity (clustering, SOM, visualization, ...)
  - **Subgroup discovery**: find unusual subgroups that are significantly different from the majority (deviation detection w.r.t. overall class distribution)

# Predictive vs. descriptive induction: A rule learning perspective

- **Predictive induction:** Induces **rulesets** acting as classifiers for solving classification and prediction tasks
- **Descriptive induction:** Discovers **individual rules** describing interesting regularities in the data
- **Therefore:** Different goals, different heuristics, different evaluation criteria

# Supervised vs. unsupervised learning: A rule learning perspective

- **Supervised learning:** Rules are induced from labeled instances (training examples with class assignment) - usually used in **predictive induction**
- **Unsupervised learning:** Rules are induced from unlabeled instances (training examples with no class assignment) - usually used in **descriptive induction**
- **Exception: Subgroup discovery**  
Discovers **individual rules** describing interesting regularities in the data from **labeled** examples

## Part IV. Descriptive DM techniques

- Predictive vs. descriptive induction
-  • Subgroup discovery
- Association rule learning
- Hierarchical clustering

# Subgroup Discovery

**Given:** a population of individuals and a target class label (the property of individuals we are interested in)

**Find:** population subgroups that are statistically most 'interesting', e.g., are as large as possible and have most unusual statistical (distributional) characteristics w.r.t. the target class (property of interest)

# Subgroup interestingness

## Interestingness criteria:

- As large as possible
- Class distribution as different as possible from the distribution in the entire data set
- Significant
- Surprising to the user
- Non-redundant
- Simple
- Useful - actionable

# Subgroup Discovery: Medical Case Study

- **Find and characterize population subgroups with high risk for coronary heart disease (CHD)** (Gamberger, Lavrač, Krstačić)
- **A1** for males: **principal risk factors**  
CHD ← pos. fam. history & age > 46
- **A2** for females: **principal risk factors**  
CHD ← bodyMassIndex > 25 & age > 63
- **A1, A2** (anamnestic info only), **B1, B2** (an. and physical examination), **C1** (an., phy. and ECG)
- **A1: supporting factors** (found by statistical analysis):  
psychosocial stress, as well as cigarette smoking, hypertension and overweight



# Subgroup visualization

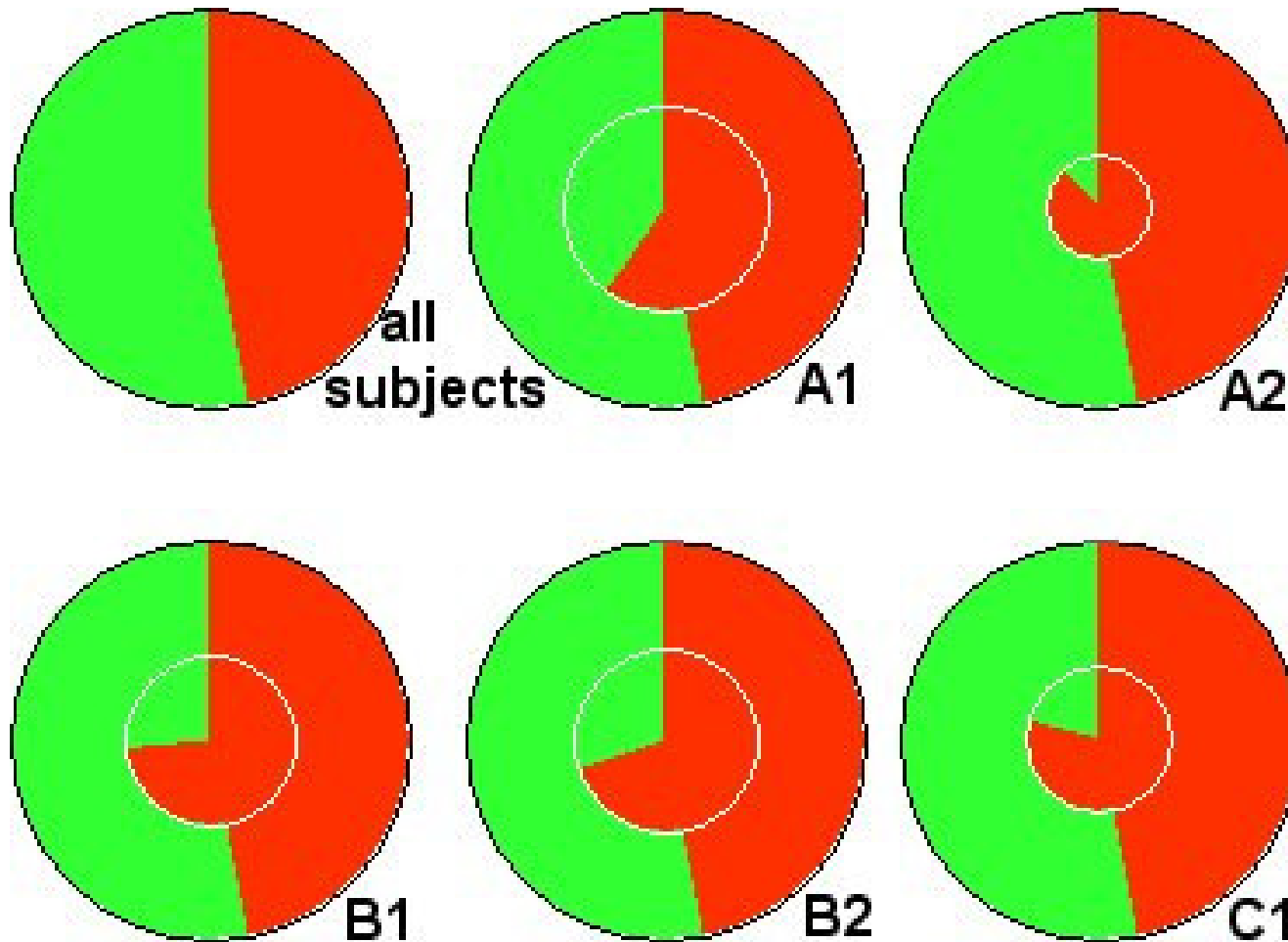

Subgroups of patients with CHD risk

[Gamberger, Lavrač & Wettschereck, IDAMAP2002]

# Subgroups vs. classifiers

- Classifiers:
  - Classification rules aim at pure subgroups
  - A set of rules forms a domain model
- Subgroups:
  - Rules describing subgroups aim at significantly higher proportion of positives
  - Each rule is an independent chunk of knowledge
- Link
  - SD can be viewed as cost-sensitive classification
  - Instead of  $FN_{cost}$  we aim at increased  $TP_{profit}$

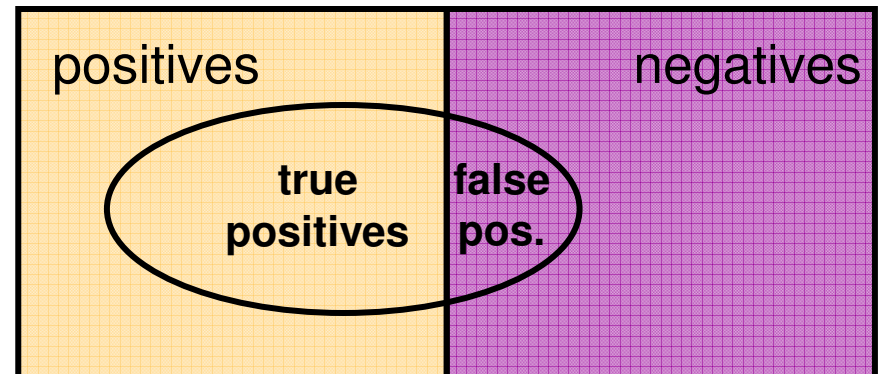

# Classification Rule Learning for Subgroup Discovery: Deficiencies

- Only first few rules induced by the covering algorithm have sufficient support (coverage)
- Subsequent rules are induced from smaller and strongly biased example subsets (pos. examples not covered by previously induced rules), which hinders their ability to detect population subgroups
- ‘Ordered’ rules are induced and interpreted sequentially as a **if-then-else** decision list

# CN2-SD: Adapting CN2 Rule Learning to Subgroup Discovery

- Weighted covering algorithm
- Weighted relative accuracy (WRAcc) search heuristics, with added example weights
- Probabilistic classification
- Evaluation with different interestingness measures

# CN2-SD: CN2 Adaptations

- General-to-specific search (beam search) for best rules
- Rule quality measure:
  - CN2: Laplace:  $\text{Acc}(\text{Class} \leftarrow \text{Cond}) =$   
 $= p(\text{Class}|\text{Cond}) = (n_c + 1) / (n_{\text{rule}} + k)$
  - CN2-SD: **Weighted Relative Accuracy**  
 $\text{WRAcc}(\text{Class} \leftarrow \text{Cond}) =$   
 $p(\text{Cond}) (p(\text{Class}|\text{Cond}) - p(\text{Class}))$
- **Weighted** covering approach (**example weights**)
- Significance testing (likelihood ratio statistics)
- Output: Unordered rule sets (**probabilistic classification**)

# CN2-SD: Weighted Covering

- Standard covering approach:  
covered examples are **deleted** from current training set
- **Weighted covering approach:**
  - weights assigned to examples
  - covered pos. examples are **re-weighted:**  
in all covering loop iterations, store  
count  $i$  how many times (with how many  
rules induced so far) a pos. example has  
been covered:  $w(e,i)$ ,  $w(e,0)=1$ 
    - **Additive weights:**  $w(e,i) = 1/(i+1)$   
 $w(e,i)$  – pos. example  $e$  being covered  $i$  times

# Subgroup Discovery

Positive examples

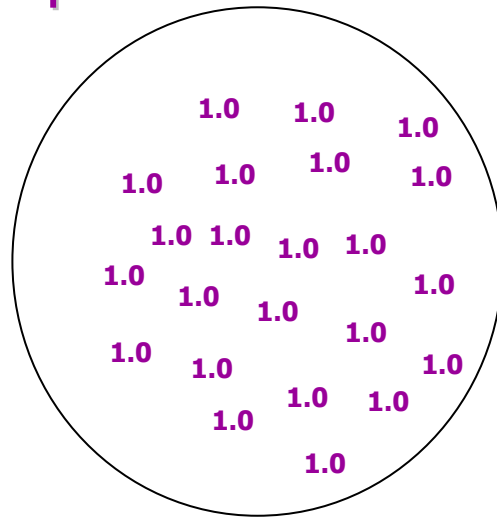

Negative examples

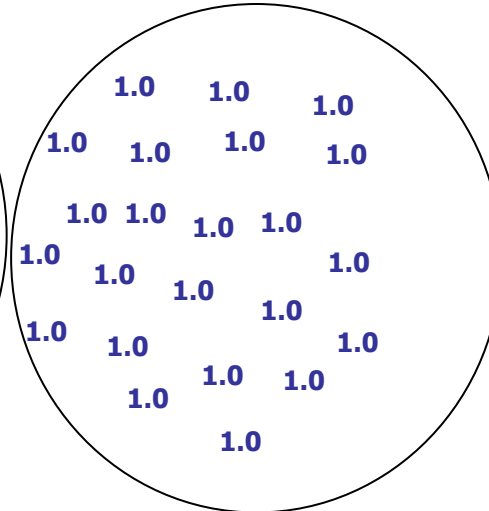

# Subgroup Discovery

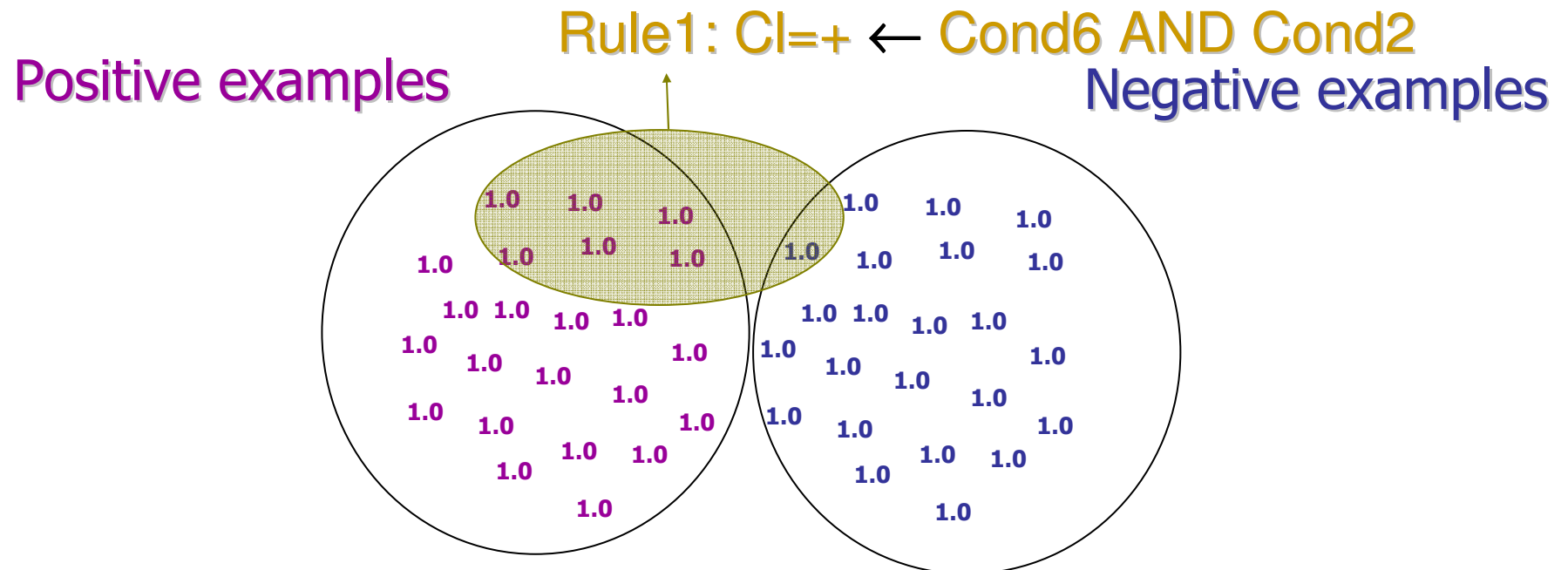



# Subgroup Discovery

Positive examples

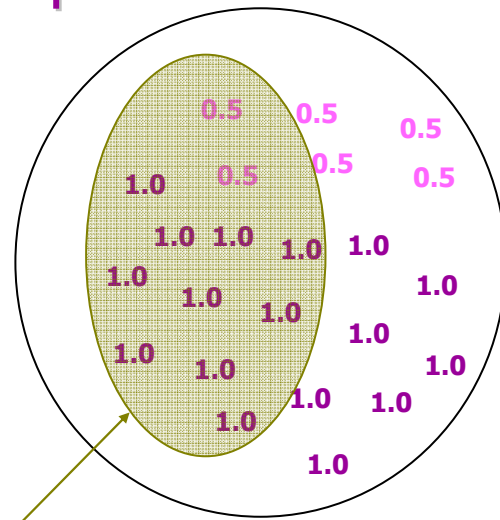

Negative examples

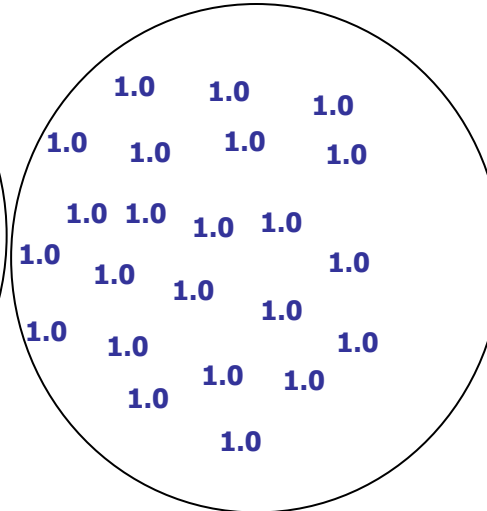

Rule2: Cl=+ ← Cond3 AND Cond4

# Subgroup Discovery

Positive examples

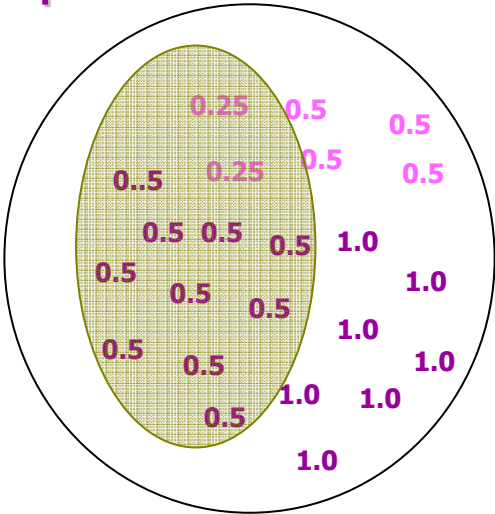

Negative examples

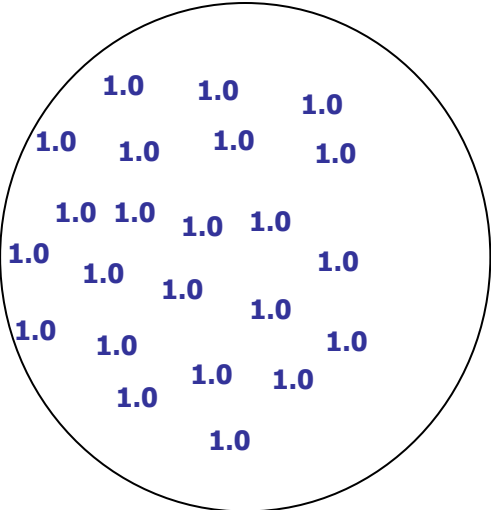

# CN2-SD: Weighted WRAcc Search Heuristic

- **Weighted relative accuracy (WRAcc) search heuristics, with added example weights**

$$\text{WRAcc}(\text{CI} \leftarrow \text{Cond}) = p(\text{Cond}) (p(\text{CI}|\text{Cond}) - p(\text{CI}))$$

increased coverage, decreased # of rules, approx. equal accuracy (PKDD-2000)

- In WRAcc computation, probabilities are estimated with relative frequencies, adapt:

$$\text{WRAcc}(\text{CI} \leftarrow \text{Cond}) = p(\text{Cond}) (p(\text{CI}|\text{Cond}) - p(\text{CI})) = \\ n'(\text{Cond})/N' ( n'(\text{CI}.\text{Cond})/n'(\text{Cond}) - n'(\text{CI})/N' )$$

- $N'$  : sum of weights of examples
- $n'(\text{Cond})$  : sum of weights of all covered examples
- $n'(\text{CI}.\text{Cond})$  : sum of weights of all correctly covered examples

## Part IV. Descriptive DM techniques

- Predictive vs. descriptive induction
- Subgroup discovery
- Association rule learning
- Hierarchical clustering

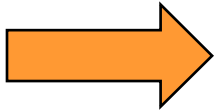

# Association Rule Learning

**Rules:**  $X \Rightarrow Y$ , if X then Y

X and Y are itemsets (records, conjunction of items), where items/features are binary-valued attributes)

**Given:** Transactions

	i1	i2	.....	i50
itemsets (records)	t1	1	1	0
	t2	0	1	0
	...	...	.....	...

**Find:** A set of association rules in the form  $X \Rightarrow Y$

**Example:** Market basket analysis

beer & coke  $\Rightarrow$  peanuts & chips (0.05, 0.65)

- Support:  $\text{Sup}(X, Y) = \#XY/\#D = p(XY)$
- Confidence:  $\text{Conf}(X, Y) = \#XY/\#X = \text{Sup}(X, Y)/\text{Sup}(X) = p(XY)/p(X) = p(Y|X)$

# Association Rule Learning: Examples

- Market basket analysis
  - beer & coke  $\Rightarrow$  peanuts & chips (5%, 65%)  
(IF beer AND coke THEN peanuts AND chips)
  - Support 5%: 5% of all customers buy all four items
  - Confidence 65%: 65% of customers that buy beer and coke also buy peanuts and chips
- Insurance
  - mortgage & loans & savings  $\Rightarrow$  insurance (2%, 62%)
  - Support 2%: 2% of all customers have all four
  - Confidence 62%: 62% of all customers that have mortgage, loan and savings also have insurance

# Association rule learning

- $X \Rightarrow Y$  . . . IF X THEN Y, where X and Y are itemsets
- intuitive meaning: transactions that contain X tend to contain Y
- **Items** - binary attributes (features) m,f,headache, muscle pain, arthrotic, arthritic, spondylotic, spondylitic, stiff\_less\_1\_hour
- **Example transactions** – itemsets formed of patient records

	i1	i2	.....	... i50
t1	1	0		0
t2	0	1		0
...	...	...		...

- **Association rules**

spondylitic  $\Rightarrow$  arthritic & stiff\_gt\_1\_hour [5%, 70%]

arthrotic & spondylotic  $\Rightarrow$  stiff\_less\_1\_hour [20%, 90%]

# Association Rule Learning

**Given:** a set of transactions  $D$

**Find:** all association rules that hold on the set of transactions that have

- user defined minimum support, i.e., support  $>$  **MinSup**, and
- user defined minimum confidence, i.e., confidence  $>$  **MinConf**

It is a form of exploratory data analysis, rather than hypothesis verification



# Searching for the associations

- Find all large itemsets
- Use the large itemsets to generate association rules
- If  $XY$  is a large itemset, compute
$$r = \text{support}(XY) / \text{support}(X)$$
- If  $r > \text{MinConf}$ , then  $X \Rightarrow Y$  holds  
(support  $>$  MinSup, as  $XY$  is large)

# Large itemsets

- Large itemsets are itemsets that appear in at least MinSup transaction
- All subsets of a large itemset are large itemsets (e.g., if A,B appears in at least MinSup transactions, so do A and B)
- This observation is the basis for very efficient algorithms for association rules discovery (linear in the number of transactions)

# Association vs. Classification rules

- Exploration of dependencies
  - Different combinations of dependent and independent attributes
  - Complete search (all rules found)
- Focused prediction
  - Predict one attribute (class) from the others
  - Heuristic search (subset of rules found)

## Part IV. Descriptive DM techniques

- Predictive vs. descriptive induction
- Subgroup discovery
- Association rule learning
- Hierarchical clustering

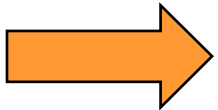

# Hierarchical clustering

- **Algorithm** (agglomerative hierarchical clustering):

Each instance is a cluster;

repeat

find **nearest** pair  $C_i$  in  $C_j$ ;

**fuse**  $C_i$  in  $C_j$  in a new cluster

$C_r = C_i \cup C_j$ ;

determine **dissimilarities** between

$C_r$  and other clusters;

until one cluster left;

- **Dendrogram:**

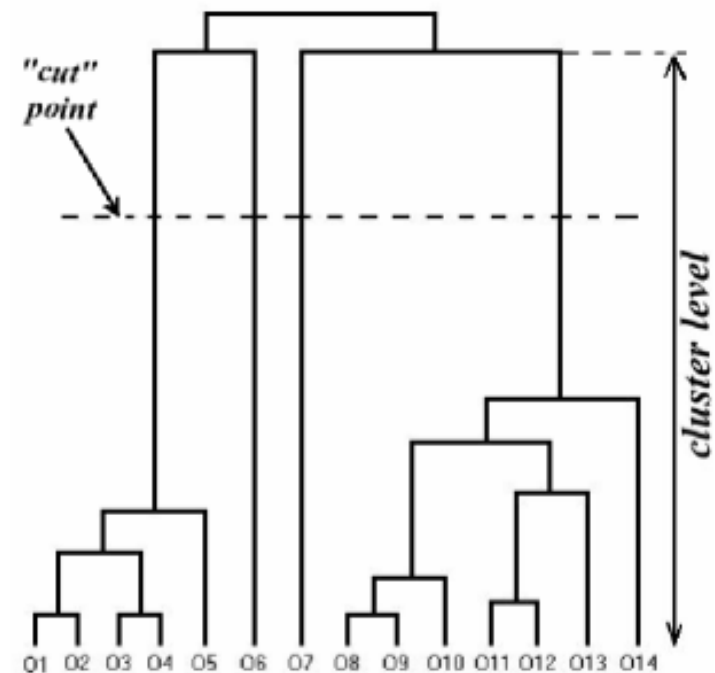

# Hierarchical clustering

- Fusing the nearest pair of clusters

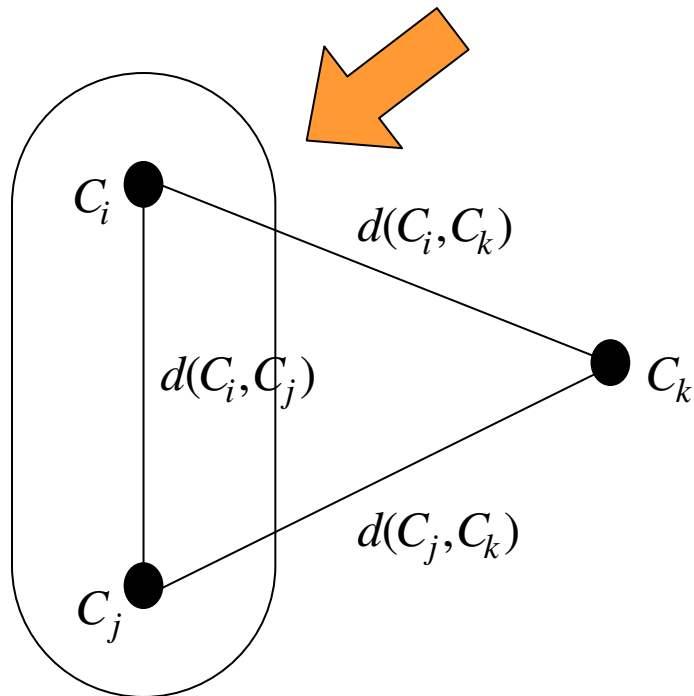

- Minimizing intra-cluster similarity
- Maximizing inter-cluster similarity

- Computing the dissimilarities from the “new” cluster

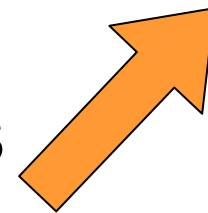

# Hierarchical clustering: example

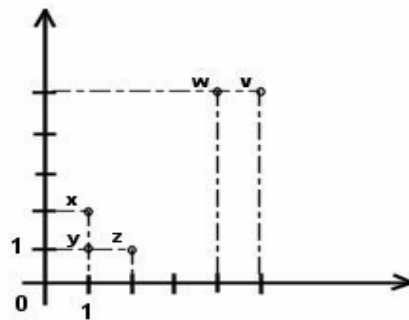

a) sample problem

	x	y	z	w	v
x	0	1	1	5	5.66
y		0	1.41	4.24	5
z			0	4.47	5
w				0	1
v					0

b) dissimilarity matrix

	(x,y)	z	w	v
(x,y)	0	1.41	5	5.66
z		0	4.47	5
w			0	1
v				0

c) dissimilarity matrix after 'fusing' elements **x** and **y**

	(x,y)	z	(w,v)
(x,y)	0	1.41	5.66
z		0	5
(w,v)			0

d) dissimilarity matrix after 'fusing' elements **w** and **v**

	(x,y,z)	(w,v)
(x,y,z)	0	5.66
(w,v)		0

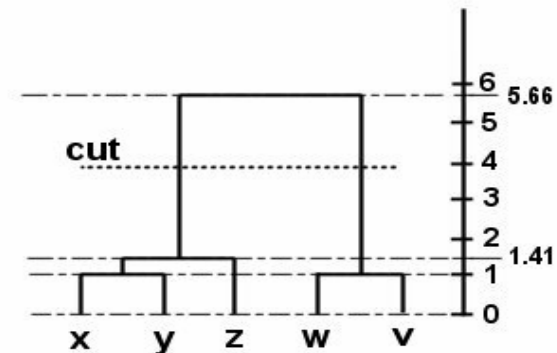
e) dissimilarity matrix after 'fusing' cluster **(x,y)** and element **z**

f) dendrogram

# Results of clustering

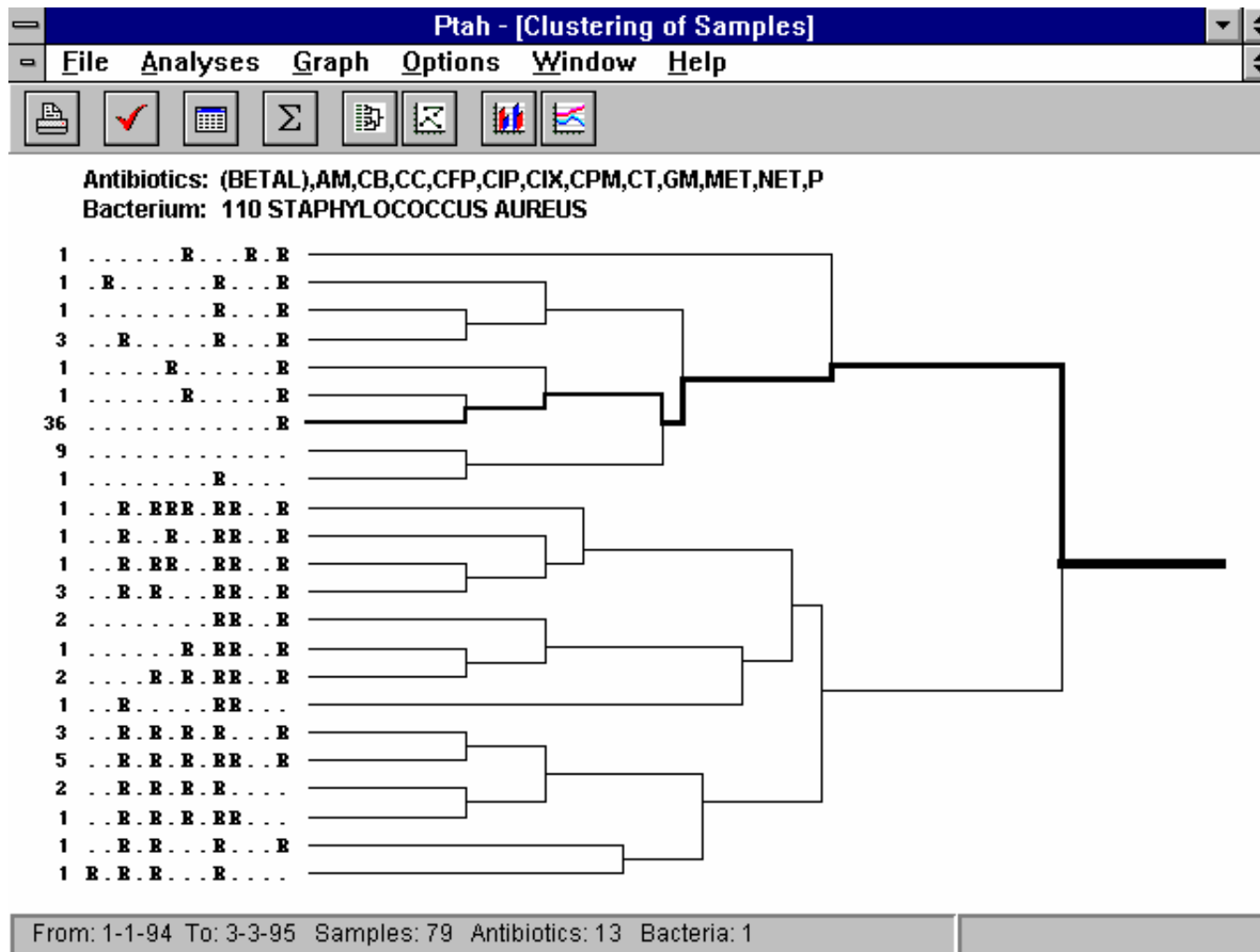

A dendrogram of resistance vectors

[Bohanec et al., "PTAH: A system for supporting nosocomial infection therapy", IDAMAP book, 1997]



# Part V:

## Relational Data Mining

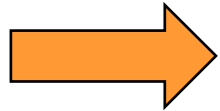

Learning as search

- What is RDM?
- Propositionalization techniques
- Inductive Logic Programming

# Learning as search

- **Structuring the state space:** Representing a partial order of hypotheses (e.g. rules) as a graph
  - nodes: concept descriptions (hypotheses/rules)
  - arcs defined by specialization/generalization operators : an arc from parent to child exists if-and-only-if parent is a proper most specific generalization of child
- **Specialization operators:** e.g., adding conditions:  
 $s(A=a_2 \ \& \ B=b_1) = \{A=a_2 \ \& \ B=b_1 \ \& \ D=d_1, A=a_2 \ \& \ B=b_1 \ \& \ D=d_2\}$
- **Generalization operators:** e.g., dropping conditions:  
 $g(A=a_2 \ \& \ B=b_1) = \{A=a_2, B=b_1\}$
- **Partial order of hypotheses defines a lattice (called a refinement graph)**

# Learn-one-rule as search - Structuring the hypothesis space: PlayTennis example

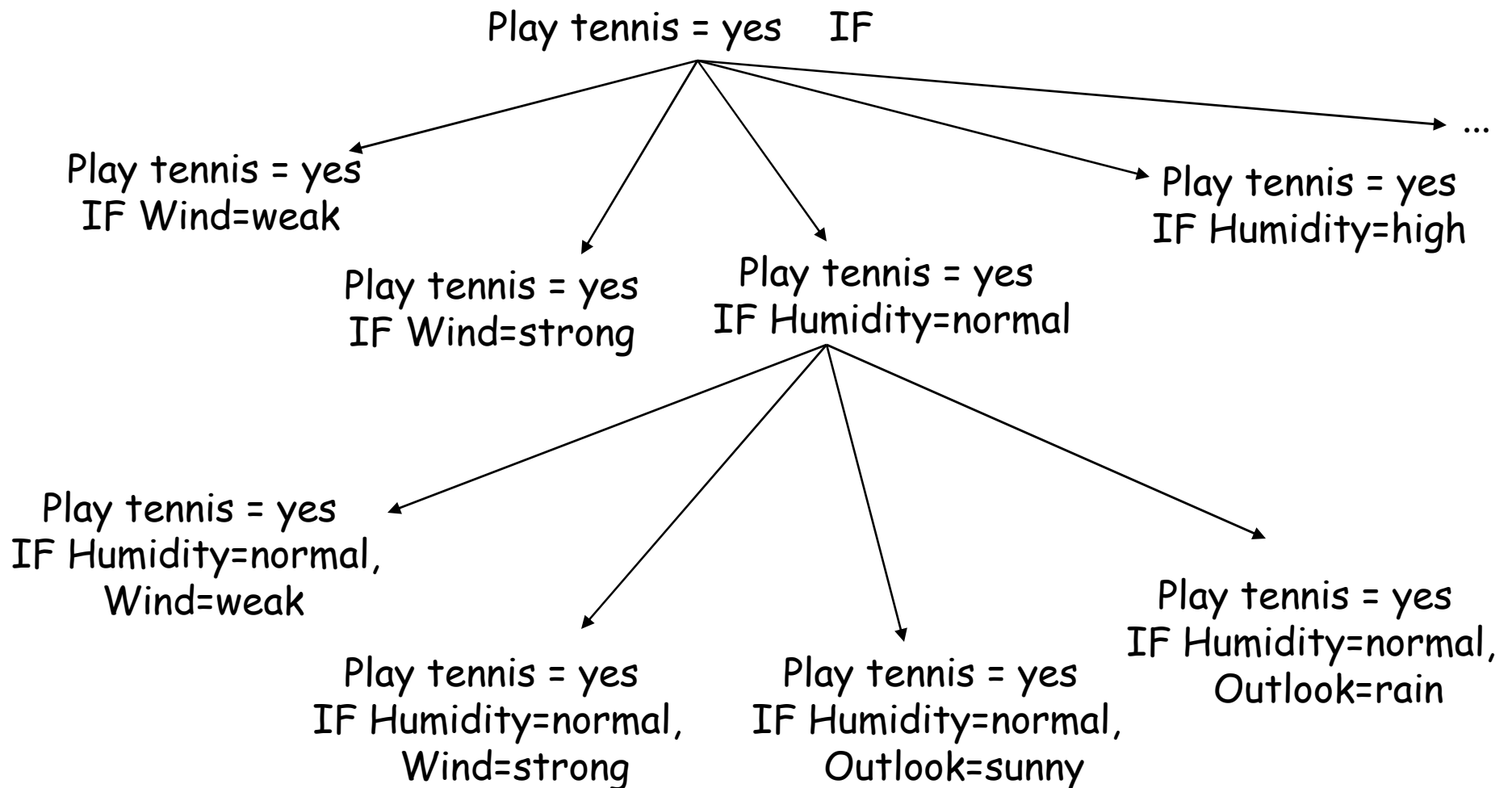

# Learn-one-rule as heuristic search: PlayTennis example

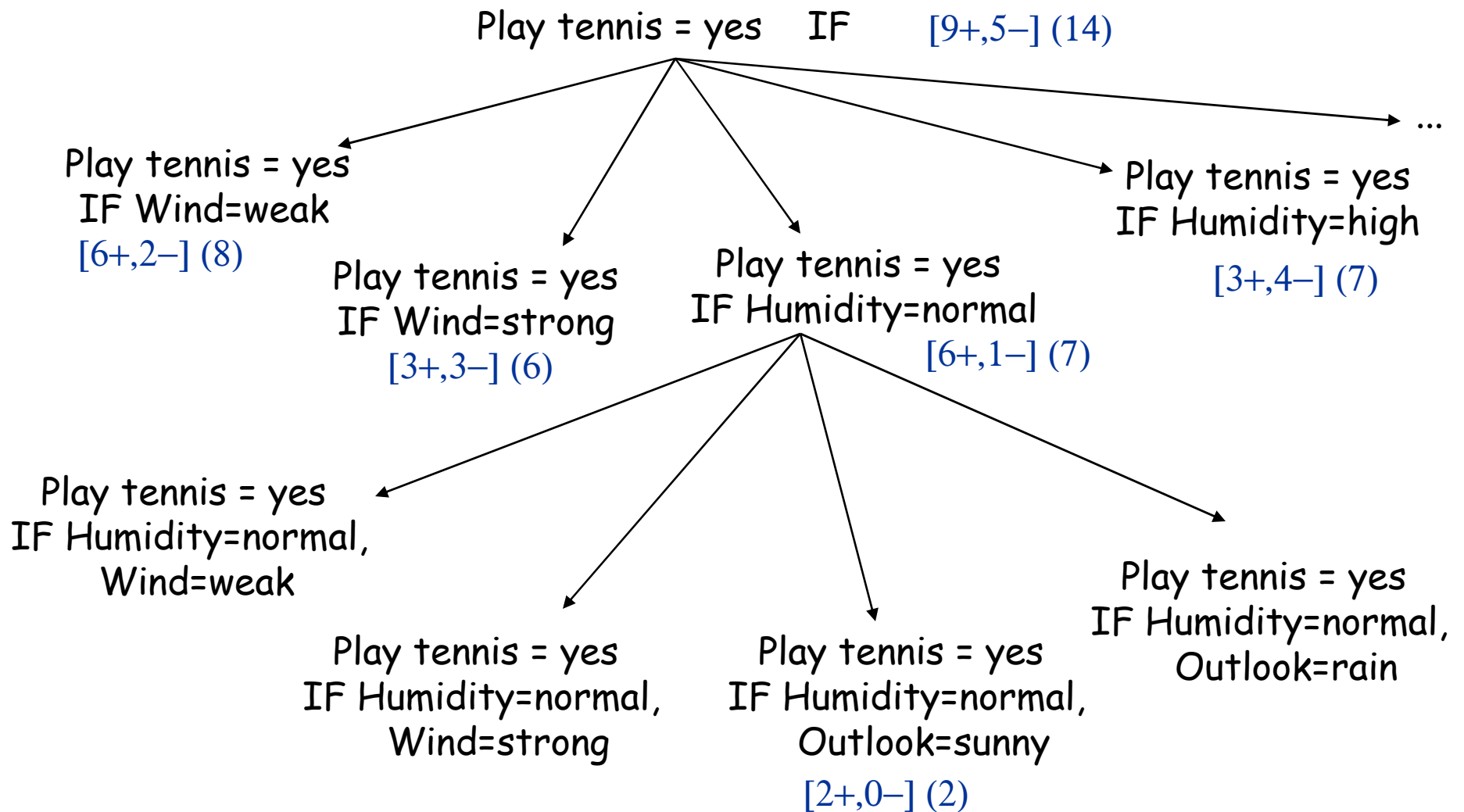

# Learning as search

## (Mitchell's version space model)

- Hypothesis language  $L_H$  defines the state space
- How to structure the hypothesis space  $L_H$ ?
- How to move from one hypothesis to another?
- The version space: region between S (maximally specific) and G (maximally general) complete and consistent concept descriptions

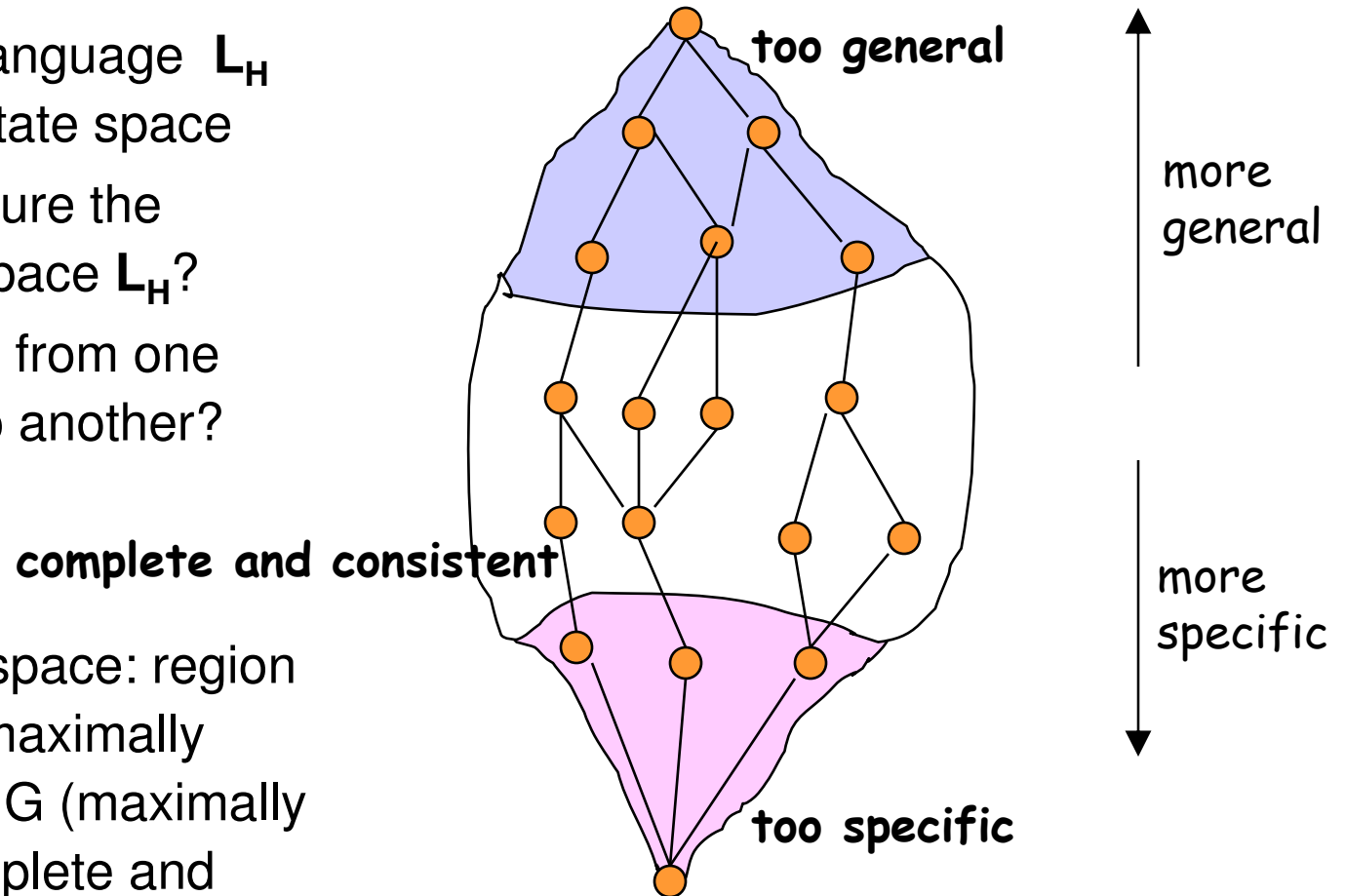

# Learning as search

- Search/move by applying generalization and specialization
- **Prune generalizations:**
  - if  $H$  covers example  $e$  then all generalizations of  $H$  will also cover  $e$  (prune using neg. ex.)
- **Prune specializations:**
  - if  $H$  does not cover example  $e$ , no specialization will cover  $e$  (prune using if  $H$  pos. ex.)

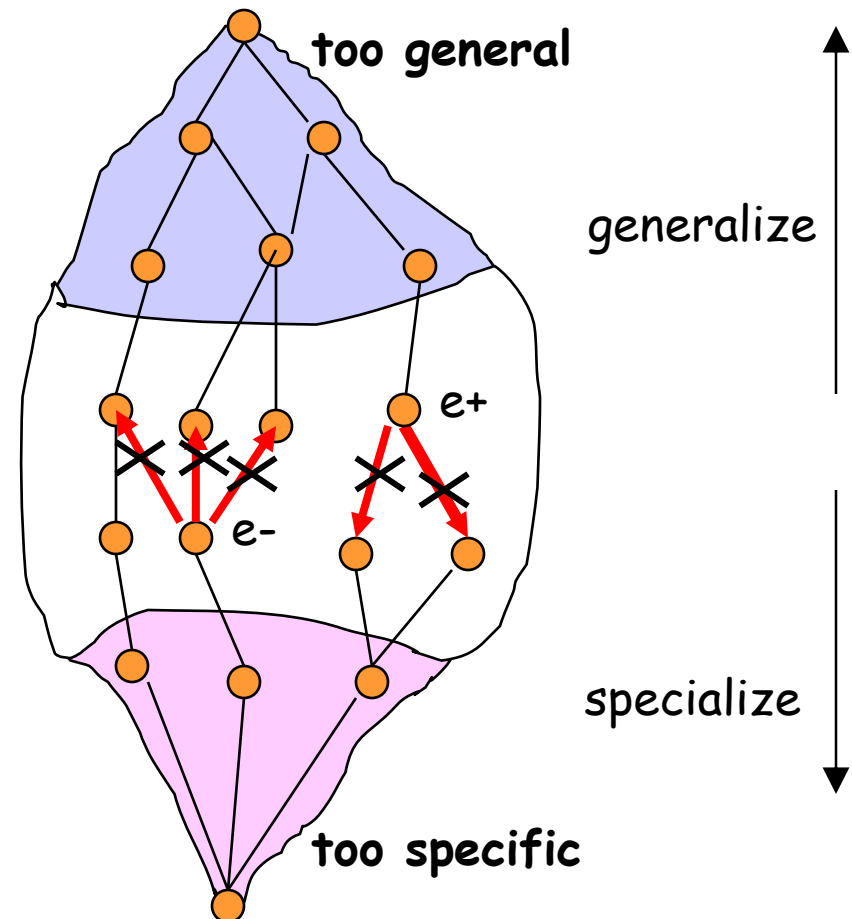

# Learning as search: Learner's ingredients

- structure of the search space (specialization and generalization operators)
- search strategy
  - depth-first
  - breath-first
  - heuristic search (best first, hill-climbing, beam search)
- search heuristics
  - measure of attribute 'informativity'
  - measure of 'expected classification accuracy' (relative frequency, Laplace estimate, m-estimate), ...
- stopping criteria (consistency, completeness, statistical significance, ...)

# Learn-one-rule: search heuristics

- Assume a two-class problem
- Two classes (+,-), learn rules for + class (Cl).
- Search for specializations R' of a rule  $R = Cl \leftarrow Cond$  from the RuleBase.
- Specialization R' of rule  $R = Cl \leftarrow Cond$   
has the form  $R' = Cl \leftarrow Cond \ \& \ Cond'$
- Heuristic search for rules: find the 'best' Cond' to be added to the current rule R, such that rule accuracy is improved, e.g., such that  $Acc(R') > Acc(R)$ 
  - where the expected **classification accuracy** can be estimated as  $A(R) = p(Cl|Cond)$



# Learn-one-rule – Search strategy: Greedy vs. beam search

- learn-one-rule by greedy general-to-specific search, at each step selecting the `best' descendant, no backtracking
  - e.g., the best descendant of the initial rule
    - PlayTennis = yes ←
    - is rule PlayTennis = yes ← Humidity=normal
- beam search: maintain a list of k best candidates at each step; descendants (specializations) of each of these k candidates are generated, and the resulting set is again reduced to k best candidates

# Part V:

## Relational Data Mining

- Learning as search
- What is RDM?
- Propositionalization techniques
- Inductive Logic Programming

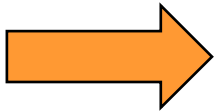

# Predictive relational DM

- Data stored in relational databases
- Single relation - propositional DM
  - example is a tuple of values of a fixed number of attributes (one attribute is a class)
  - example set is a table (simple field values)
- Multiple relations - relational DM (ILP)
  - example is a tuple or a set of tuples (logical fact or set of logical facts)
  - example set is a set of tables (simple or complex structured objects as field values)

# Data for propositional DM

## Sample single relation data table

ID	Name	First Name	Street	City	Zip	Sex	Social Status	In-come	Age	Club Status	Res-ponse
...	...	...	...	...	...	...	...	...	...	...	...
3478	Smith	John	38, Lake Dr	Sampton	34677	male	single	60-70k	32	member	no response
3479	Doe	Jane	45, Sea Ct	Invention	43666	female	married	80-90k	45	non-member	response
...	...	...	...	...	...	...	...	...	...	...	...

Basic customer table.

ID	Zip	Sex	Soc St	In come	Age	Cl ub	Re sp
...	...	...	...	...	...	...	...
3478	34677	m	si	60-70	32	me	nr
3479	43666	f	ma	80-90	45	nm	re
...	...	...	...	...	...	...	...

Customer table for analysis.

ID	Zip	Sex	Soc St	In come	Age	Cl ub	Re sp	Delivery Mode	Paymt Mode	Store Size	Store Type	Store Locatn
...	...	...	...	...	...	...	...	...	...	...	...	...
3478	34677	m	si	60-70	32	me	nr	regular	cash	small	franchise	city
3479	43666	f	ma	80-90	45	nm	re	express	credit	large	indep	rural
...	...	...	...	...	...	...	...	...	...	...	...	...

Customer table including order and store information.

# Multi-relational data made propositional

- Sample relation table

ID	Zip	Sex	SoSt	Income	Age	Club	Resp	Delivery Mode	Paymt Mode	Store Size	Store Type	Store Locatn
...	...	...	...	...	...	...	...	...	...	...	...	...
3478	34677	m	si	60-70	32	me	nr	regular	cash	small	franchise	city
3478	34677	m	si	60-70	32	me	nr	express	check	small	franchise	city
3478	34677	m	si	60-70	32	me	nr	regular	check	large	indep	rural
3479	43666	f	ma	80-90	45	nm	re	express	credit	large	indep	rural
3479	43666	f	ma	80-90	45	nm	re	regular	credit	small	franchise	city
...	...	...	...	...	...	...	...	...	...	...	...	...

Customer table with multiple orders.

- Making data using summary

ID	Zip	Sex	SoSt	Income	Age	Club	Resp	No. of Orders	No. of Stores
...	...	...	...	...	...	...	...	...	...
3478	34677	m	si	60-70	32	me	nr	3	2
3479	43666	f	ma	80-90	45	nm	re	2	2
...	...	...	...	...	...	...	...	...	...

Customer table using summary attributes.

# Relational Data Mining (ILP)

- Learning from multiple tables
- Complex relational problems:
  - **temporal data:** time series in medicine, traffic control, ...
  - **structured data:** representation of molecules and their properties in protein engineering, biochemistry, ...

customer							
ID	Zip	Sex	SoSt	Income	Age	Club	Resp
...	...	...	...	...	...	...	...
3478	34677	m	si	60-70	32	me	nr
3479	43666	f	ma	80-90	45	nm	re
...	...	...	...	...	...	...	...

order				
Customer ID	Order ID	Store ID	Delivery Mode	Paymt Mode
...	...	...	...	...
3478	2140267	12	regular	cash
3478	3446778	12	express	check
3478	4728386	17	regular	check
3479	3233444	17	express	credit
3479	3475886	12	regular	credit
...	...	...	...	...

store			
Store ID	Size	Type	Location
...	...	...	...
12	small	franchise	city
17	large	indep	rural
...	...	...	...

Relational representation of customers, orders and stores.

# Basic Relational Data Mining tasks

**Predictive RDM**

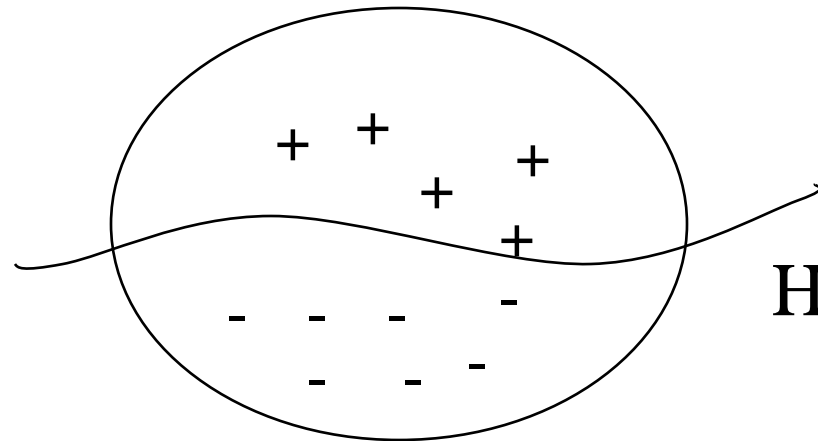

**Descriptive RDM**

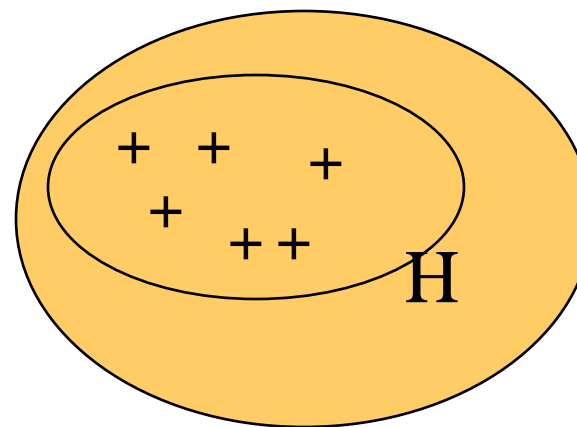

# Predictive ILP

- **Given:**
  - A set of observations
    - positive examples  $E^+$
    - negative examples  $E^-$
  - background knowledge  $B$
  - hypothesis language  $L_H$
  - **covers** relation
- **Find:**  
A hypothesis  $H \in L_H$ , such that (given  $B$ )  $H$  covers all positive and no negative examples
- In logic, **find**  $H$  such that
  - $\forall e \in E^+ : B \wedge H \models e$  ( $H$  is complete)
  - $\forall e \in E^- : B \wedge H \not\models e$  ( $H$  is consistent)
- In ILP,  $E$  are ground facts,  $B$  and  $H$  are (sets of) definite clauses

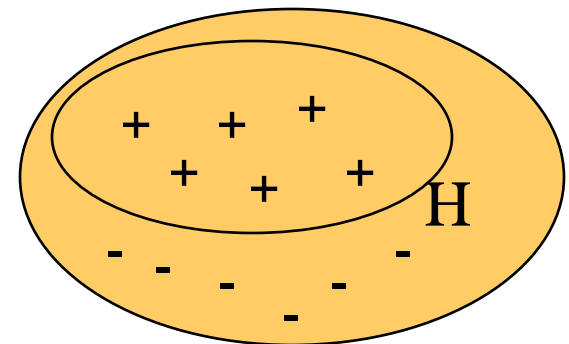



# Predictive ILP

- **Given:**

- A set of observations
  - positive examples  $E^+$
  - negative examples  $E^-$
- background knowledge  $B$
- hypothesis language  $L_H$
- covers relation
- **quality criterion**

- **Find:**

A hypothesis  $H \in L_H$ , such that (given  $B$ )  $H$  is optimal w.r.t. some quality criterion, e.g., max. predictive accuracy  $A(H)$

(**instead of** finding a hypothesis  $H \in L_H$ , such that (given  $B$ )  $H$  covers **all** positive and **no** negative examples)

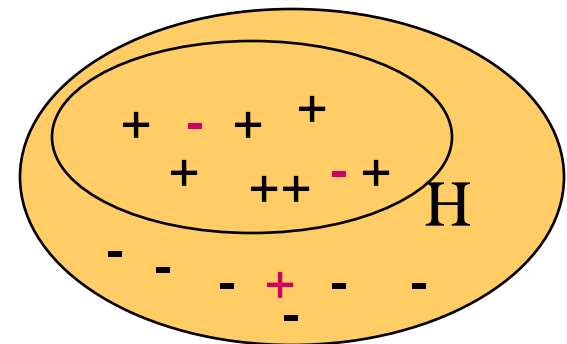

# Descriptive ILP

- **Given:**
  - A set of observations  
(positive examples  $E^+$ )
  - background knowledge  $B$
  - hypothesis language  $L_H$
  - covers relation
- **Find:**  
Maximally specific hypothesis  $H \in L_H$ , such that (given  $B$ )  $H$  covers all positive examples
- In logic, **find**  $H$  such that  $\forall c \in H, c$  is true in some preferred model of  $B \cup E$  (e.g., least Herbrand model  $M(B \cup E)$ )
- In ILP,  $E$  are ground facts,  $B$  are (sets of) general clauses

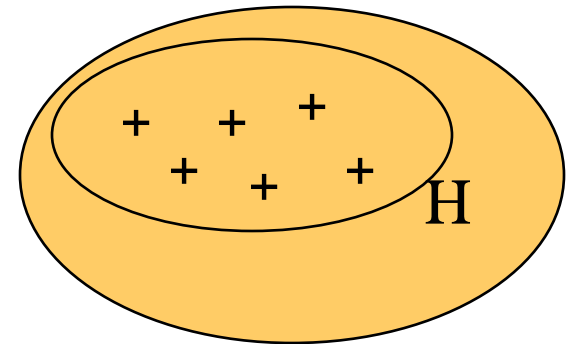

# Sample problem

## Knowledge discovery

$E^+ = \{ \text{daughter}(\text{mary}, \text{ann}), \text{daughter}(\text{eve}, \text{tom}) \}$

$E^- = \{ \text{daughter}(\text{tom}, \text{ann}), \text{daughter}(\text{eve}, \text{ann}) \}$

$B = \{ \text{mother}(\text{ann}, \text{mary}), \text{mother}(\text{ann}, \text{tom}),$   
 $\text{father}(\text{tom}, \text{eve}), \text{father}(\text{tom}, \text{ian}), \text{female}(\text{ann}),$   
 $\text{female}(\text{mary}), \text{female}(\text{eve}), \text{male}(\text{pat}), \text{male}(\text{tom}),$   
 $\text{parent}(X, Y) \leftarrow \text{mother}(X, Y), \text{parent}(X, Y) \leftarrow$   
 $\text{father}(X, Y) \}$

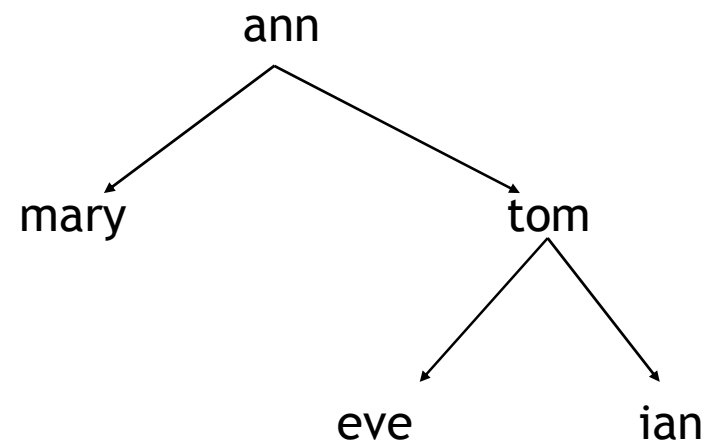

# Sample problem

## Knowledge discovery

- $E^+ = \{ \text{daughter}(\text{mary}, \text{ann}), \text{daughter}(\text{eve}, \text{tom}) \}$   
 $E^- = \{ \text{daughter}(\text{tom}, \text{ann}), \text{daughter}(\text{eve}, \text{ann}) \}$
- $B = \{ \text{mother}(\text{ann}, \text{mary}), \text{mother}(\text{ann}, \text{tom}), \text{father}(\text{tom}, \text{eve}), \text{father}(\text{tom}, \text{ian}), \text{female}(\text{ann}), \text{female}(\text{mary}), \text{female}(\text{eve}), \text{male}(\text{pat}), \text{male}(\text{tom}), \text{parent}(X, Y) \leftarrow \text{mother}(X, Y), \text{parent}(X, Y) \leftarrow \text{father}(X, Y) \}$

- **Predictive ILP** - Induce a definite clause

$\text{daughter}(X, Y) \leftarrow \text{female}(X), \text{parent}(Y, X).$

or a set of definite clauses

$\text{daughter}(X, Y) \leftarrow \text{female}(X), \text{mother}(Y, X).$

$\text{daughter}(X, Y) \leftarrow \text{female}(X), \text{father}(Y, X).$

- **Descriptive ILP** - Induce a set of (general) clauses

$\leftarrow \text{daughter}(X, Y), \text{mother}(X, Y).$

$\text{female}(X) \leftarrow \text{daughter}(X, Y).$

$\text{mother}(X, Y); \text{father}(X, Y) \leftarrow \text{parent}(X, Y).$

# Sample problem

## Logic programming

$$E^+ = \{\text{sort}([2, 1, 3], [1, 2, 3])\}$$

$$E^- = \{\text{sort}([2, 1], [1]), \text{sort}([3, 1, 2], [2, 1, 3])\}$$

$B$ : definitions of permutation/2 and sorted/1

- **Predictive ILP**

$$\text{sort}(X, Y) \leftarrow \text{permutation}(X, Y), \text{sorted}(Y).$$

- **Descriptive ILP**

$$\text{sorted}(Y) \leftarrow \text{sort}(X, Y).$$

$$\text{permutation}(X, Y) \leftarrow \text{sort}(X, Y)$$

$$\text{sorted}(X) \leftarrow \text{sort}(X, X)$$

# Sample problem: East-West trains

## 1. TRAINS GOING EAST

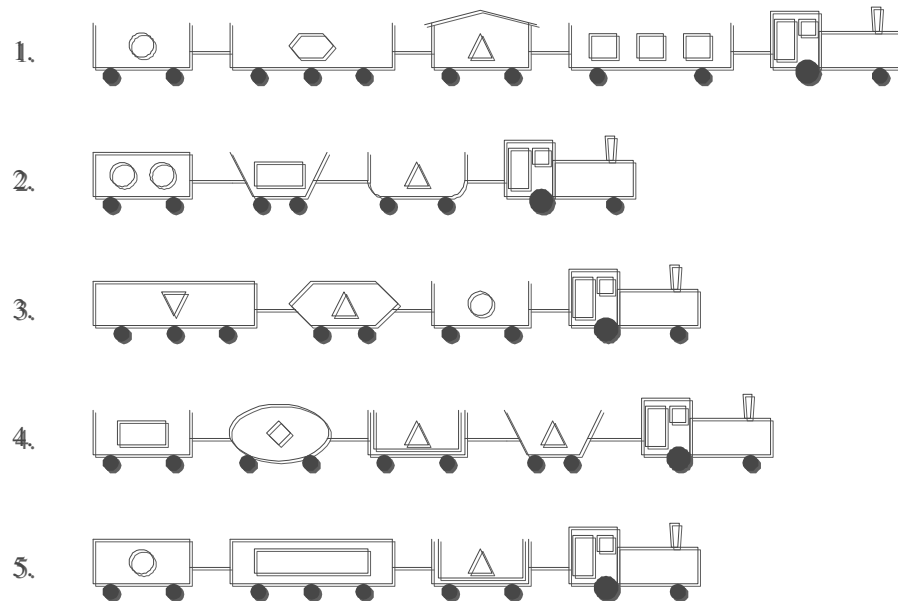

## 2. TRAINS GOING WEST

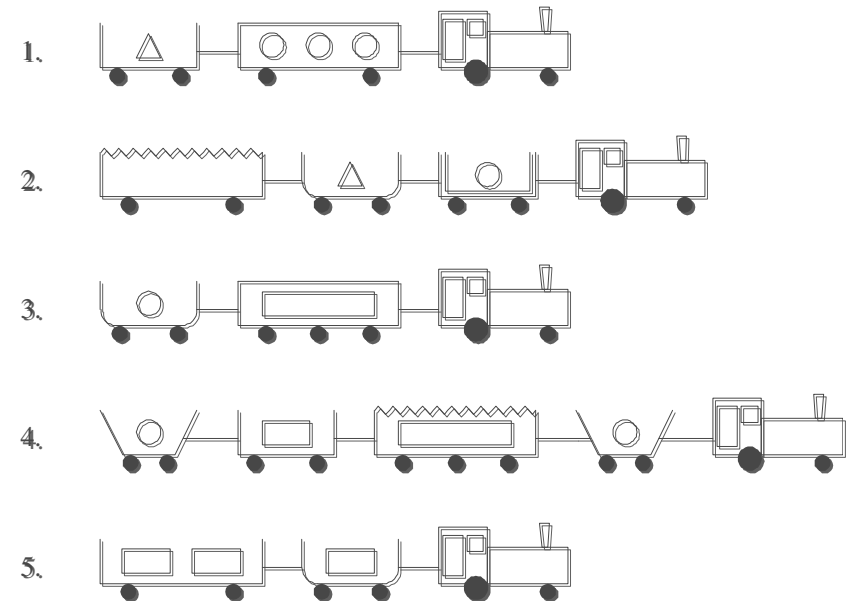

# RDM knowledge representation (database) <sup>319</sup>

**LOAD\_TABLE**

<u>LOAD</u>	<u>CAR</u>	<u>OBJECT</u>	<u>NUMBER</u>
l1	c1	circle	1
l2	c2	hexagon	1
l3	c3	triangle	1
l4	c4	rectangle	3
...	...	...	...

**TRAIN\_TABLE**

<u>TRAIN</u>	<u>EASTBOUND</u>
t1	TRUE
t2	TRUE
...	...
t6	FALSE
...	...

**CAR\_TABLE**

<u>CAR</u>	<u>TRAIN</u>	<u>SHAPE</u>	<u>LENGTH</u>	<u>ROOF</u>	<u>WHEELS</u>
c1	t1	rectangle	short	none	2
c2	t1	rectangle	long	none	3
c3	t1	rectangle	short	peaked	2
c4	t1	rectangle	long	none	2
...	...	...	...	...	...



# ER diagram for East-West trains

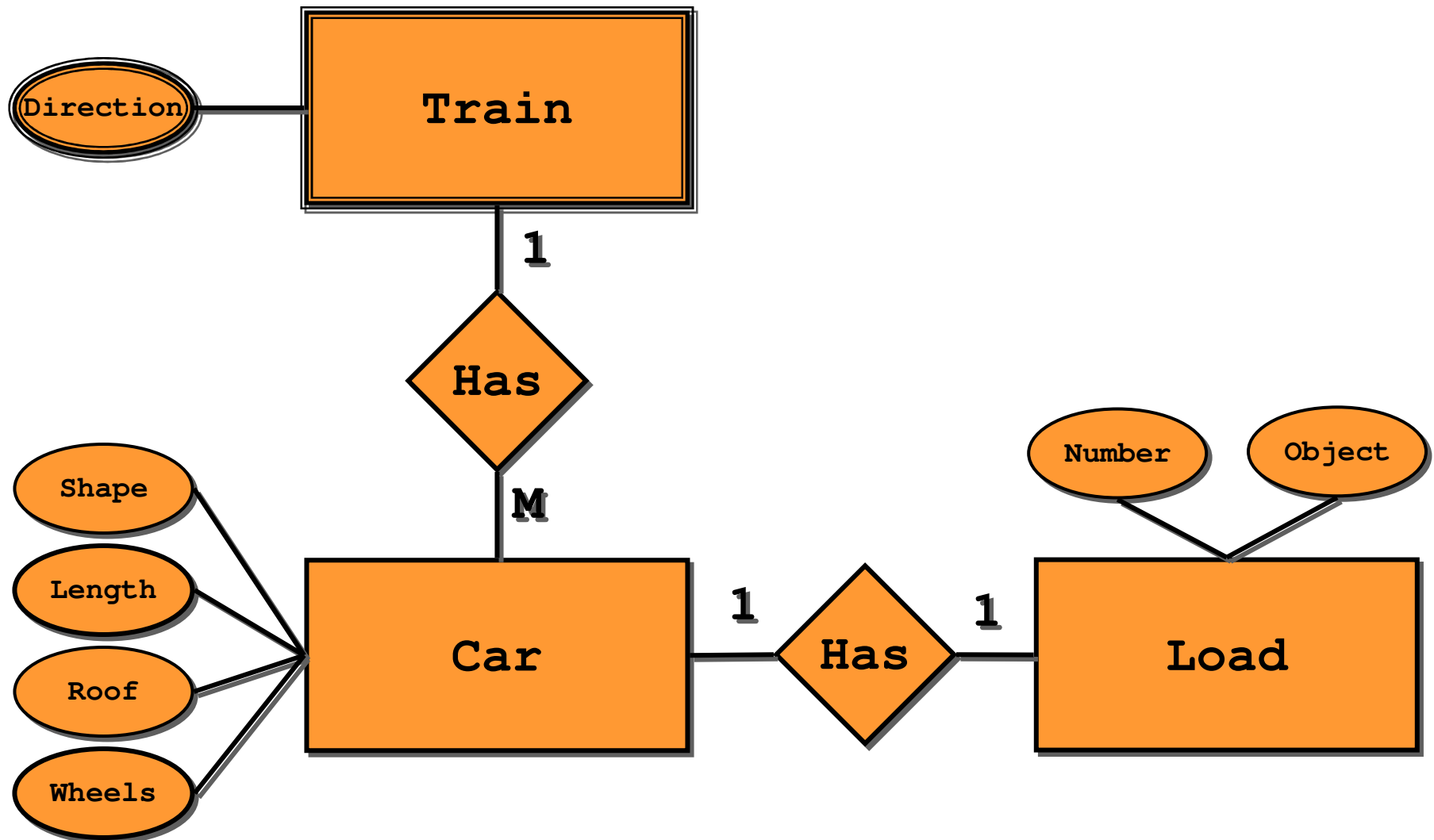



# ILP representation: Datalog ground facts

- Example:  
eastbound(t1).



- Background theory:

car(t1,c1).	car(t1,c2).	car(t1,c3).	car(t1,c4).
rectangle(c1).	rectangle(c2).	rectangle(c3).	rectangle(c4).
short(c1).	long(c2).	short(c3).	long(c4).
none(c1).	none(c2).	peaked(c3).	none(c4).
two_wheels(c1).	three_wheels(c2).	two_wheels(c3).	two_wheels(c4).
load(c1,l1).	load(c2,l2).	load(c3,l3).	load(c4,l4).
circle(l1).	hexagon(l2).	triangle(l3).	rectangle(l4).
one_load(l1).	one_load(l2).	one_load(l3).	three_loads(l4).

- Hypothesis (predictive ILP):  
eastbound(T) :- car(T,C),short(C),not none(C).

# ILP representation: Datalog ground clauses



- Example:  
eastbound(t1):-  
 car(t1,c1),rectangle(c1),short(c1),none(c1),two\_wheels(c1),  
   load(c1,l1),circle(l1),one\_load(l1),  
 car(t1,c2),rectangle(c2),long(c2),none(c2),three\_wheels(c2),  
   load(c2,l2),hexagon(l2),one\_load(l2),  
 car(t1,c3),rectangle(c3),short(c3),peaked(c3),two\_wheels(c3),  
   load(c3,l3),triangle(l3),one\_load(l3),  
 car(t1,c4),rectangle(c4),long(c4),none(c4),two\_wheels(c4),  
   load(c4,l4),rectangle(l4),three\_load(l4).
- Background theory: empty
- Hypothesis:  
eastbound(T):-car(T,C),short(C),not none(C).

# ILP representation: Prolog terms



- Example:
 

```
eastbound([c(rectangle,short,none,2,l(circle,1)),
            c(rectangle,long,none,3,l(hexagon,1)),
            c(rectangle,short,peaked,2,l(triangle,1)),
            c(rectangle,long,none,2,l(rectangle,3))]).
```
- Background theory: member/2, arg/3
- Hypothesis:
 

```
eastbound(T):-member(C,T),arg(2,C,short), not arg(3,C,none).
```

# First-order representations

- **Propositional** representations:
  - datacase is *fixed-size vector of values*
  - features are those given in the dataset
- **First-order** representations:
  - datacase is *flexible-size, structured object*
    - sequence, set, graph
    - hierarchical: e.g. set of sequences
  - features need to be **selected** from potentially infinite set

# Complexity of RDM problems

- Simplest case: single table with primary key
  - example corresponds to tuple of constants
  - *attribute-value* or *propositional* learning
- Next: single table without primary key
  - example corresponds to set of tuples of constants
  - *multiple-instance* problem
- Complexity resides in many-to-one foreign keys
  - lists, sets, multisets
  - *non-determinate* variables

# Part V: Relational Data Mining

- Learning as search
- What is RDM?
- Propositionalization techniques
- Inductive Logic Programming

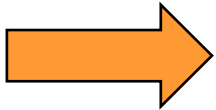

# Rule learning: The standard view

- **Hypothesis construction**: find a set of  $n$  rules
  - usually simplified by  $n$  separate rule constructions
    - exception: HYPER
- **Rule construction**: find a pair (Head, Body)
  - e.g. select head (class) and construct body by searching the VersionSpace
    - exceptions: CN2, APRIORI
- **Body construction**: find a set of  $m$  literals
  - usually simplified by adding one literal at a time
    - problem (ILP): literals introducing new variables

# Rule learning revisited

- **Hypothesis construction**: find a set of  $n$  rules
- **Rule construction**: find a pair (Head, Body)
- **Body construction**: find a set of  $m$  features
  - Features can be either defined by background knowledge or constructed through constructive induction
  - In propositional learning features may increase expressiveness through negation
  - Every ILP system does constructive induction
- **Feature construction**: find a set of  $k$  literals
  - finding interesting features is discovery task rather than classification task e.g. interesting subgroups, frequent itemsets
  - excellent results achieved also by feature construction through predictive propositional learning and ILP (Srinivasan)



# First-order feature construction

- All the expressiveness of ILP is in the features
- Given a way to construct (or choose) first-order features, body construction in ILP becomes propositional
  - idea: learn non-determinate clauses with LINUS by saturating background knowledge (performing systematic feature construction in a given language bias)

# Standard LINUS

- **Example: learning family relationships**

Training examples		Background knowledge	
daughter(sue,eve). (+)		parent(eve,sue).	female(ann).
daughter(ann,pat). (+)		parent(ann,tom).	female(sue).
daughter(tom,ann). (-)		parent(pat,ann).	female(eve).
daughter(eve,ann). (-)		parent(tom,sue).	

- **Transformation to propositional form:**

Class	Variables		Propositional features						
	X	Y	f(X)	f(Y)	p(X,X)	p(X,Y)	p(Y,X)	p(Y,Y)	X=Y
⊕	sue	eve	true	true	false	false	true	false	false
⊕	ann	pat	true	false	false	false	true	false	false
⊖	tom	ann	false	true	false	false	true	false	false
⊖	eve	ann	true	true	false	false	false	false	false

- **Result of propositional rule learning:**

Class = ⊕ if  $(\text{female}(X) = \text{true}) \wedge (\text{parent}(Y,X) = \text{true})$

- **Transformation to program clause form:**

daughter(X,Y) ← female(X),parent(Y,X)

# Representation issues (1)

- In the database and Datalog ground fact representations individual examples are not easily separable
- Term and Datalog ground clause representations enable the separation of individuals
- Term representation collects all information about an individual in one structured term

# Representation issues (2)

- Term representation provides strong language bias
- Term representation can be flattened to be described by ground facts, using
  - structural predicates (e.g. `car(t1,c1)`, `load(c1,l1)`) to introduce substructures
  - utility predicates, to define properties of individuals (e.g. `long(t1)`) or their parts (e.g., `long(c1)`, `circle(l1)`).
- This observation can be used as a language bias to construct new features

# Declarative bias for first-order feature construction

- In ILP, features involve interactions of local variables
- Features should define properties of individuals (e.g. trains, molecules) or their parts (e.g., cars, atoms)
- Feature construction in LINUS, using the following language bias:
  - one free global variable (denoting an individual, e.g. train)
  - one or more structural predicates: (e.g., `has_car(T,C)`), each introducing a new existential local variable (e.g. car, atom), using either the global variable (train, molecule) or a local variable introduced by other structural predicates (car, load)
  - one or more utility predicates defining properties of individuals or their parts: no new variables, just using variables
  - all variables should be used
  - parameter: max. number of predicates forming a feature

# Sample first-order features

- The following rule has two features ‘has a short car’ and ‘has a closed car’:

eastbound(T):-hasCar(T,C1),clength(C1,short),  
hasCar(T,C2),not croof(C2,none).

- The following rule has one feature ‘has a short closed car’:

eastbound(T):-hasCar(T,C),clength(C,short),  
not croof(C,none).

- Equivalent representation:

eastbound(T):-hasShortCar(T),hasClosedCar(T).

hasShortCar(T):-hasCar(T,C),clength(C,short).

hasClosedCar(T):-hasCar(T,C),not croof(C,none).

# Propositionalization in a nutshell



## Propositionalization task

**Transform** a multi-relational  
(**multiple-table**)  
representation to a  
propositional representation  
(**single table**)

Proposed in ILP systems  
LINUS (1991), IBC (1999), ...

LOAD	CAR	OBJECT	NUMBER
l1	c1	circle	1
l2	c2	hexagon	1
l3	c3	triangle	1
l4	c4	rectangle	3
...	...	...	...

TRAIN_TABLE	
TRAIN	EASTBOUND
t1	TRUE
t2	TRUE
...	...
t6	FAL SE
...	...

CAR	TRAIN	SHAPE	LENGTH	ROOF	WHEELS
c1	t1	rectangle	short	none	2
c2	t1	rectangle	long	none	3
c3	t1	rectangle	short	peaked	2
c4	t1	rectangle	long	none	2
...	...	...	...	...	...

## PROPOSITIONAL TRAIN\_TABLE

<u>train(T)</u>	f1(T)	f2(T)	f3(T)	f4(T)	f5(T)
t1	t	t	f	t	t
t2	t	t	t	t	t
t3	f	f	t	f	f
t4	t	f	t	f	f
...	...	...	...	...	...

# Propositionalization in a nutshell

**Main propositionalization step:  
first-order feature construction**

$f_1(T) :- \text{hasCar}(T, C), \text{clength}(C, \text{short}).$

$f_2(T) :- \text{hasCar}(T, C), \text{hasLoad}(C, L),$   
 $\quad \text{loadShape}(L, \text{circle})$

$f_3(T) :- \dots$

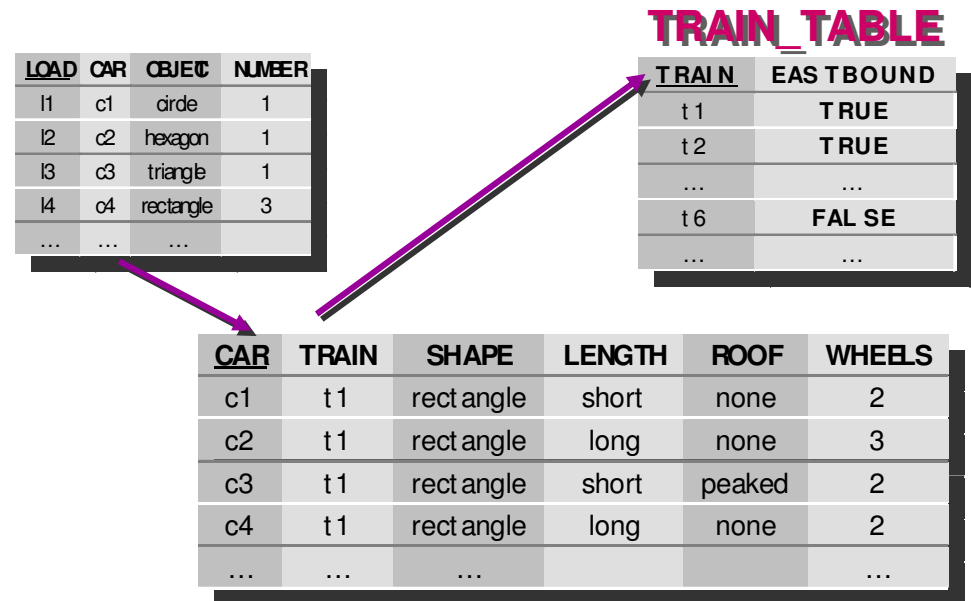

**Propositional learning:**

$t(T) \leftarrow f_1(T), f_4(T)$

**Relational interpretation:**

$\text{eastbound}(T) \leftarrow$

$\text{hasShortCar}(T), \text{hasClosedCar}(T).$

**PROPOSITIONAL TRAIN\_TABLE**

train(T)	f1(T)	f2(T)	f3(T)	f4(T)	f5(T)
t1	t	t	f	t	t
t2	t	t	t	t	t
t3	f	f	t	f	f
t4	t	f	t	f	f
...	...	...	...	...	...



# LINUS revisited

- Standard LINUS:
  - transforming an ILP problem to a propositional problem
  - apply background knowledge predicates
- Revisited LINUS:
  - Systematic first-order feature construction in a given language bias
- Too many features?
  - use a relevancy filter (Gamberger and Lavrac)

# LINUS revisited:

## Example: East-West trains

**Rules induced by CN2, using 190 first-order features with up to two utility predicates:**

eastbound(T):-

hasCarHasLoadSingleTriangle(T),  
not hasCarLongJagged(T),  
not hasCarLongHasLoadCircle(T).

westbound(T):-

not hasCarEllipse(T),  
not hasCarShortFlat(T),  
not hasCarPeakedTwo(T).

**Meaning:**

eastbound(T):-

hasCar(T,C1),hasLoad(C1,L1),lshape(L1,tria),lnumber(L1,1),  
not (hasCar(T,C2),clength(C2,long),croof(C2,jagged)),  
not (hasCar(T,C3),hasLoad(C3,L3),clength(C3,long),lshape(L3,circ)).

westbound(T):-

not (hasCar(T,C1),cshape(C1,ellipse)),  
not (hasCar(T,C2),clength(C2,short),croof(C2,flat)),  
not (hasCar(T,C3),croof(C3,peak),cwheels(C3,2)).

# Part V:

## Relational Data Mining

- Learning as search
- What is RDM?
- Propositionalization techniques

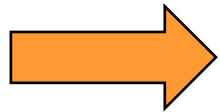

Inductive Logic Programming

# ILP as search of program clauses

- An ILP learner can be described by
  - the **structure of the space of clauses**
    - based on the generality relation
    - Let C and D be two clauses.  
C is more general than D ( $C \models D$ ) iff  

$$\text{covers}(D) \subseteq \text{covers}(C)$$
    - Example:  $p(X,Y) \leftarrow r(Y,X)$  is more general than  

$$p(X,Y) \leftarrow r(Y,X), q(X)$$
  - its **search strategy**
    - uninformed search (depth-first, breadth-first, iterative deepening)
    - heuristic search (best-first, hill-climbing, beam search)
  - its **heuristics**
    - for directing search
    - for stopping search (quality criterion)

# ILP as search of program clauses

- **Semantic generality**

Hypothesis  $H_1$  is semantically more general than  $H_2$  w.r.t. background theory  $B$  if and only if  $B \cup H_1 \models H_2$

- **Syntactic generality or  $\theta$ -subsumption**

(most popular in ILP)

- Clause  $c_1$   $\theta$ -subsumes  $c_2$  ( $c_1 \geq_{\theta} c_2$ )

if and only if  $\exists \theta: c_1 \theta \subseteq c_2$

- Hypothesis  $H_1 \geq_{\theta} H_2$

if and only if  $\forall c_2 \in H_2$  exists  $c_1 \in H_1$  such that  $c_1 \geq_{\theta} c_2$

- **Example**

$c_1 = \text{daughter}(X,Y) \leftarrow \text{parent}(Y,X)$

$c_2 = \text{daughter}(\text{mary},\text{ann}) \leftarrow \text{female}(\text{mary}),$   
 $\text{parent}(\text{ann},\text{mary}),$   
 $\text{parent}(\text{ann},\text{tom}).$

$c_1$   $\theta$ -subsumes  $c_2$  under  $\theta = \{X/\text{mary}, Y/\text{ann}\}$

# The role of subsumption in ILP

- Generality ordering for hypotheses
- Pruning of the search space:
  - generalization
    - if C covers a neg. example then its generalizations need not be considered
  - specialization
    - if C doesn't cover a pos. example then its specializations need not be considered
- Top-down search of refinement graphs
- Bottom-up search of the hypo. space by
  - building least general generalizations, and
  - inverting resolutions

# Structuring the hypothesis space

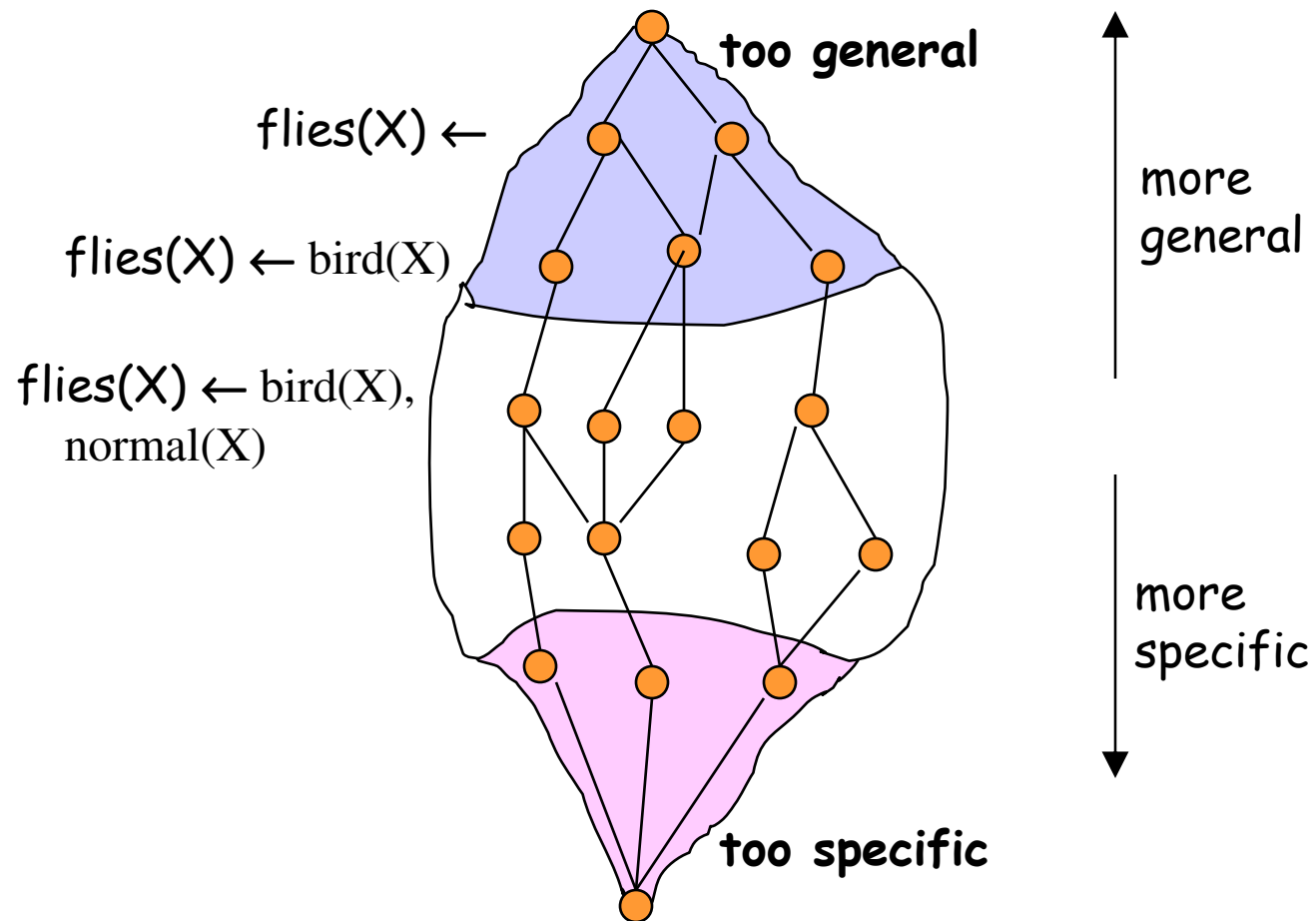

# Two strategies for learning

- General-to-specific
  - if  $\Theta$ -subsumption is used then refinement operators
- Specific-to-general search
  - if  $\Theta$ -subsumption is used then lgg-operator or generalization operator



# ILP as search of program clauses

- Two strategies for learning
  - Top-down search of refinement graphs
  - Bottom-up search
    - building least general generalizations
    - inverting resolution (CIGOL)
    - inverting entailment (PROGOL)

More general  
(induction)

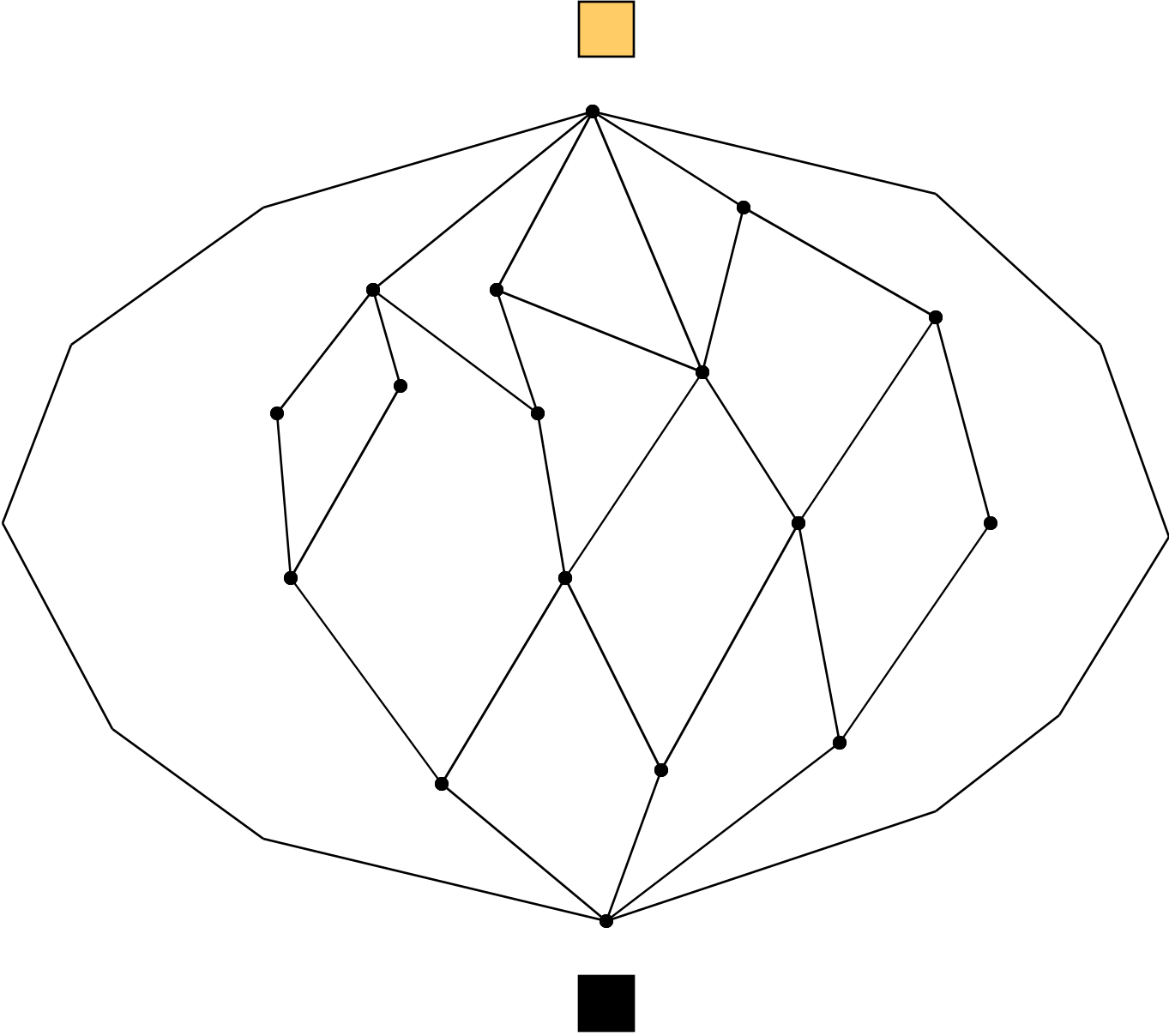
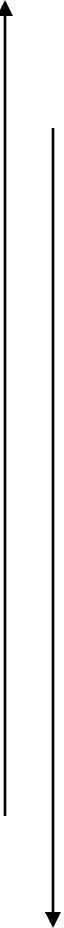

More  
specific

# Generality ordering of clauses

Training examples		Background knowledge	
daughter(mary,ann).	$\oplus$	parent(ann,mary).	female(ann.).
daughter(eve,tom).	$\oplus$	parent(ann,tom).	female(mary).
daughter(tom,ann).	$\ominus$	parent(tom,eve).	female(eve).
daughter(eve,ann).	$\ominus$	parent(tom,ian).	

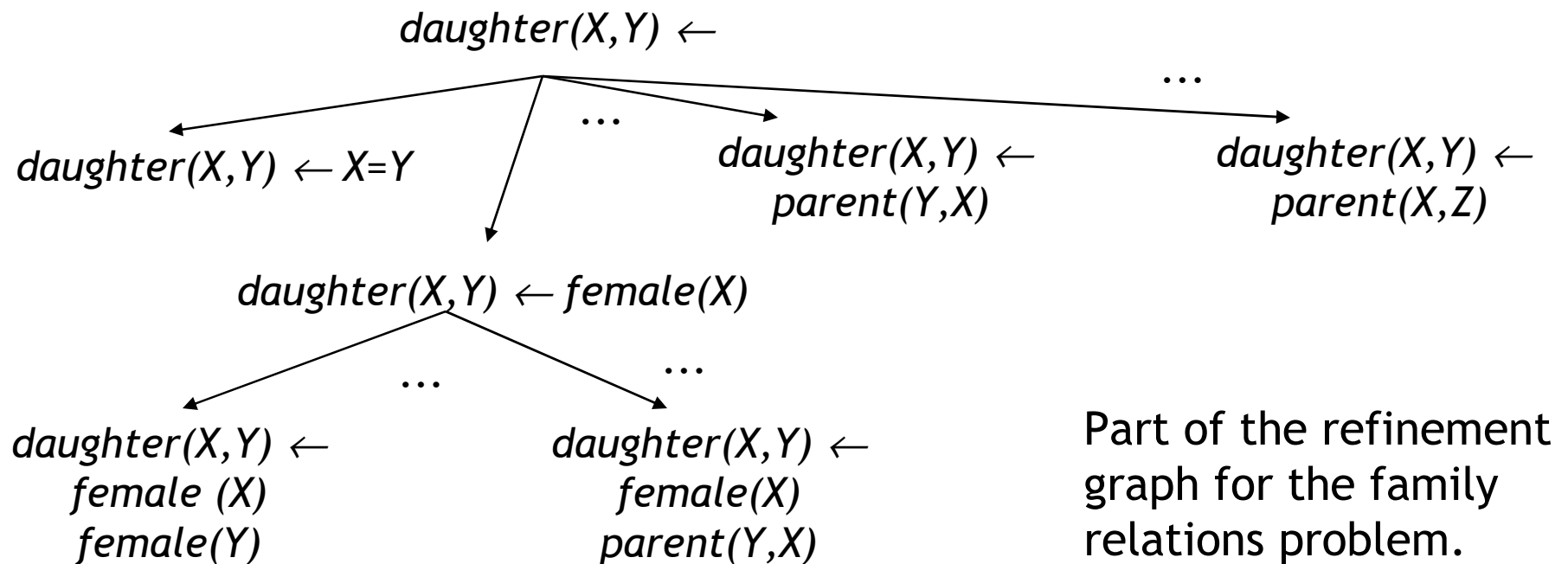

# Greedy search of the best clause

Training examples		Background knowledge	
daughter(mary,ann).	⊕	parent(ann,mary).	female(ann.).
daughter(eve,tom).	⊕	parent(ann,tom).	female(mary).
daughter(tom,ann).	⊖	parent(tom,eve).	female(eve).
daughter(eve,ann).	⊖	parent(tom,ian).	

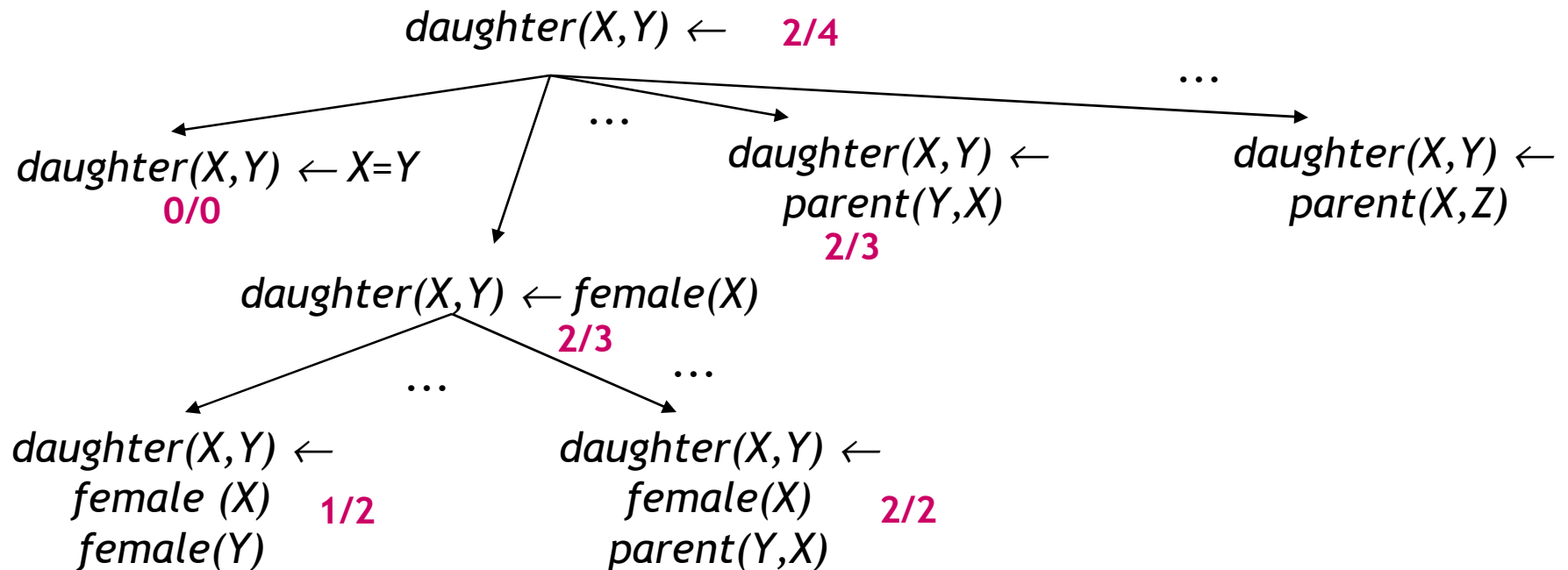

# FOIL

- Language: function-free normal programs  
recursion, negation, new variables in the body, no  
functors, no constants (original)
- Algorithm: covering
- Search heuristics: weighted info gain
- Search strategy: hill climbing
- Stopping criterion: encoding length restriction
- Search space reduction: types, in/out modes  
determinate literals
- Ground background knowledge, extensional  
coverage
- Implemented in C

# Part V: Summary

- RDM extends DM by allowing multiple tables describing structured data
- Complexity of representation and therefore of learning is determined by one-to-many links
- Many RDM problems are individual-centred and therefore allow strong declarative bias